

ASSEMBLY INSTRUCTION

CORNER SOFA SET

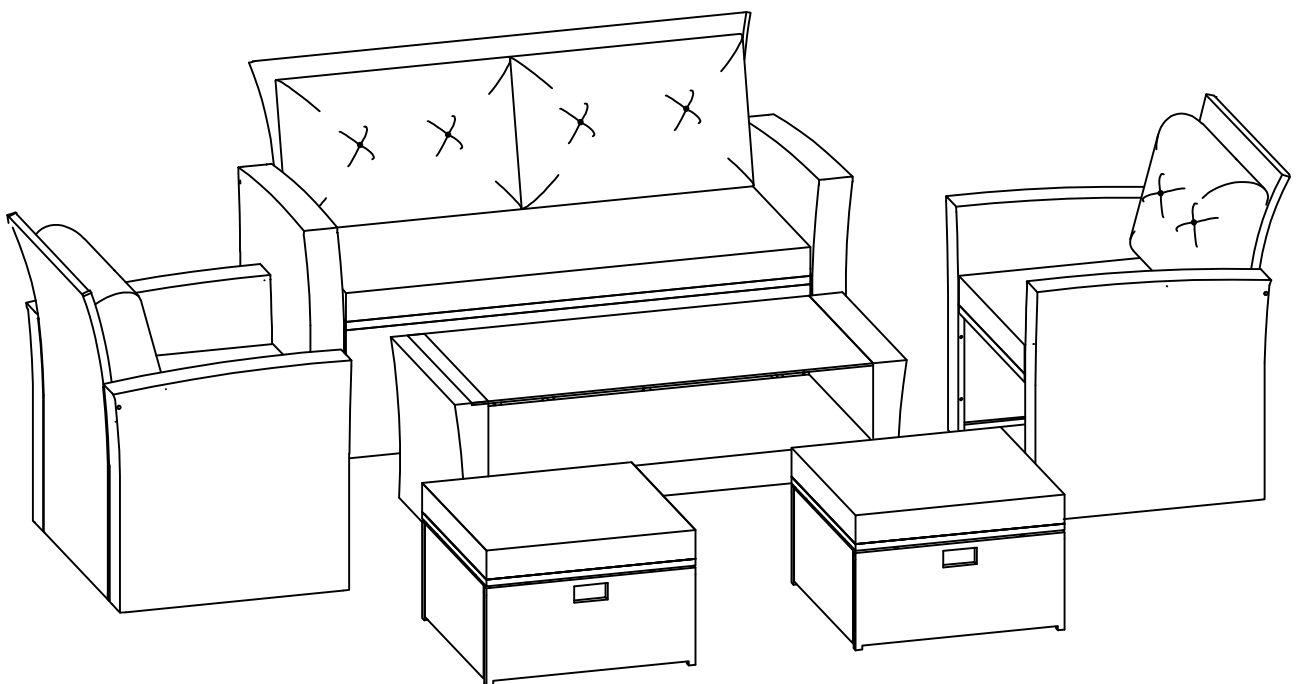

WF299720, WF299721

X1

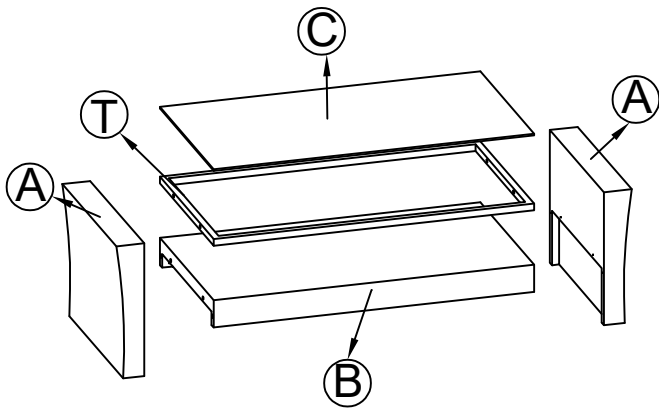

X2

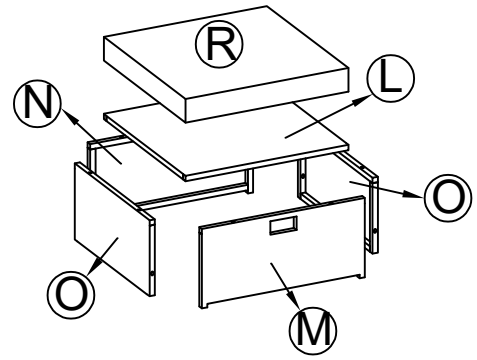

X2

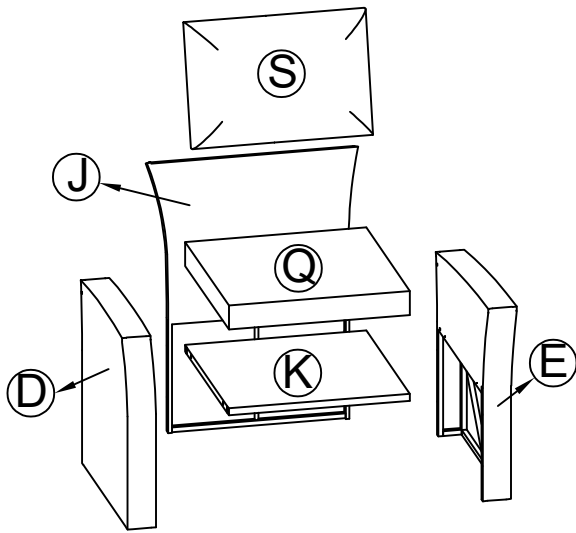

X1

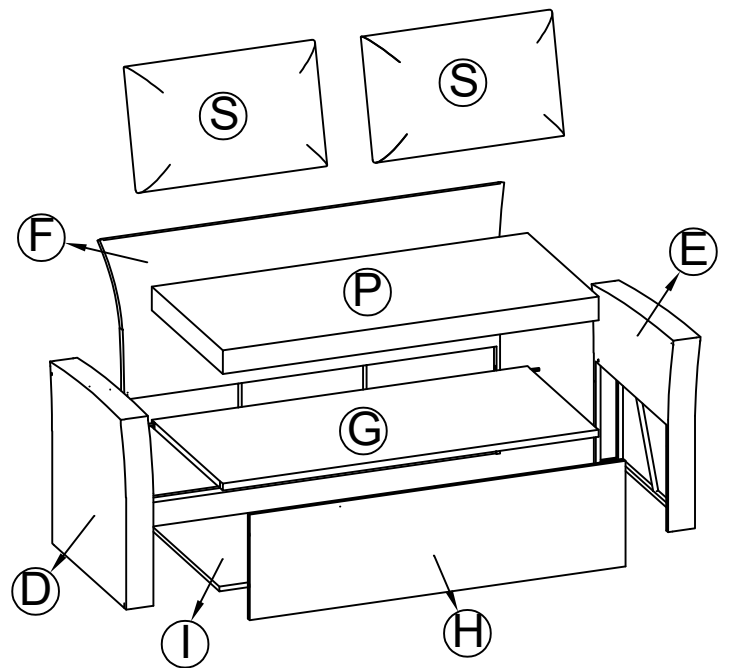

Note:

1. 50% Tighten before fixing all screws, Allen wrench is recommended instead of an electric drill.
2. Place the item on a flat ground to adjust and make sure it remains stable.
3. Tighten up all screw with tools gradually.
4. If screw are not aligned with holes during assembly, please loosen all the other screws to 50% and continue the assembly process.
5. If the item is not stable, please loosen all screws, adjust it on a flat ground and tighten up all screws again.
6. Note: If one or some screws are fully tighten during assembly, chances are the others will not be aligned with holes. In addition, all the holes are designed to be relatively larger to provide more space for the adjustment of the screws.

CARTON CONTENT:

WF299720

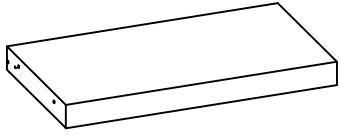

ⓑ x1

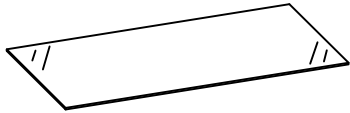

ⓒ x1

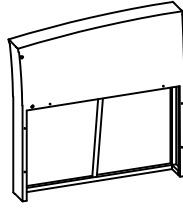

ⓓ x3

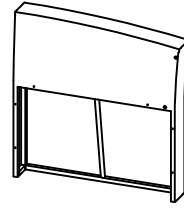

ⓔ x3



Hardware

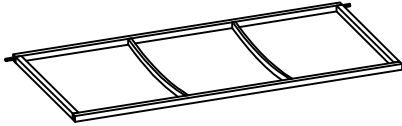

ⓖ x1

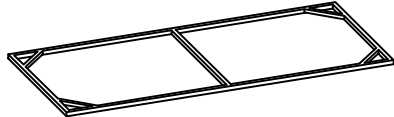

Ⓢ x1

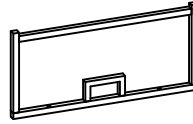

Ⓜ x1



Ⓝ x1



Ⓞ x2

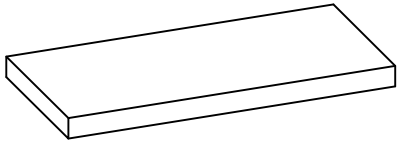

Ⓟ x1

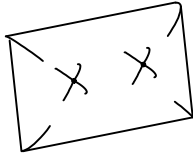

Ⓢ x2

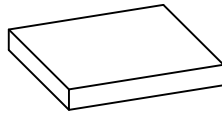

Ⓠ x2

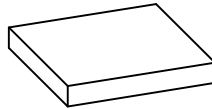

Ⓡ x1



Ⓣ x1

WF299721

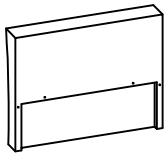

Ⓐ x2

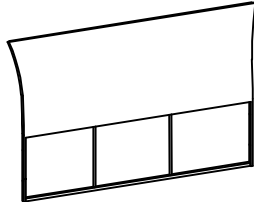

Ⓕ x1



Ⓗ x1

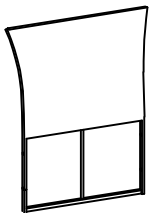

Ⓝ x2

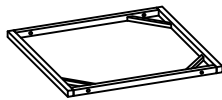

Ⓚ x2

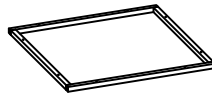

Ⓛ x2

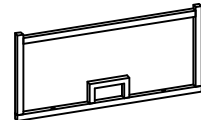

Ⓜ x1

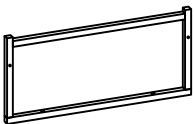

Ⓝ x1



Ⓞ x2

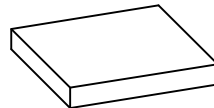



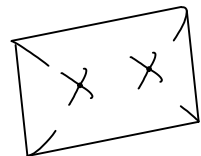



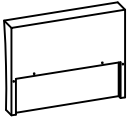
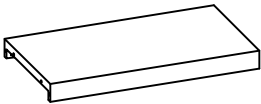

Ⓡ x1

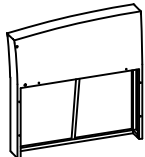
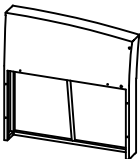
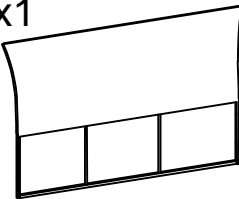
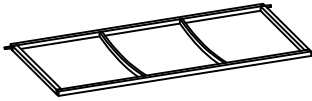

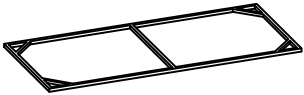
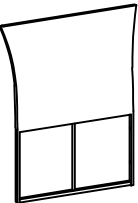
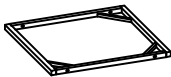
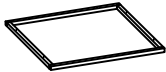
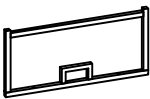

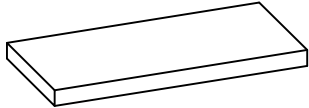
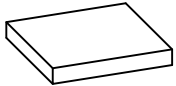
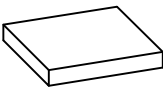
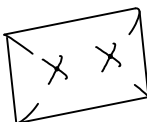

Ⓢ x2

Part List:

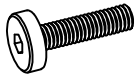
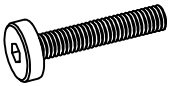
<p>A x2</p>  <p>Table Leg</p>	<p>B x1</p>  <p>Table Panel</p>	<p>C x1</p>  <p>Table Glass</p>	<p>D x3</p>  <p>Arm Right</p>
<p>E x3</p>  <p>Arm Left</p>	<p>F x1</p>  <p>Back Bench</p>	<p>G x1</p>  <p>Seat Bench</p>	<p>H x1</p>  <p>Front Bench</p>
<p>I x1</p>  <p>Panel Bench</p>	<p>J x2</p>  <p>Back Chair</p>	<p>K x2</p>  <p>Seat Chair</p>	<p>L x2</p>  <p>Seat Ottoman</p>
<p>M x2</p>  <p>Front Ottoman</p>	<p>N x2</p>  <p>Behind Ottoman</p>	<p>O x4</p>  <p>Side Otoman</p>	<p>P x1</p>  <p>Seat Bench Cushion</p>
<p>Q x2</p>  <p>Seat Chair Cushion</p>	<p>R x2</p>  <p>Seat Ottoman Cushion</p>	<p>S x4</p>  <p>Back Cushion</p>	<p>T x1</p>  <p>Table Top</p>

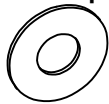
Hardware List:

<p>1 x 52 pcs Extra 4 pcs</p>  <p>BOLT M6 x 30MM</p>	<p>2 x 8 pcs Extra 2 pcs</p>  <p>BOLT M6 x 40MM</p>	<p>3 x 6 pcs Extra 2 pcs</p>  <p>BOLT M6 x 100MM</p>	<p>4 x 66 pcs Extra 7 pcs</p>  <p>WASHER M6</p>
<p>5 x 2 pcs</p>  <p>ALLEN KEY</p>			

STEP 1

- A** x 1
- B** x 1
- 1** x 4
- 4** x 4

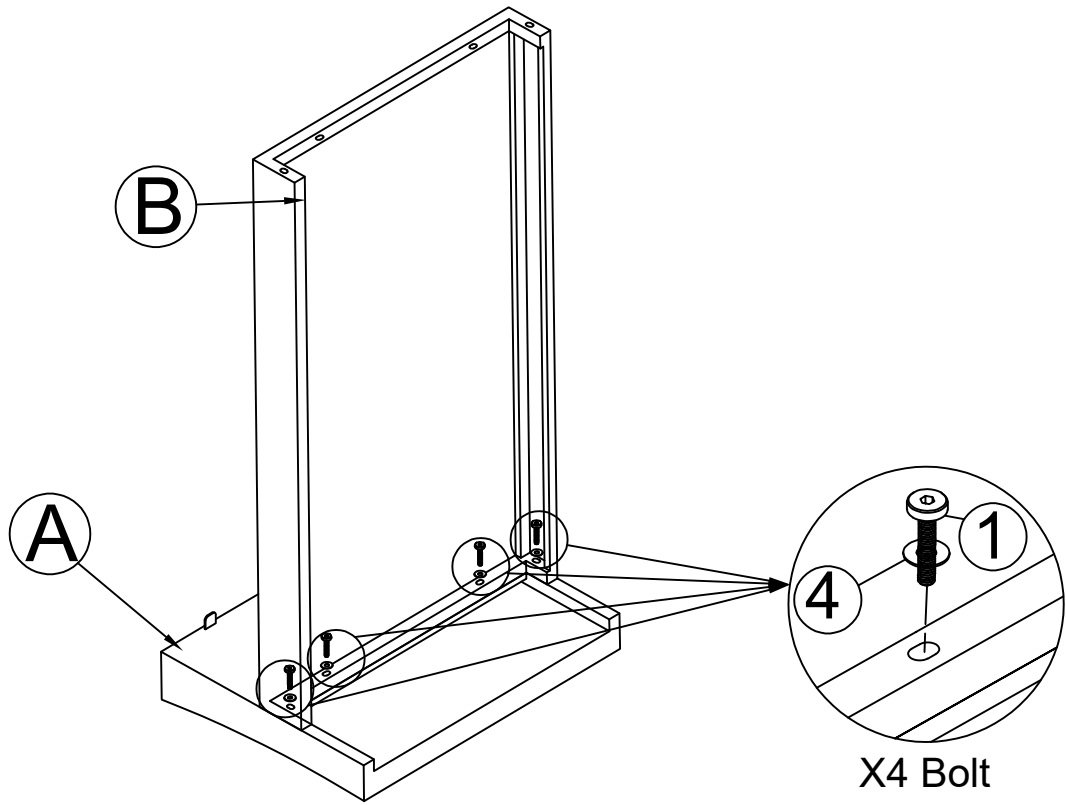
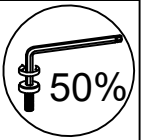

Connect The Table Leg (A) & Table Panel (B), tighten Bolt (1), Flat Washer (4) with Allen Key (5).

STEP 2

- A** x 1
- 1** x 4
- 4** x 4

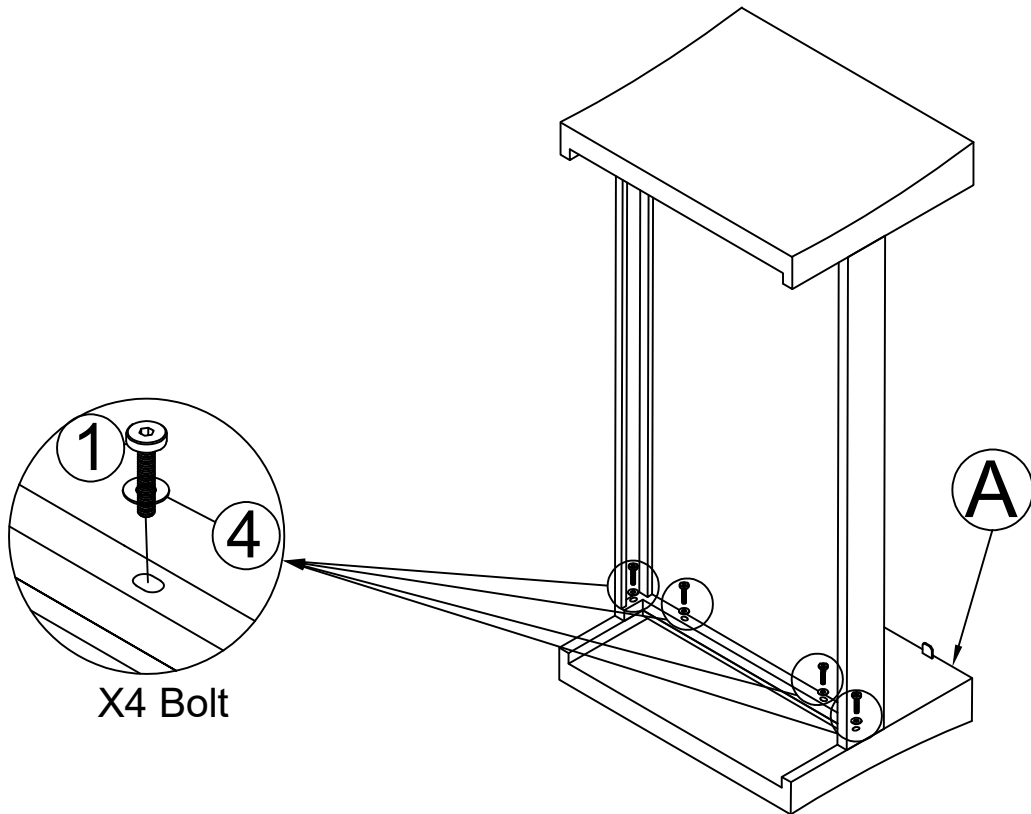
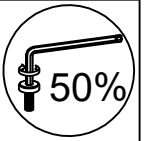

Connect The Part from STEP 1 & Table Leg (A), tighten Bolt (1), Flat Washer (4) with Allen Key (5).

STEP 3

(T) x 1

(1) x 4

(4) x 4

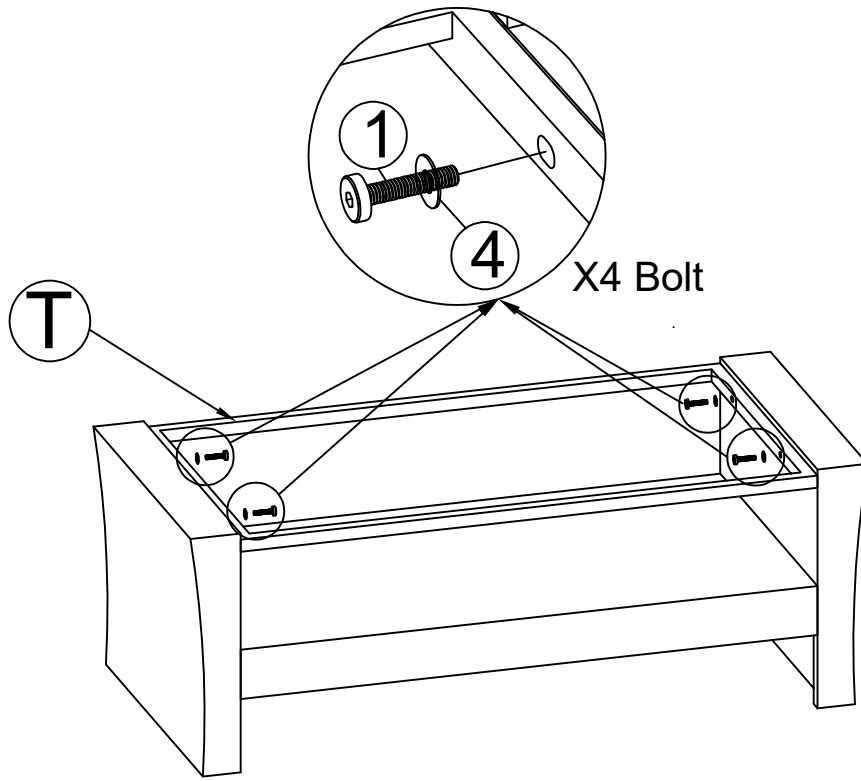

Connect The Part from STEP 2 & Table Top (T), tighten Bolt (1), Flat Washer (4) with Allen Key (5).

STEP 4

(C) x 1

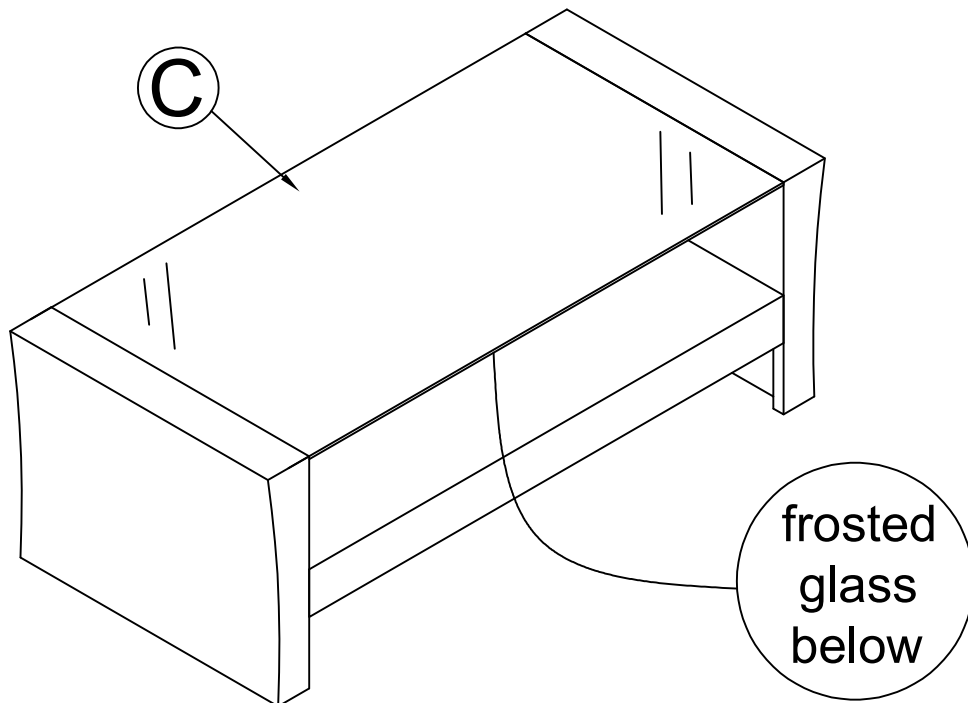

Put the Table upright and make sure all legs are level, then firmly tighten Bolts with Allen Key (5) & Put Table Glass (C) on Table to finish Table.

STEP 5

- D** x 1
- F** x 1
- 1** x 2
- 4** x 2

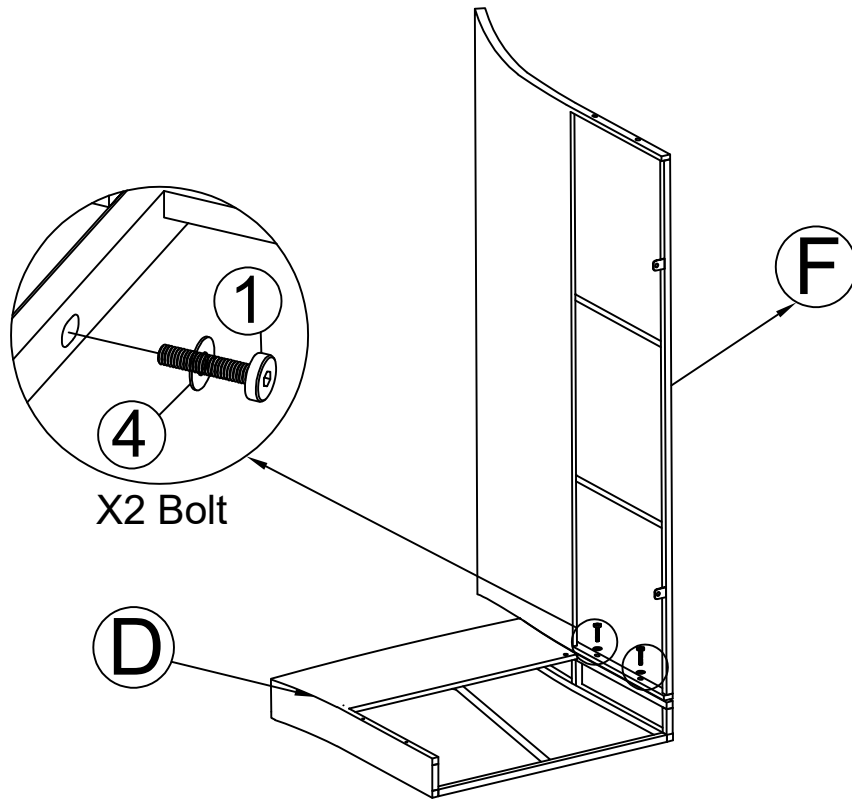
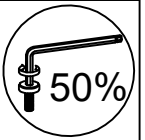

Connect The Arm Right (D) & Back Bench (F), tighten Bolt (1), Flat Washer (4) with Allen Key (5).

STEP 6

- G** x 8

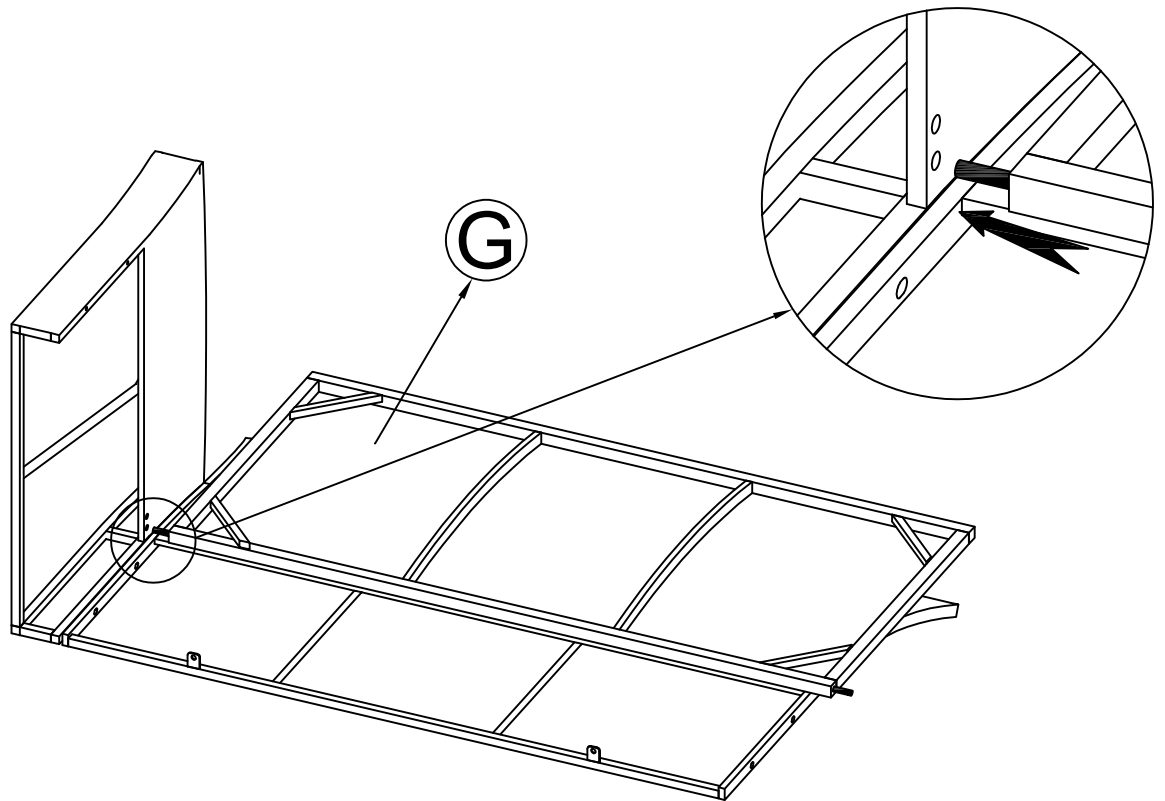

Connect The Part from STEP 4 & Seat Bench (G).

STEP 7

- E** x 1
- 1** x 2
- 4** x 2

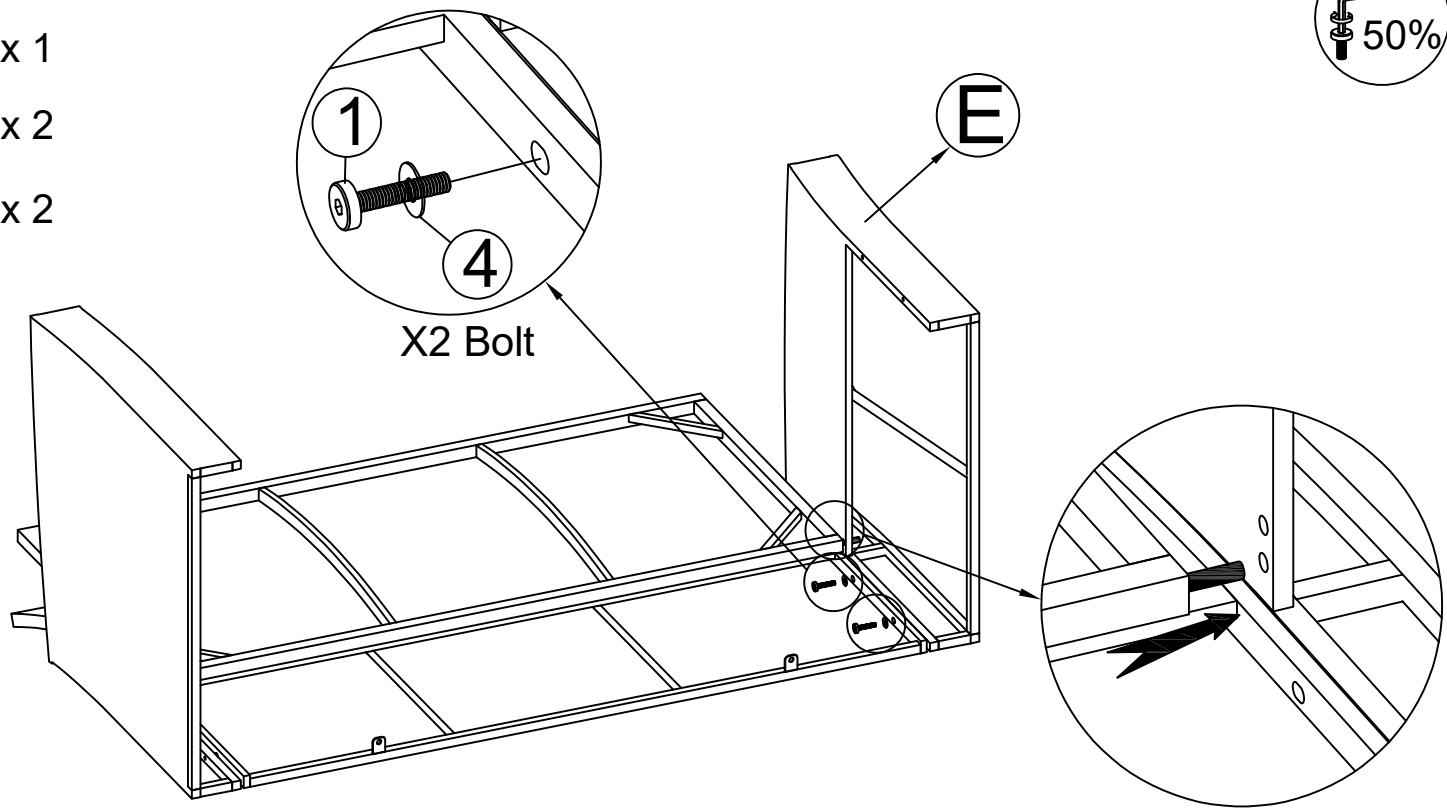

Connect The Part from STEP 5 & Arm Left (E), tighten Bolt (1), Flat Washer (4) with Allen Key (5).

STEP 8

- H** x 1
- 1** x 4
- 3** x 1
- 4** x 5

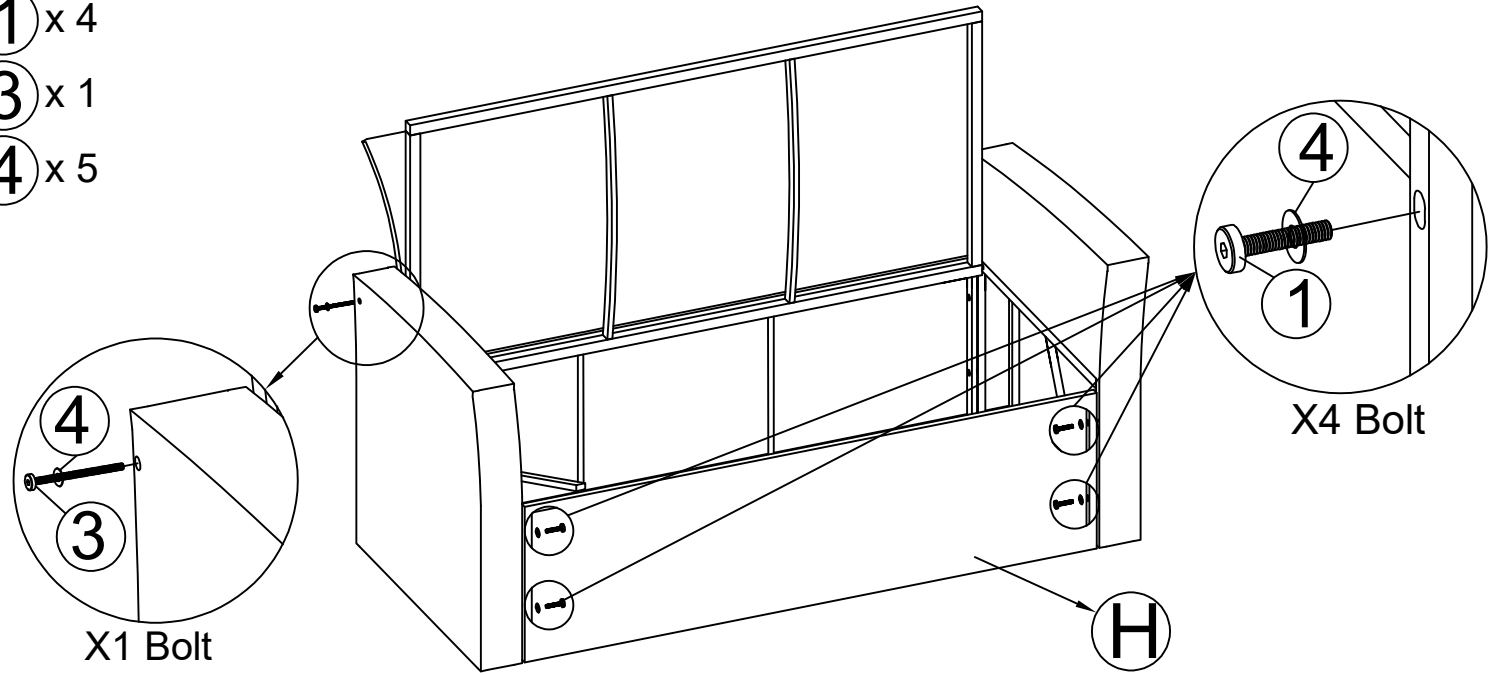

Connect The Part from STEP 6 & Front Bench (H), tighten Bolt (1), (3) Flat Washer (4) with Allen Key (5).

STEP 9

① x 1

③ x 1

④ x 1

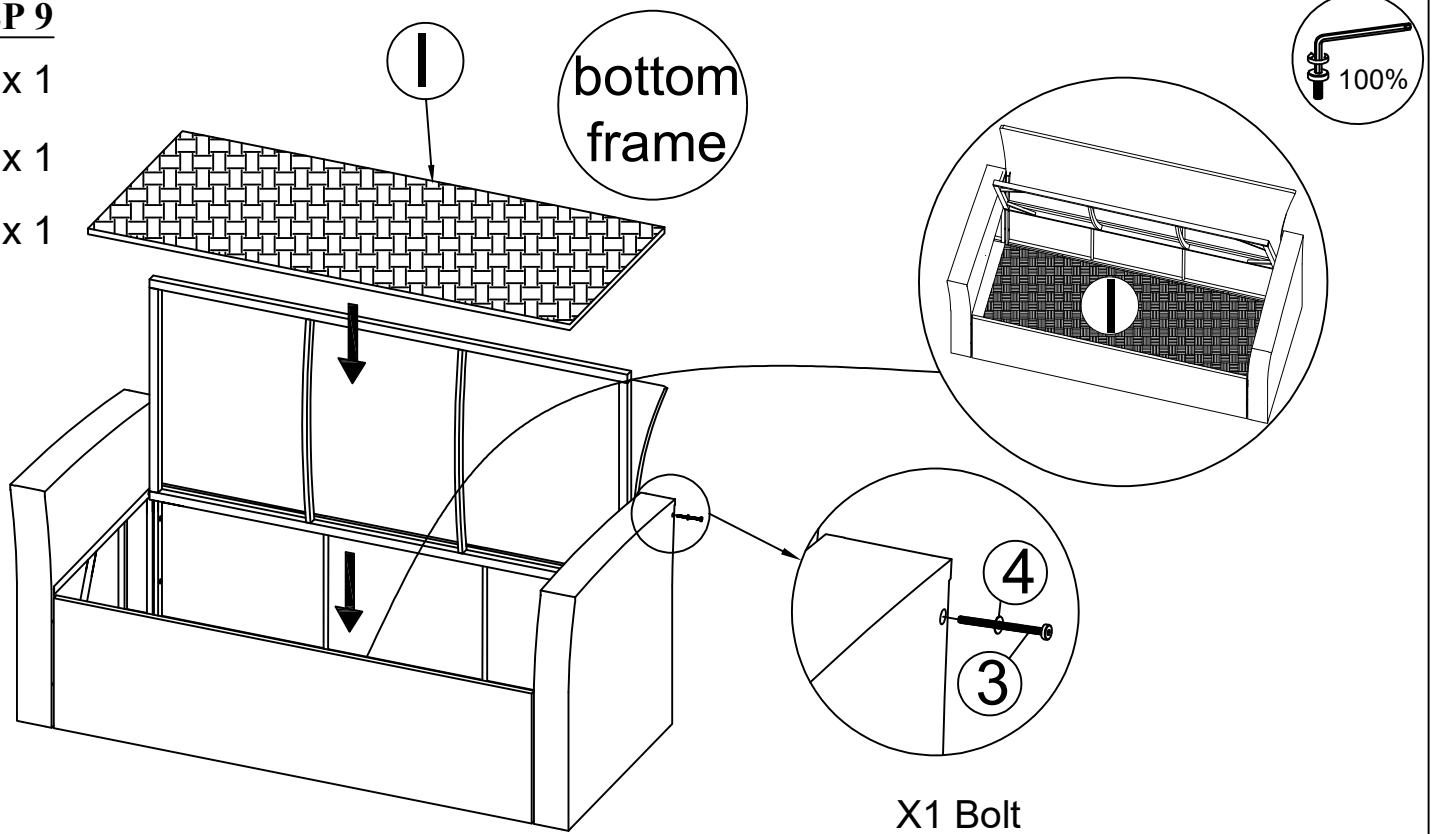

Connect The Part from STEP 7 & Panel Bench (1).

STEP 10

⑤ x 2

⑥ x 1

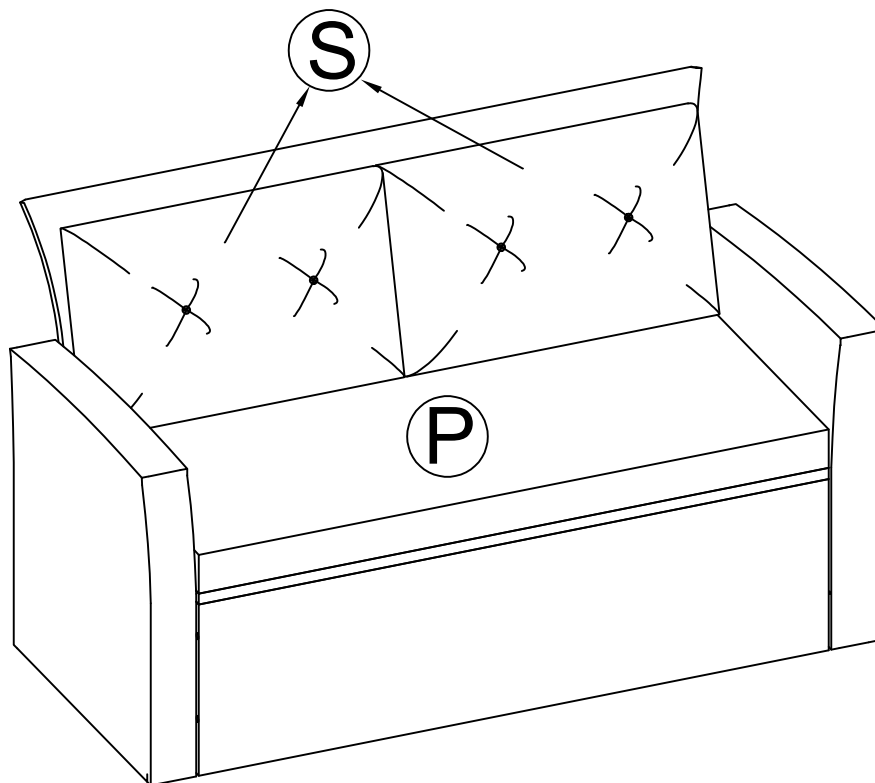

Put the Bench upright and make sure all legs are level, then firmly tighten Bolts with Allen Key (5). Put on Seat Bench Cushion (P) & Back Cushion (S) to finish Bench.

STEP 11

- D** x 1
- J** x 1
- 1** x 2
- 4** x 2

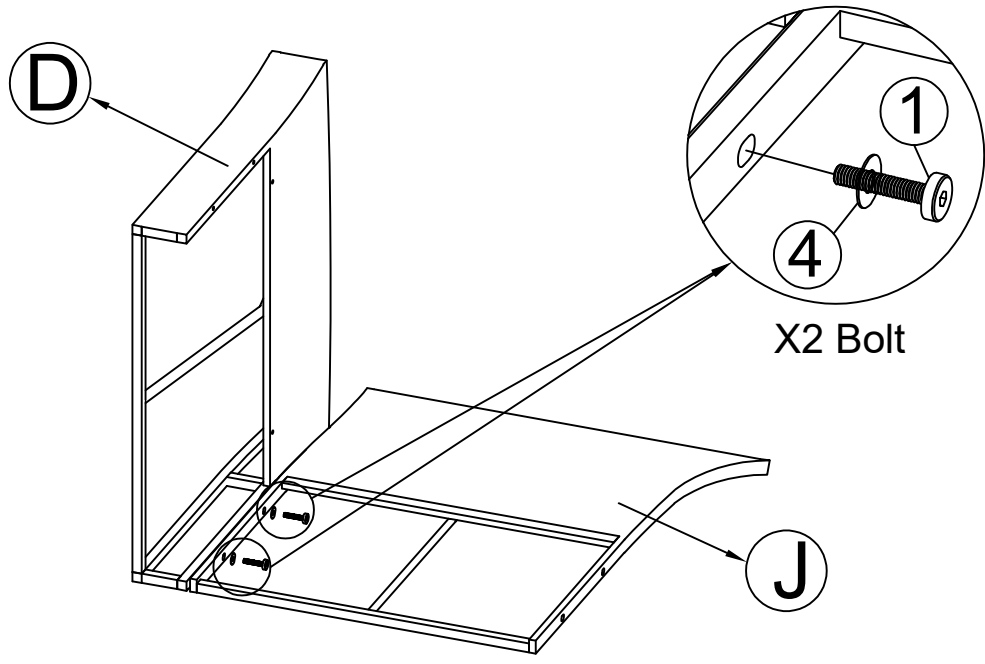

Connect The Arm Left (E) & Back Chair (J), tighten Bolt (1), Flat Washer (4) with Allen Key (5).

STEP 12

- E** x 1
- 1** x 2
- 3** x 1
- 4** x 3

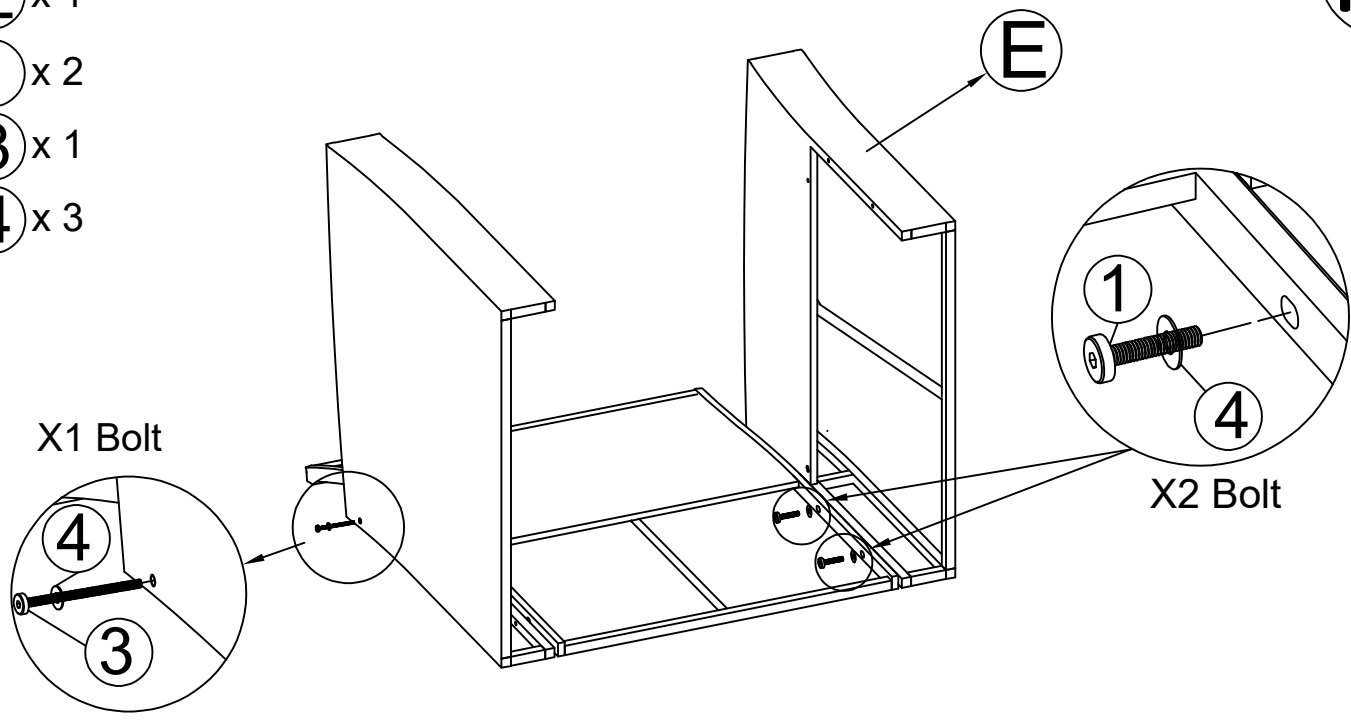

Connect The Part from STEP 11 & Arm Left (E), tighten Bolt (1), (3), Flat Washer (4) with Allen Key (5).

STEP 13

(K) x 1

(2) x 4

(3) x 1

(4) x 5

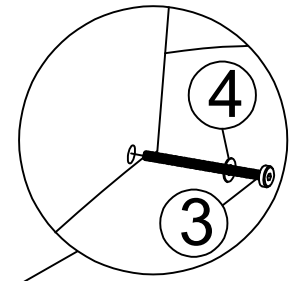
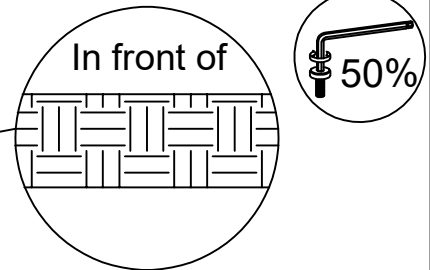
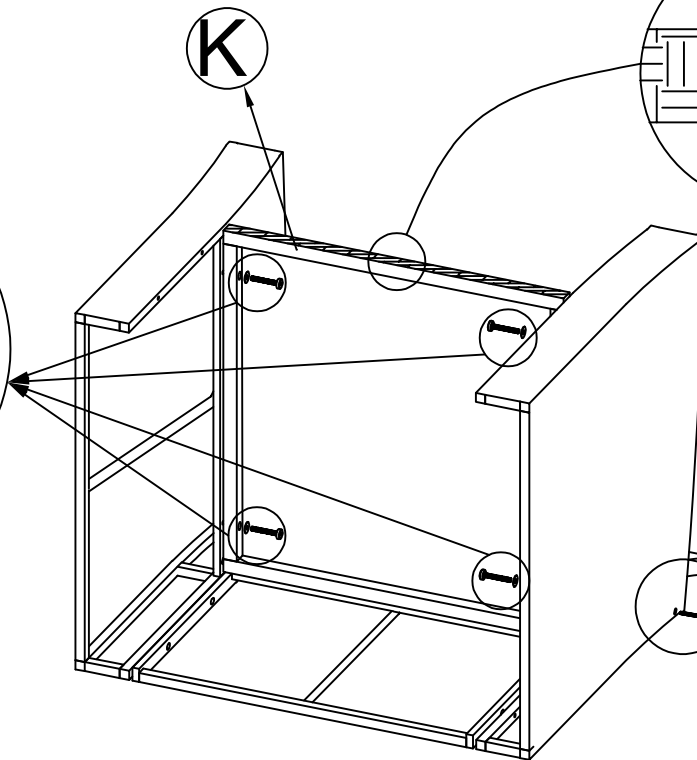
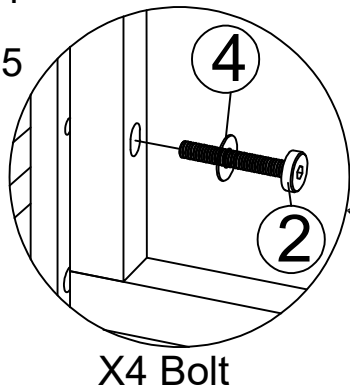

Connect The Part from STEP 12 & Seat Chair (K), tighten Bolt (2), Flat Washer (4) with Allen Key (5).

STEP 14

(S) x 1

(Q) x 1

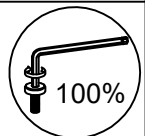
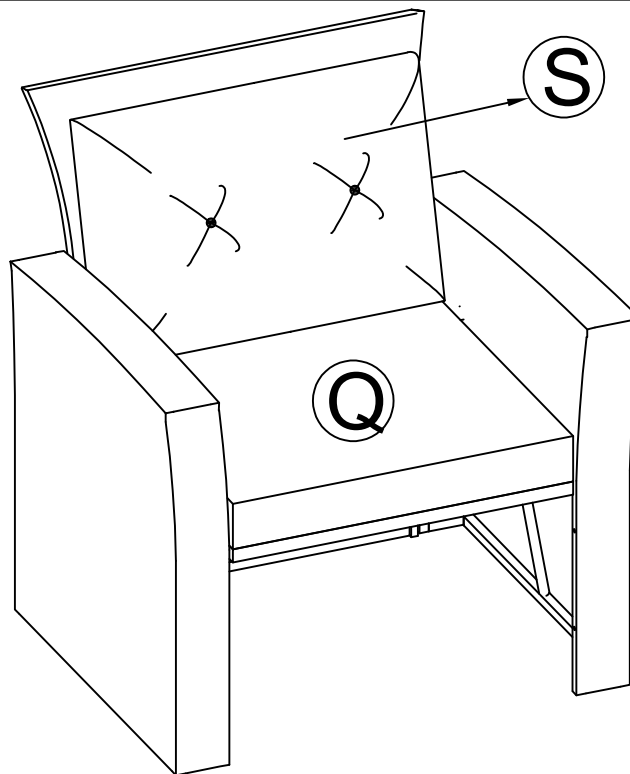

Put the Chair upright and make sure all legs are level, then firmly tighten Bolts with Allen Key (5) & Put on Seat Chair Cushion (Q) & Back Cushion (S) to finish Chair.

STEP 15

- L** x 1
- M** x 1
- N** x 1
- 1** x 4
- 4** x 4

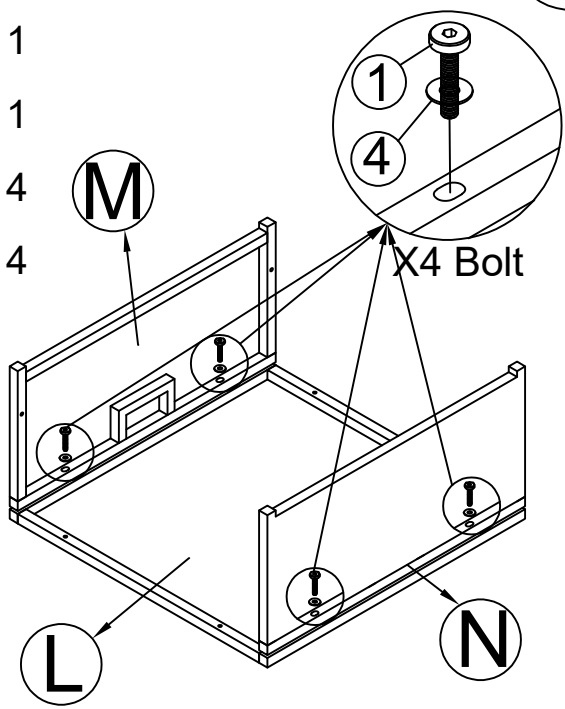

STEP 16

- O** x 2
- 1** x 8
- 4** x 8

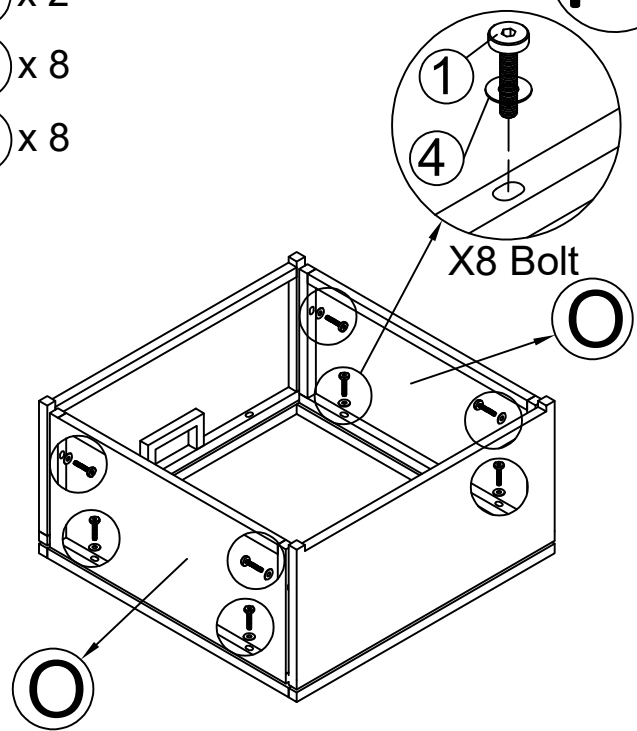

Connect The Seat Ottoman (L) & Front Ottoman (M), Behind Ottoman (N), tighten Bolt (1), Flat Washer (4) with Allen Key (5).

Connect The Part from STEP 15 & Side Ottoman (O), tighten Bolt (1), Flat Washer (4) with Allen Key (5).

STEP 17

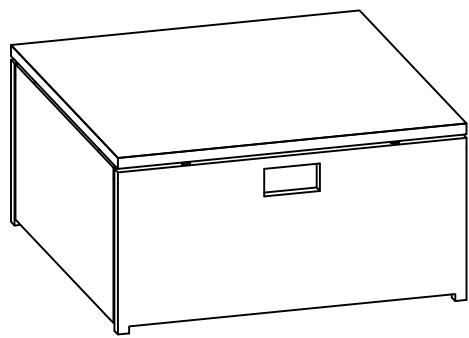
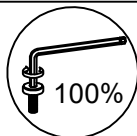

Put the Ottoman upright and make sure all legs are level, then firmly tighten Bolts with Allen Key (5)

STEP 18

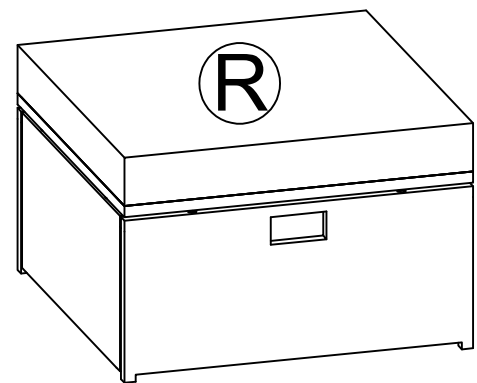

Put on Seat Ottoman Cushion (R) to finish Ottoman.

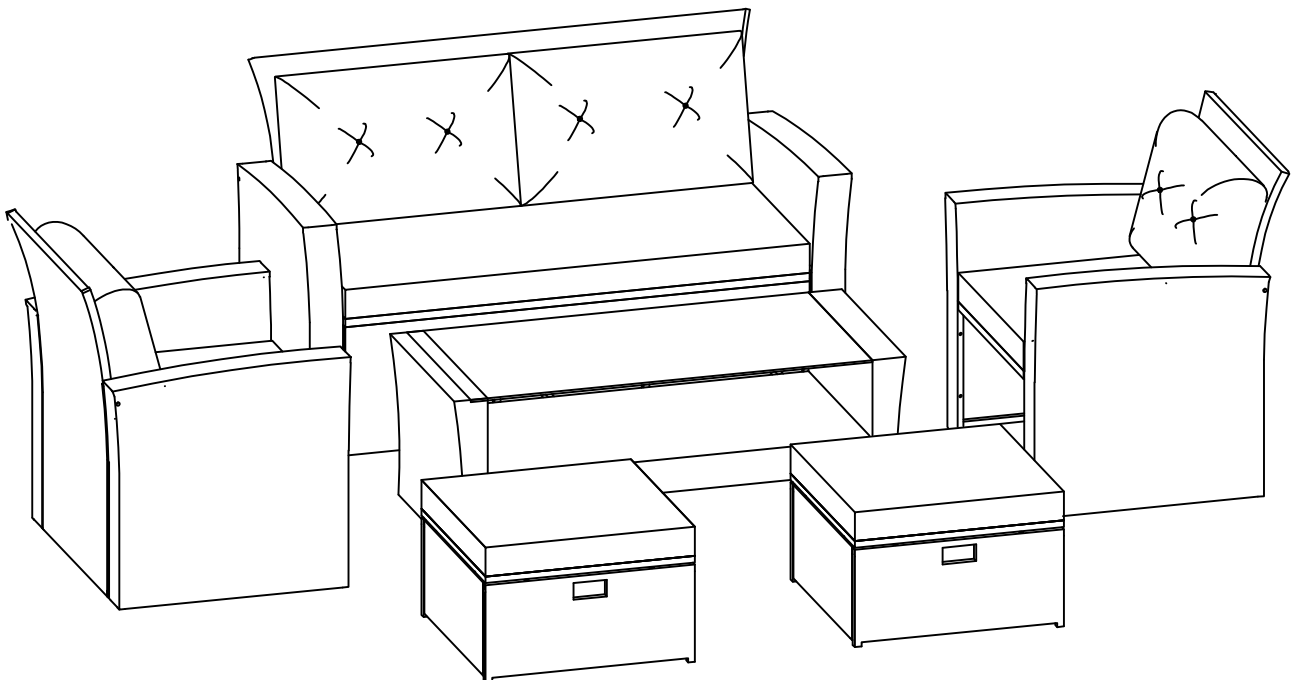
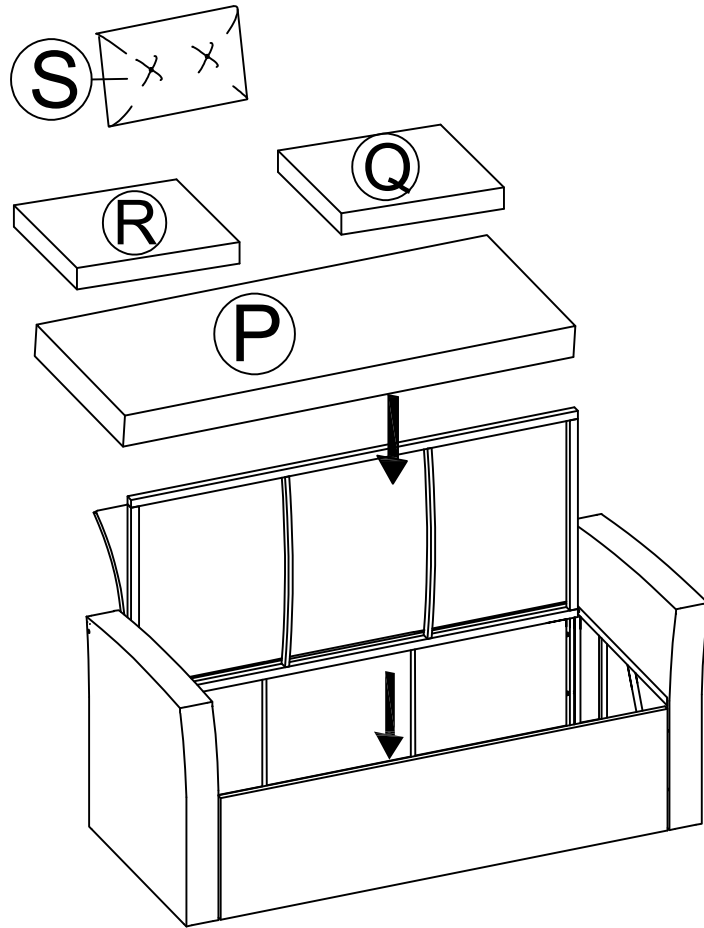

Finish Sofa Option 1

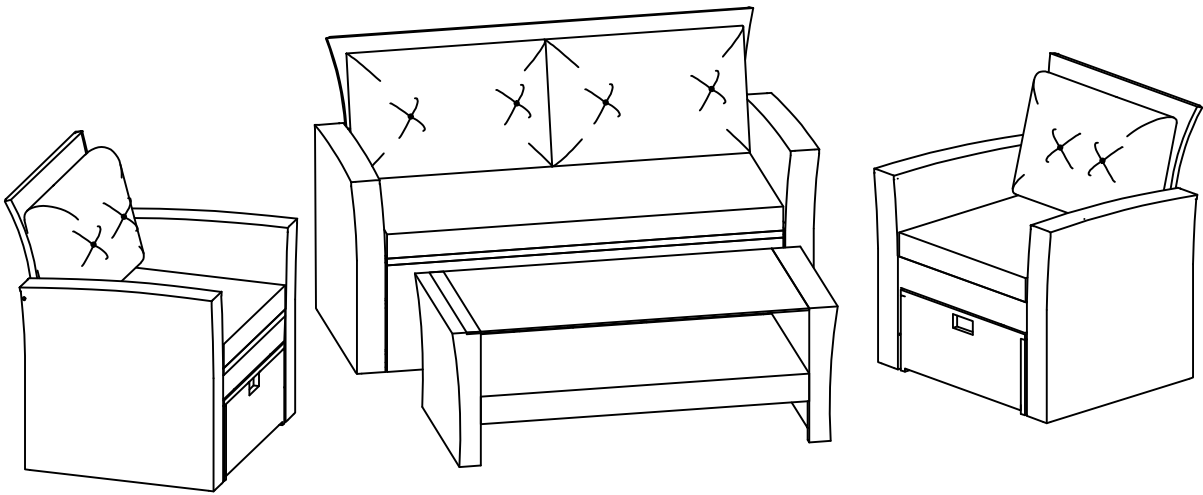

Finish Sofa Option 2

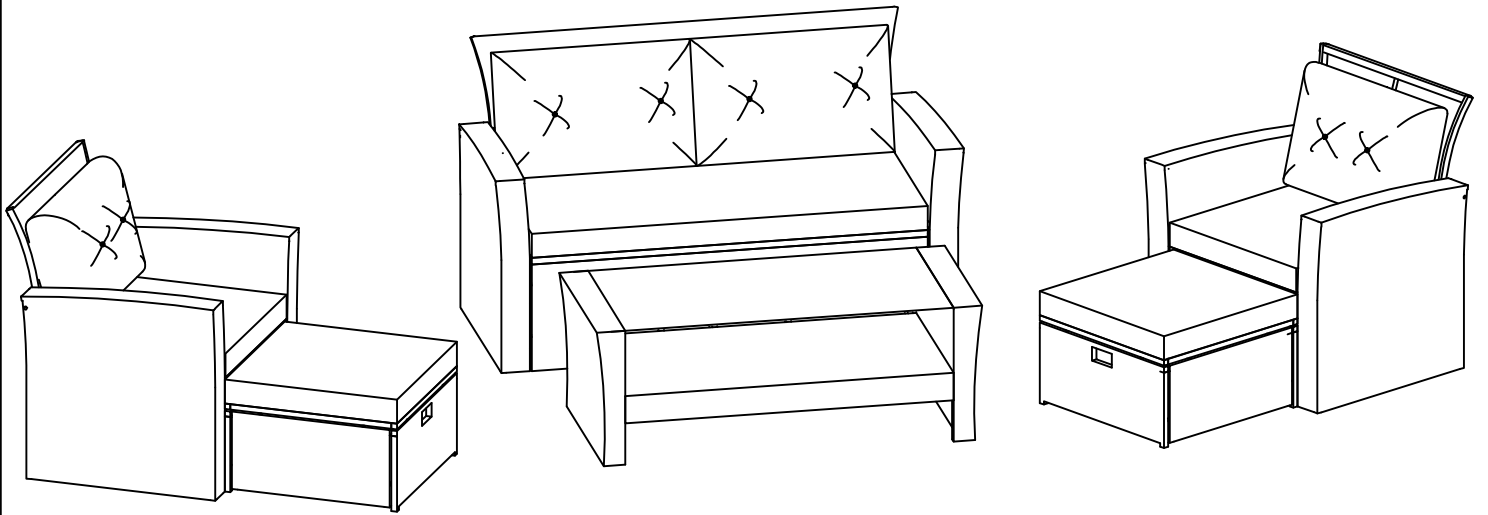

Finish Sofa Option 3