

Installation Instruction

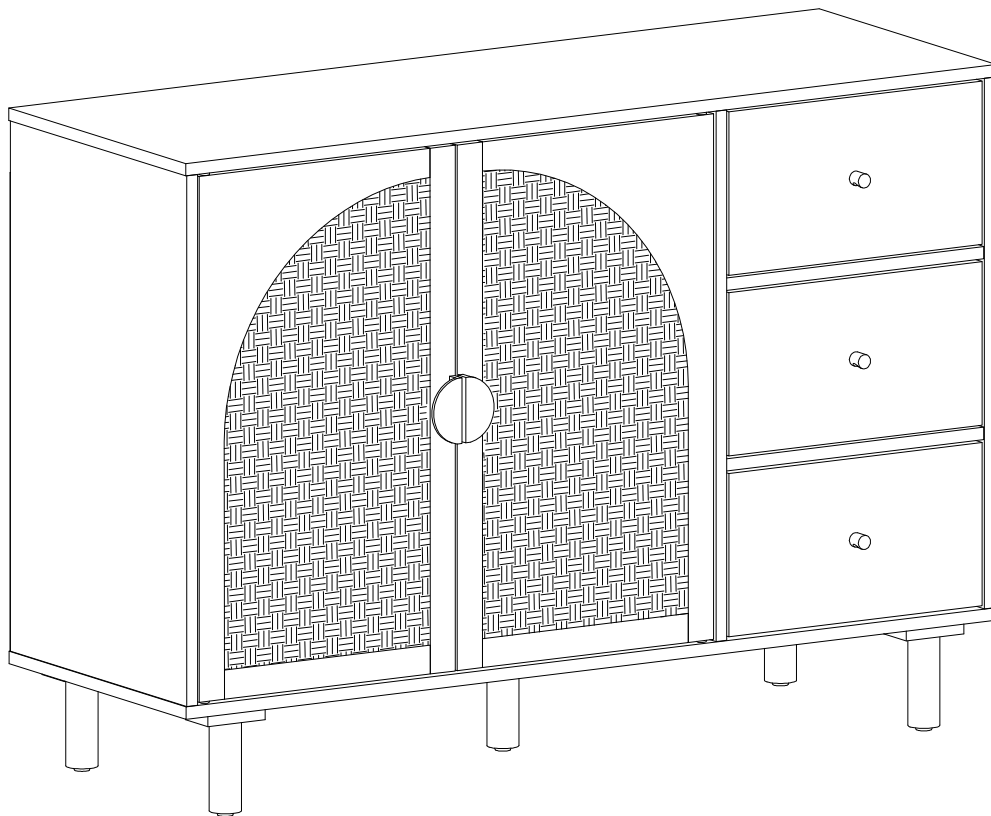

Product name

2 Door 3 Drawer Cabinet

Ver.1.0 20230920

Assembling

What you need

- Use the packaging carton as a working surface to prevent product damage during assembly
- Phillips head screwdriver

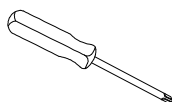

Weight Limitation



44 | 22

lbs table top | lbs per shelf



2 PERSONS

What's included

Code	Description	Qty
A	Cam Lock 15 x 12 mm	22
B	Small Cam Lock 15 x 9 mm	13
C	Cam Bolts 6 x 34 mm	34
D	Wooden Dowel M8 x 30 mm	23
E	Handle for Door	2
F	Handle for Drawer	3
G	Flat Head Screw M4 x 28 mm	21
H	Flat Head Screw M4 x 38 mm	15
I	Flat Head Screw M4 x 50 mm	7
J	Bolt 5/32" x 19 mm	8
K	Wood Screw M3.5 x 15 mm	5
L	Wood Screw M3 x 12 mm	37
M	Washer Head Screw M3.5 x 15 mm	23
N	Metal Support	5
O	Magnetic Door Catcher	2
P	Slide Sets	3
Q	Round Head Screw M4x32 mm	2
R	Round Head Screw M4x18 mm	2
S	Anchor M6x30 mm	2
T	Metal Plate	4
U	Plastic Strap	2

The Hardwares

A

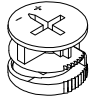

B



C

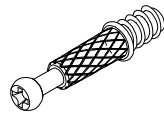

D

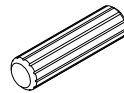

E

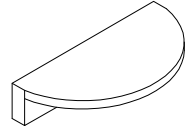

F

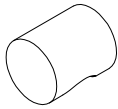

G



H



I



J



K



L



M



N



O

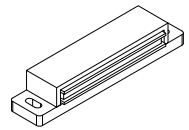

P

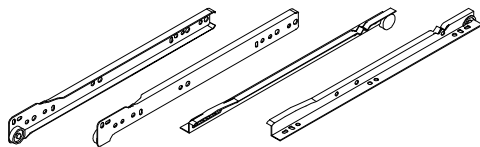

(CL) (CR) (DR) (DL)

Q

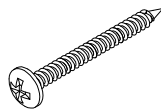

R

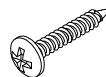

S

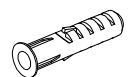

T

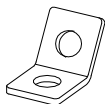

U

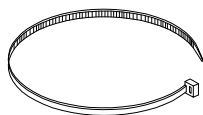

IMPORTANT:

1. Do not tighten bolts / screws completely until all bolts / screws are lined up and inserted into holes.
2. Do not over tighten screws and bolts to avoid stripping.
3. Please use hand tools to assemble this product. Do not use power tools.
4. Must need 2 people to assemble this product.



2 PERSONS

Included Accessories

Code	Description	Qty
1	Cabinet Top	1
2	Bottom Panel	1
3	Left Side Panel	1
4	Partition Panel	1
5	Right Side Panel	1
6	Top Back Stretcher	1
7	Back Panel	1
8	Top Stretcher	1
9	Support Panel	1
10	Shelf	1
11	Leg	5
12	Drawer Front Panel	3
13	Drawer Left Side Panel	3
14	Drawer Right Side Panel	3
15	Drawer Back Panel	3
16	Drawer Bottom Panel	3
17	Left Door	1
18	Right Door	1

The Accessoriess

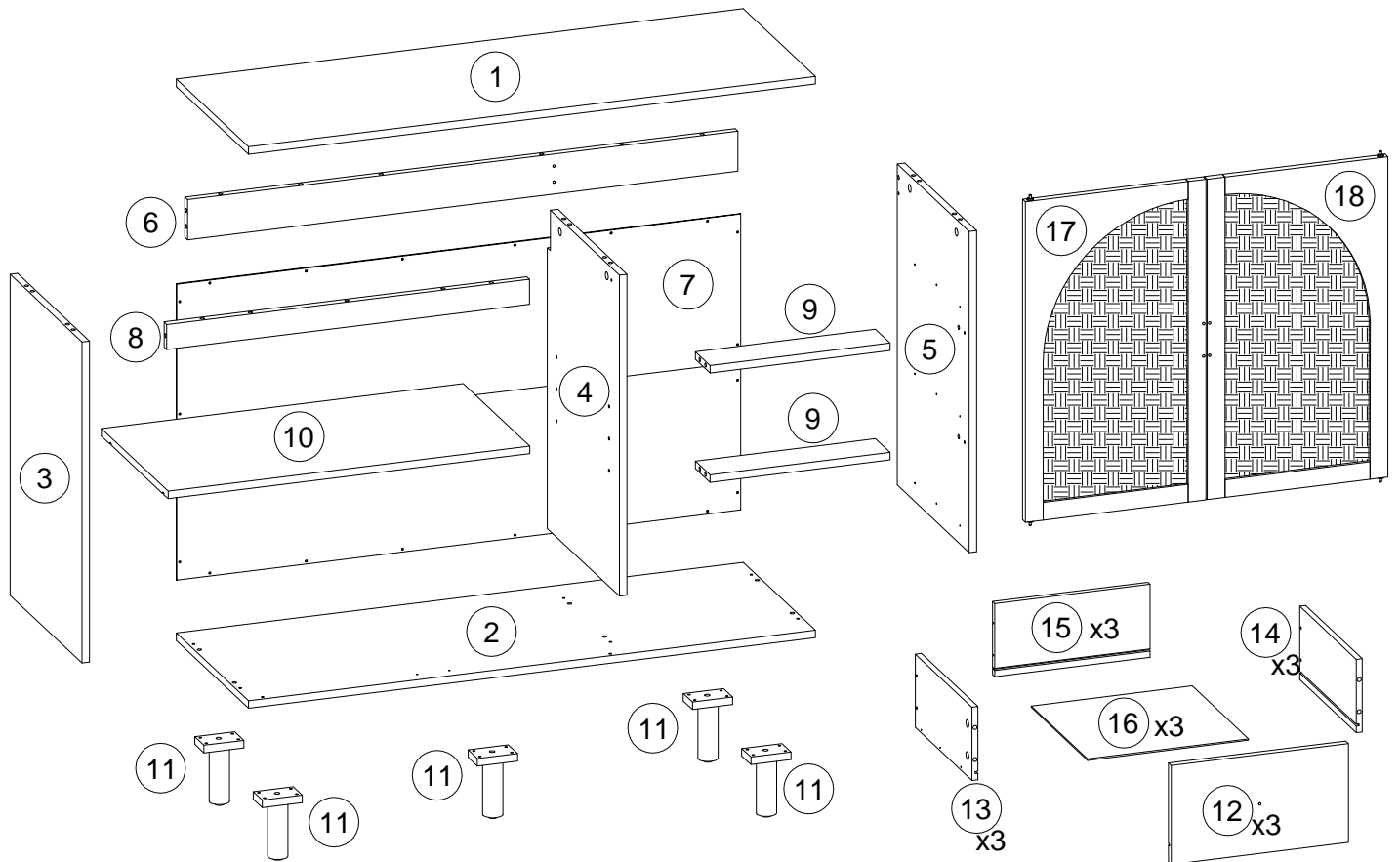

Noted :

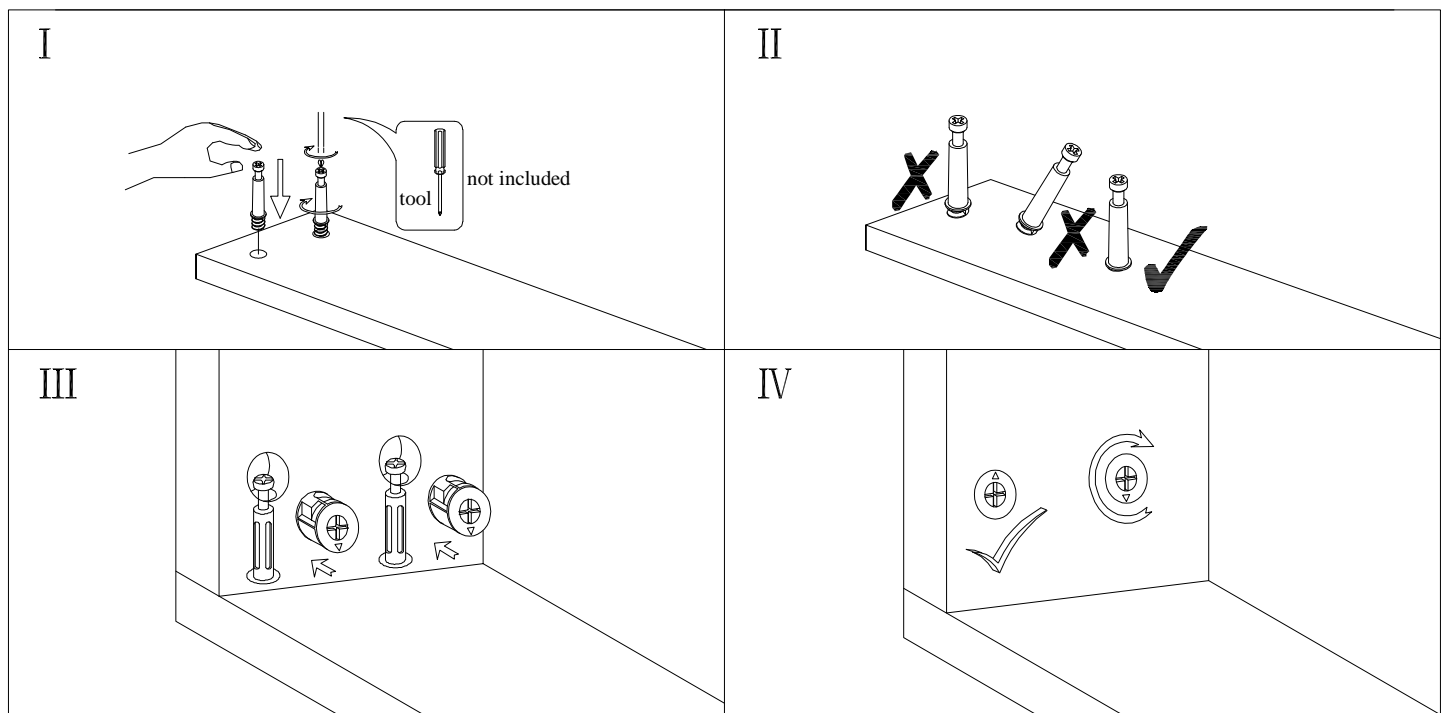

Step 1

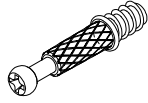
C	x13
	

K	x 4
	

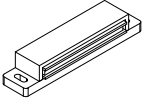
O	x 2
	

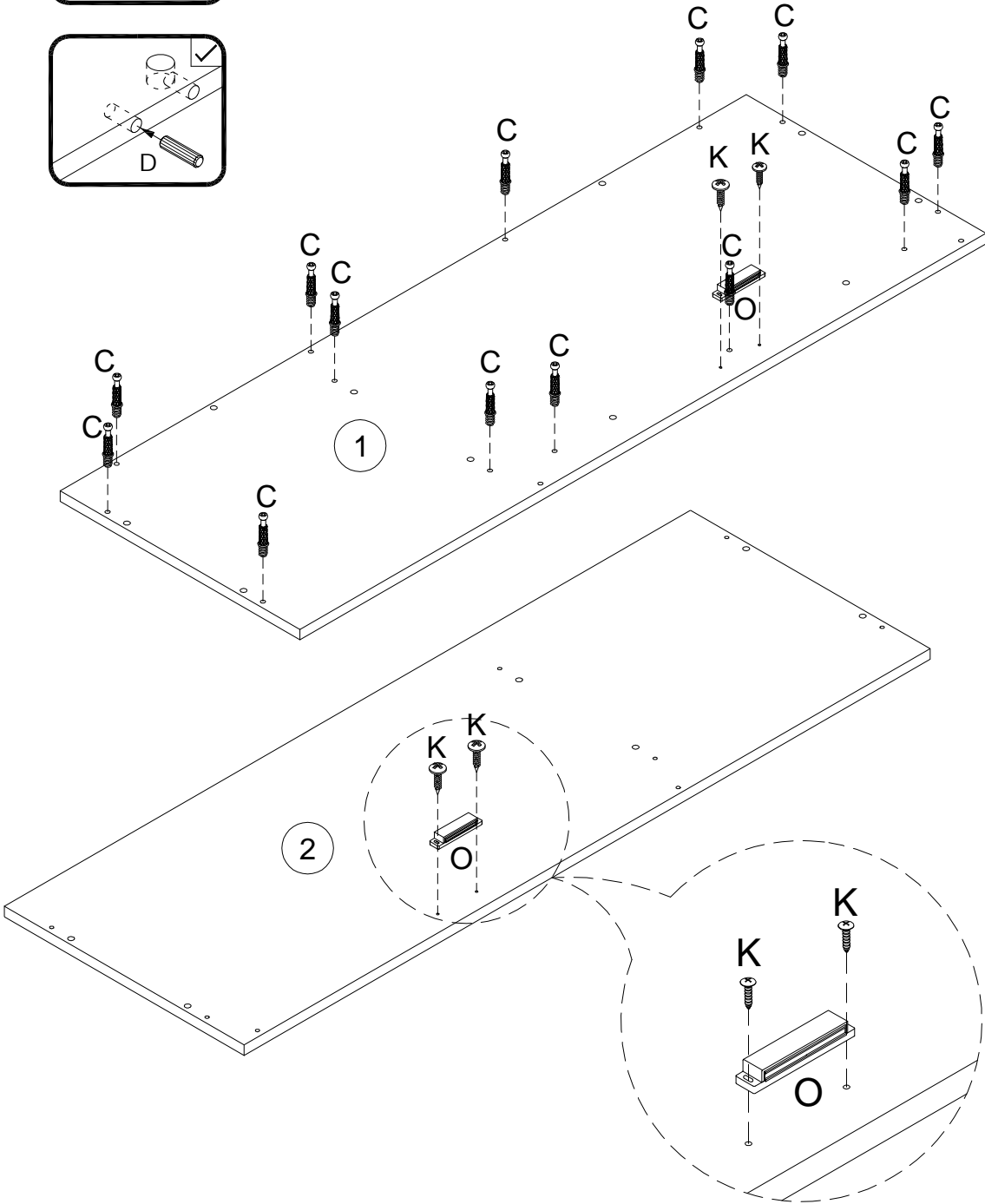
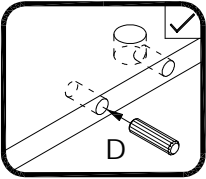
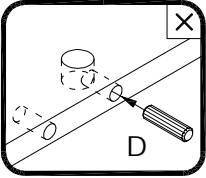

Step 2

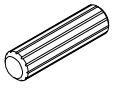
D	x 10
	

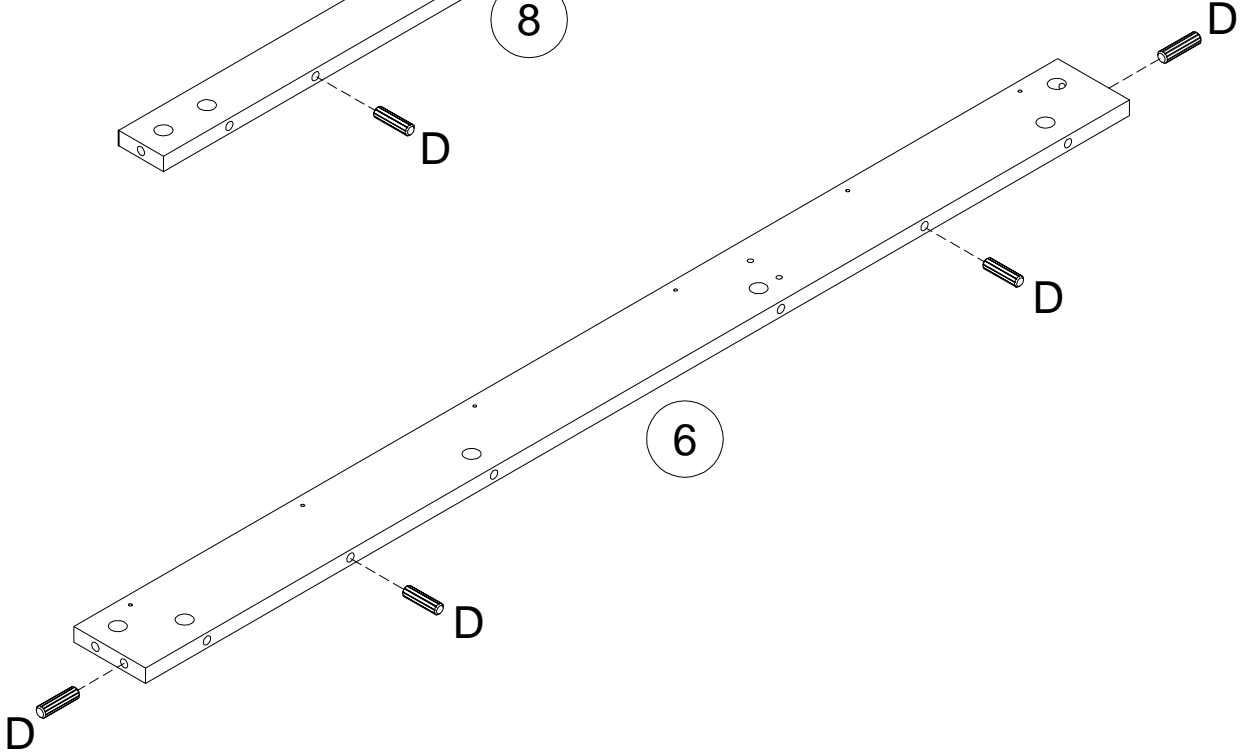
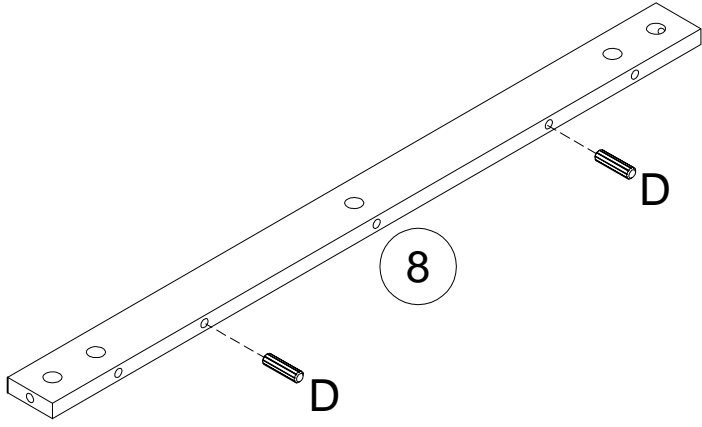
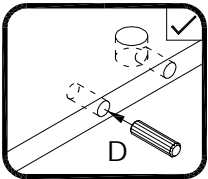
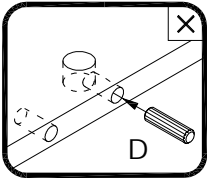
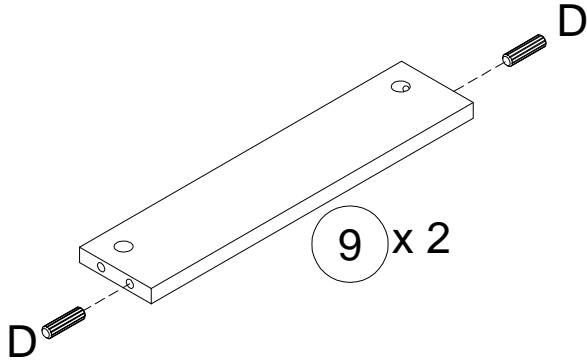

Step 3

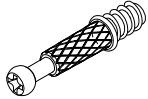
C	x14
	

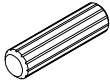
D	x 4
	

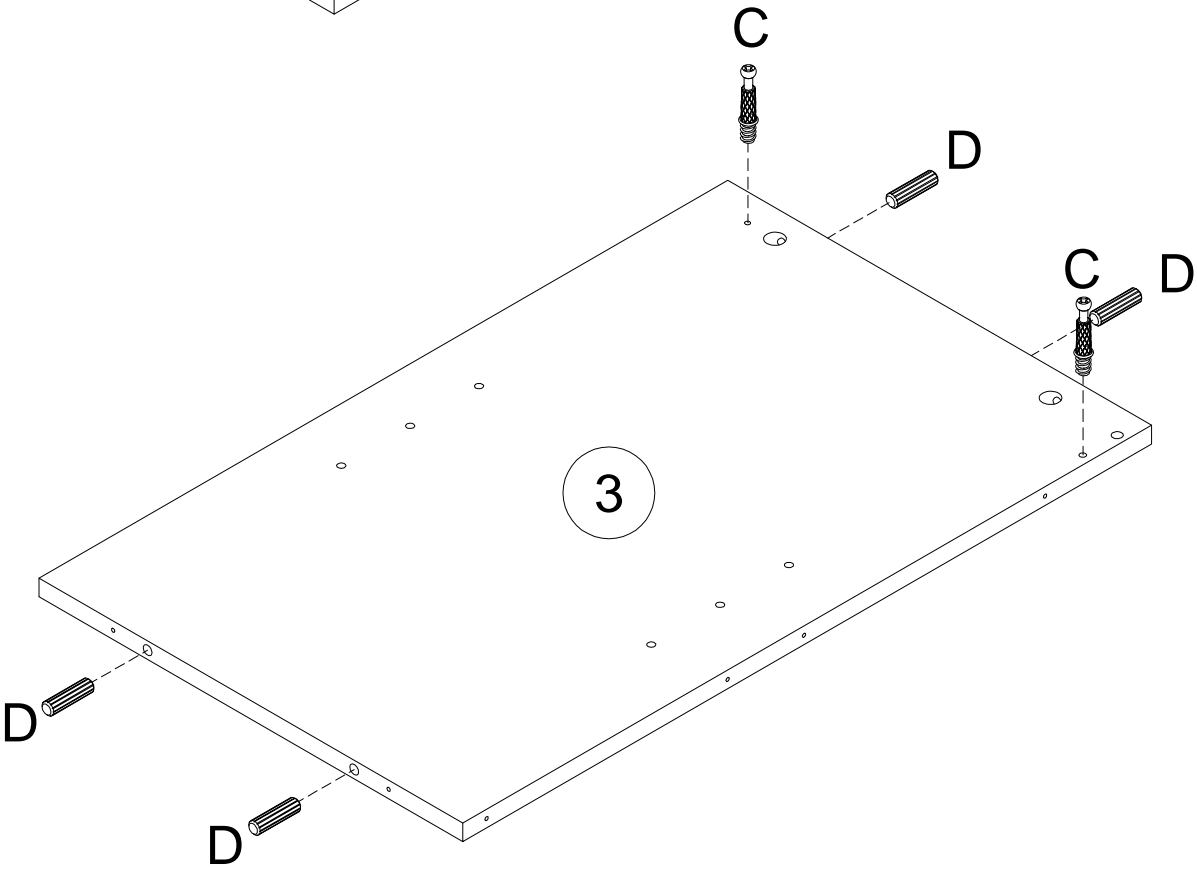
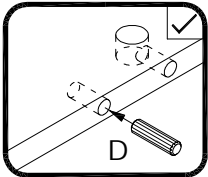
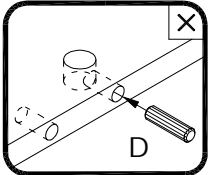
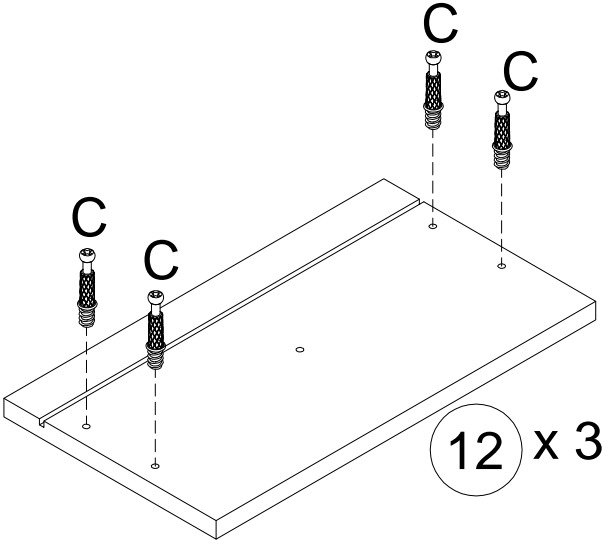

Step 4

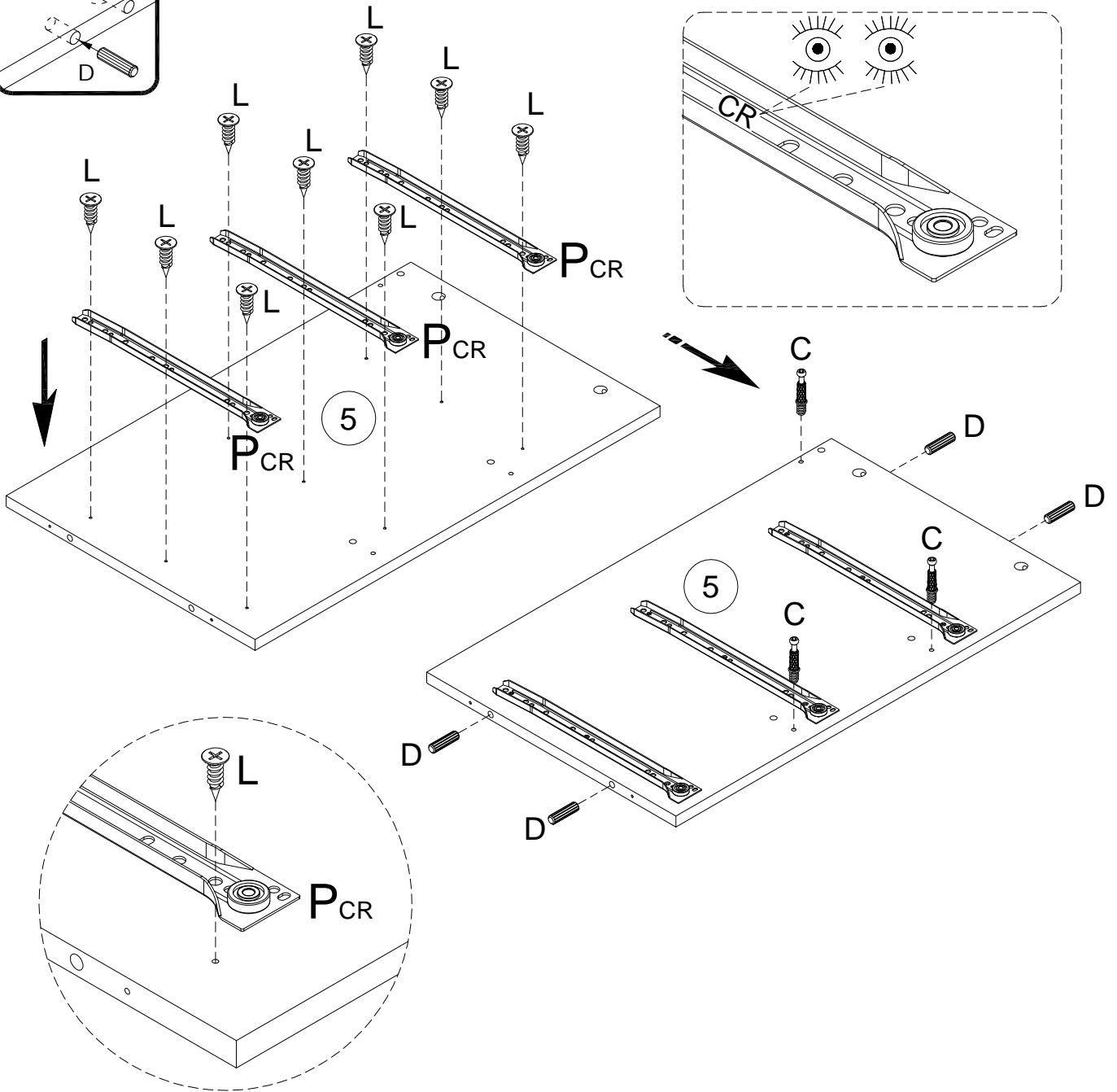
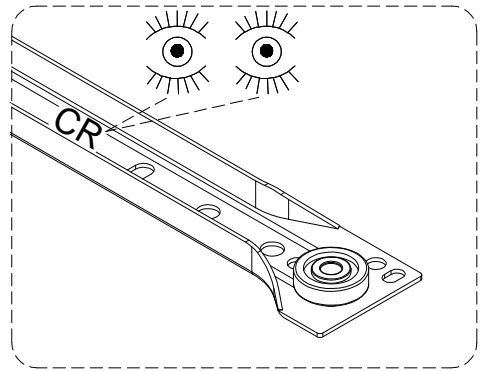
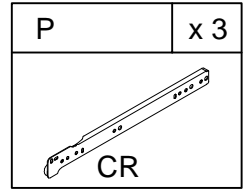
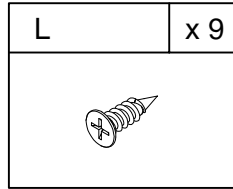
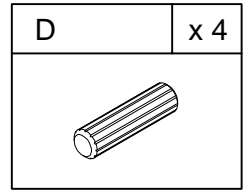
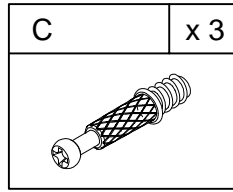
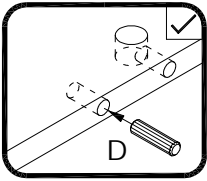
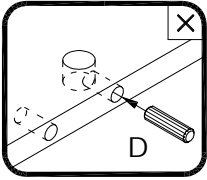

Step 5

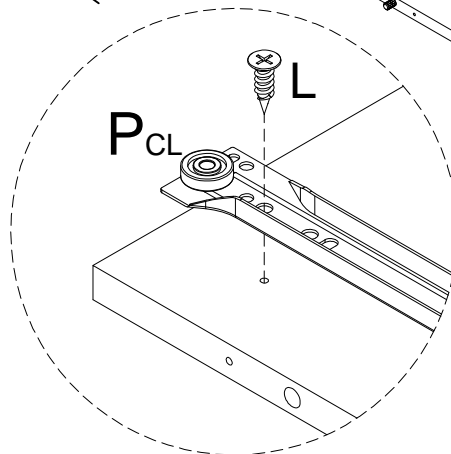
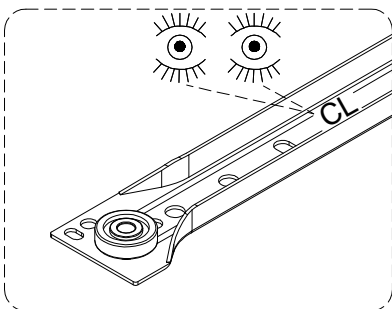
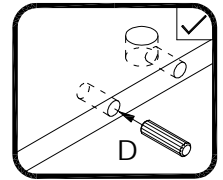
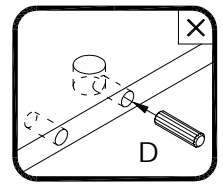
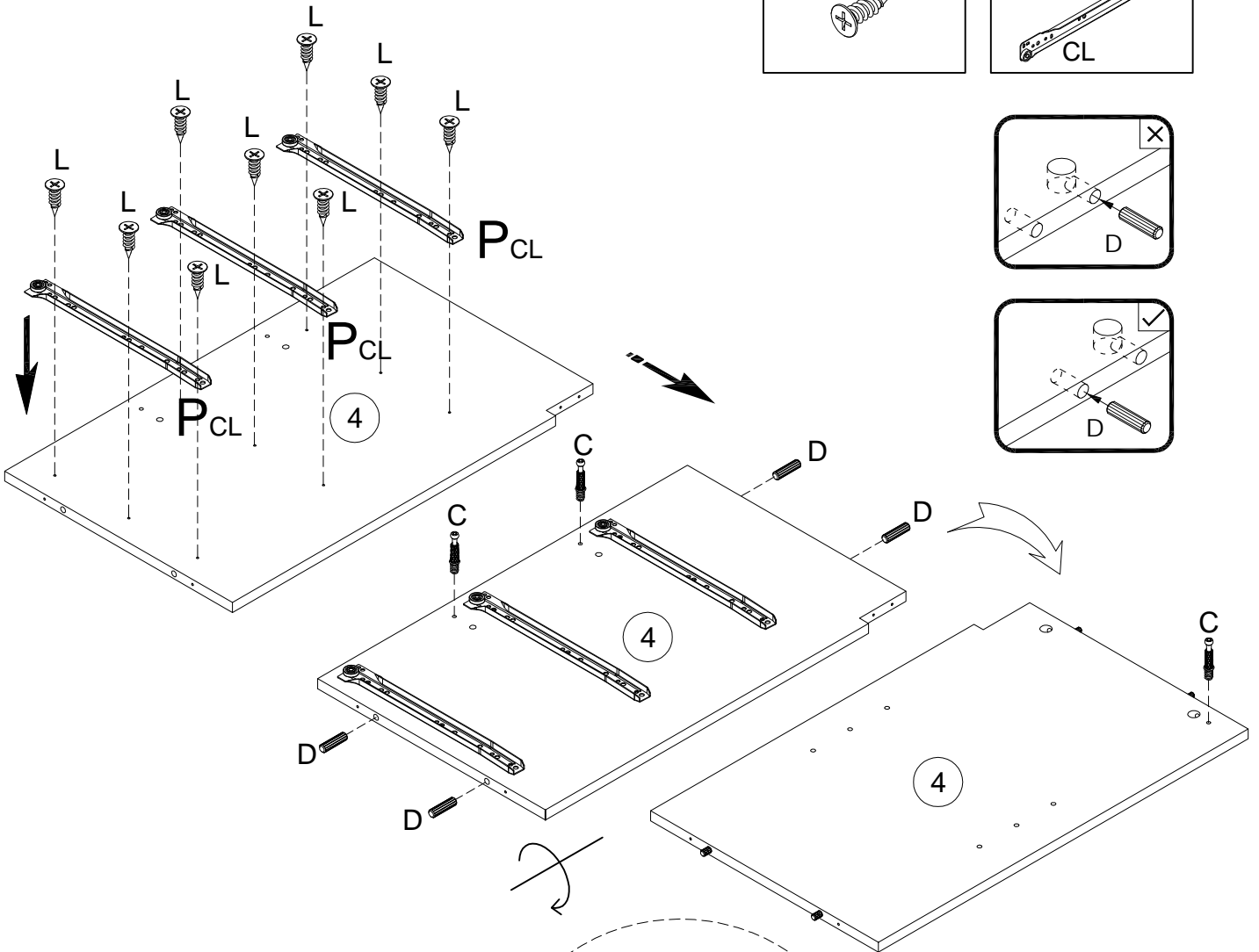
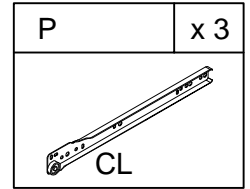
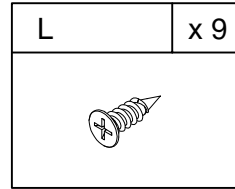
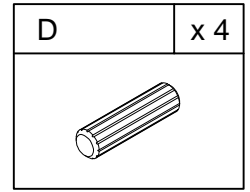
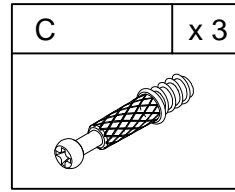

Step 6

A	x 4
	

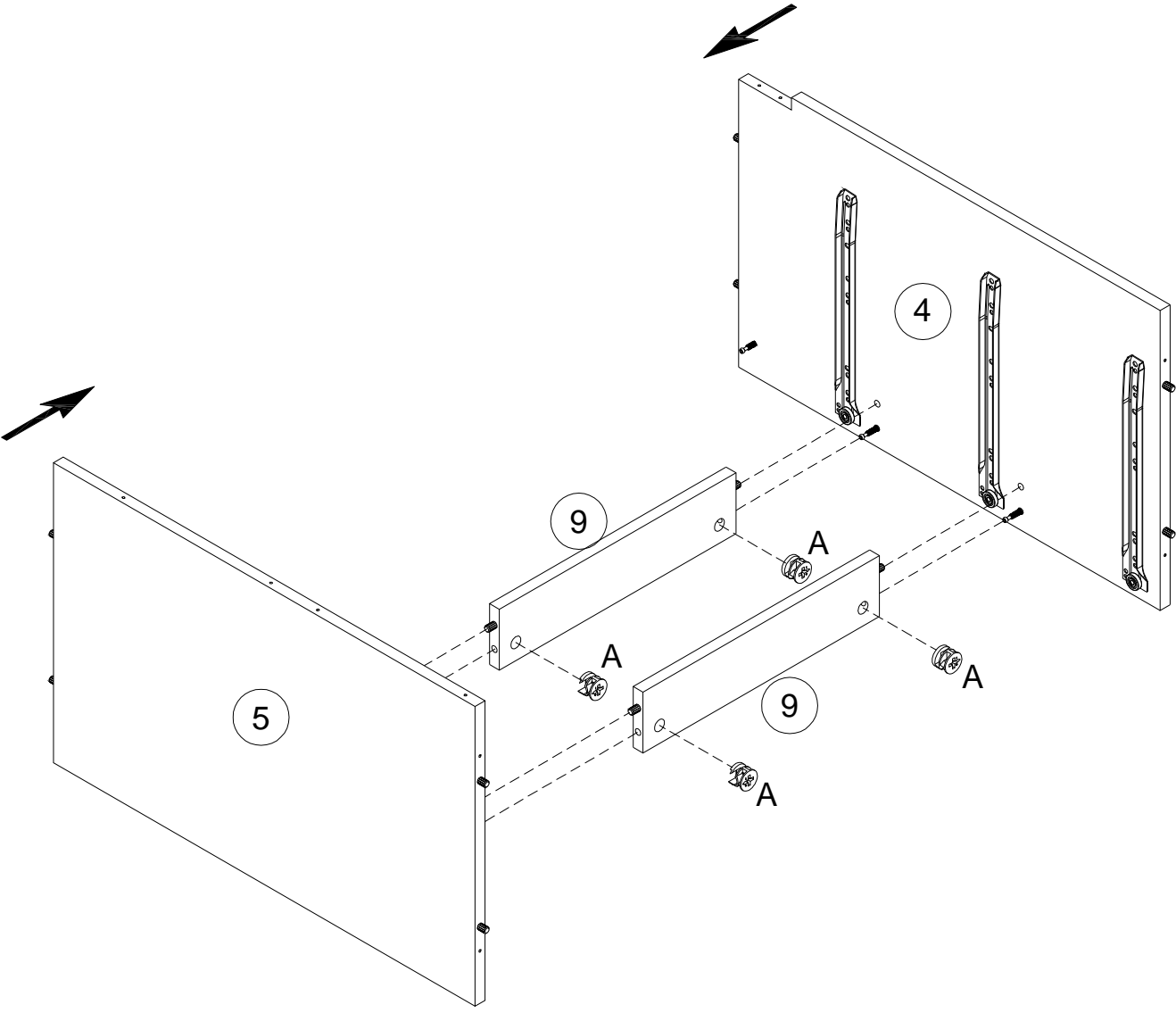

Step 7

A	x 2
	

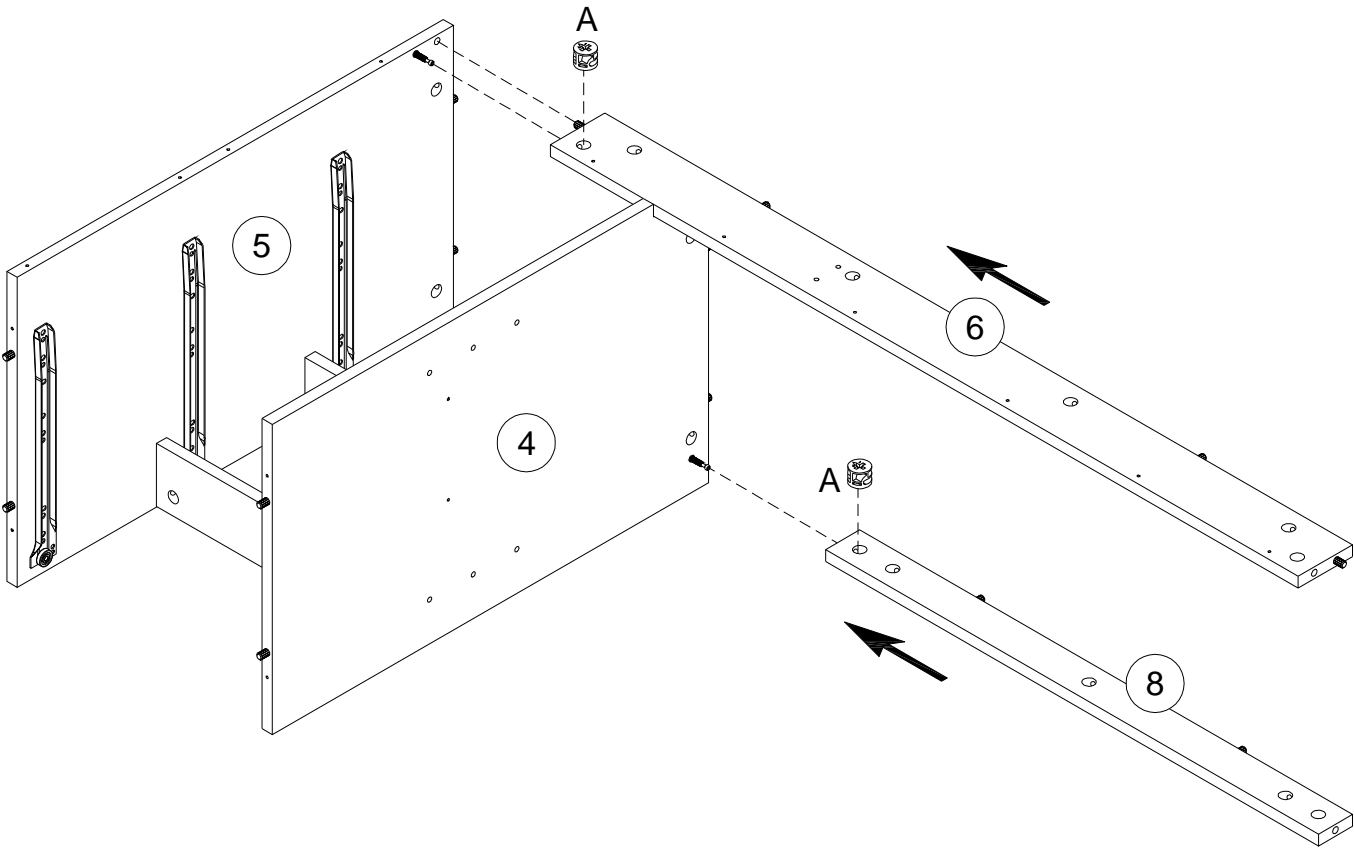

Step 8

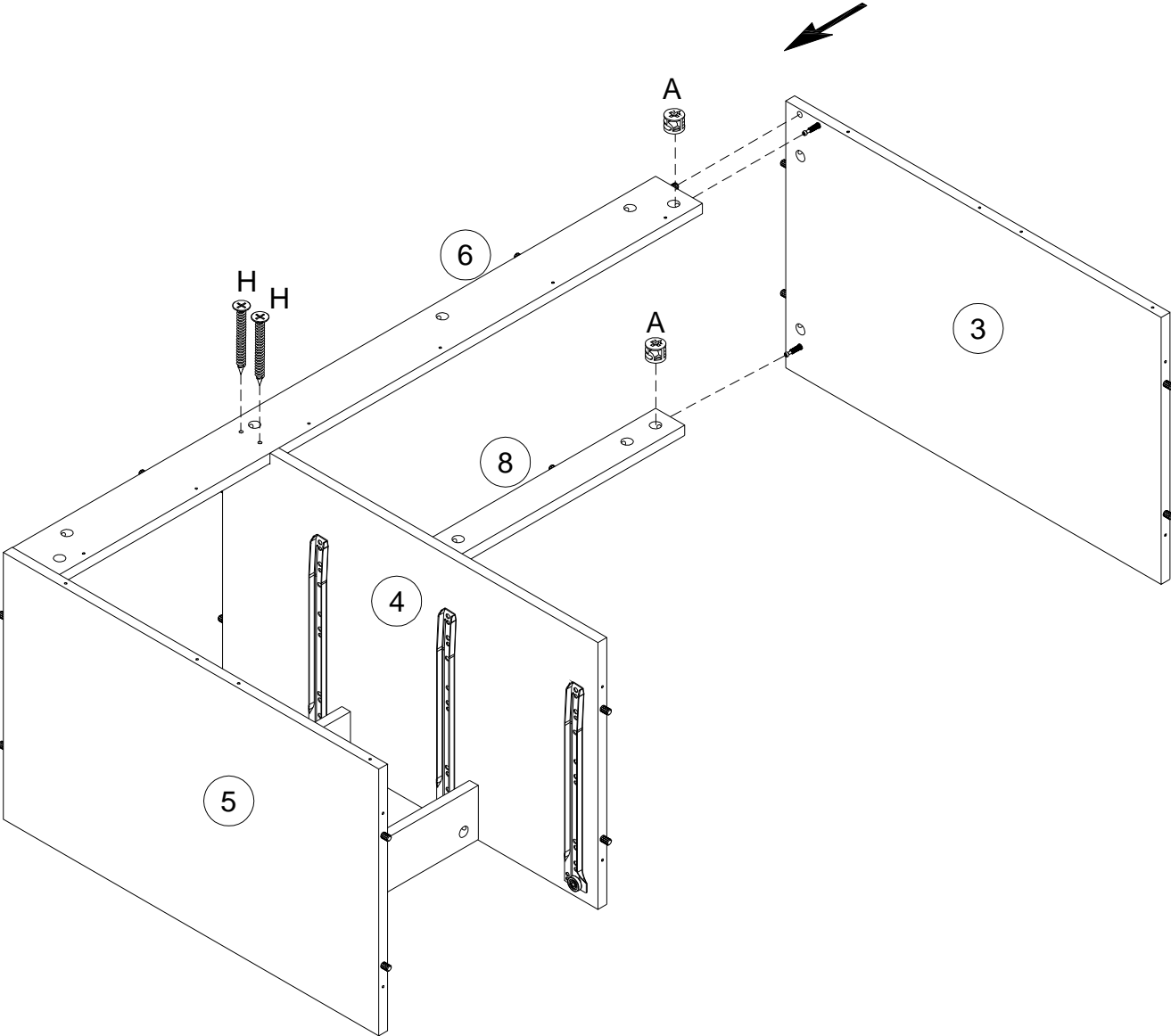
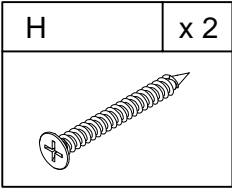
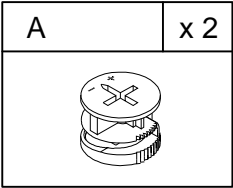

Step 9

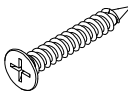
G	x 20
	

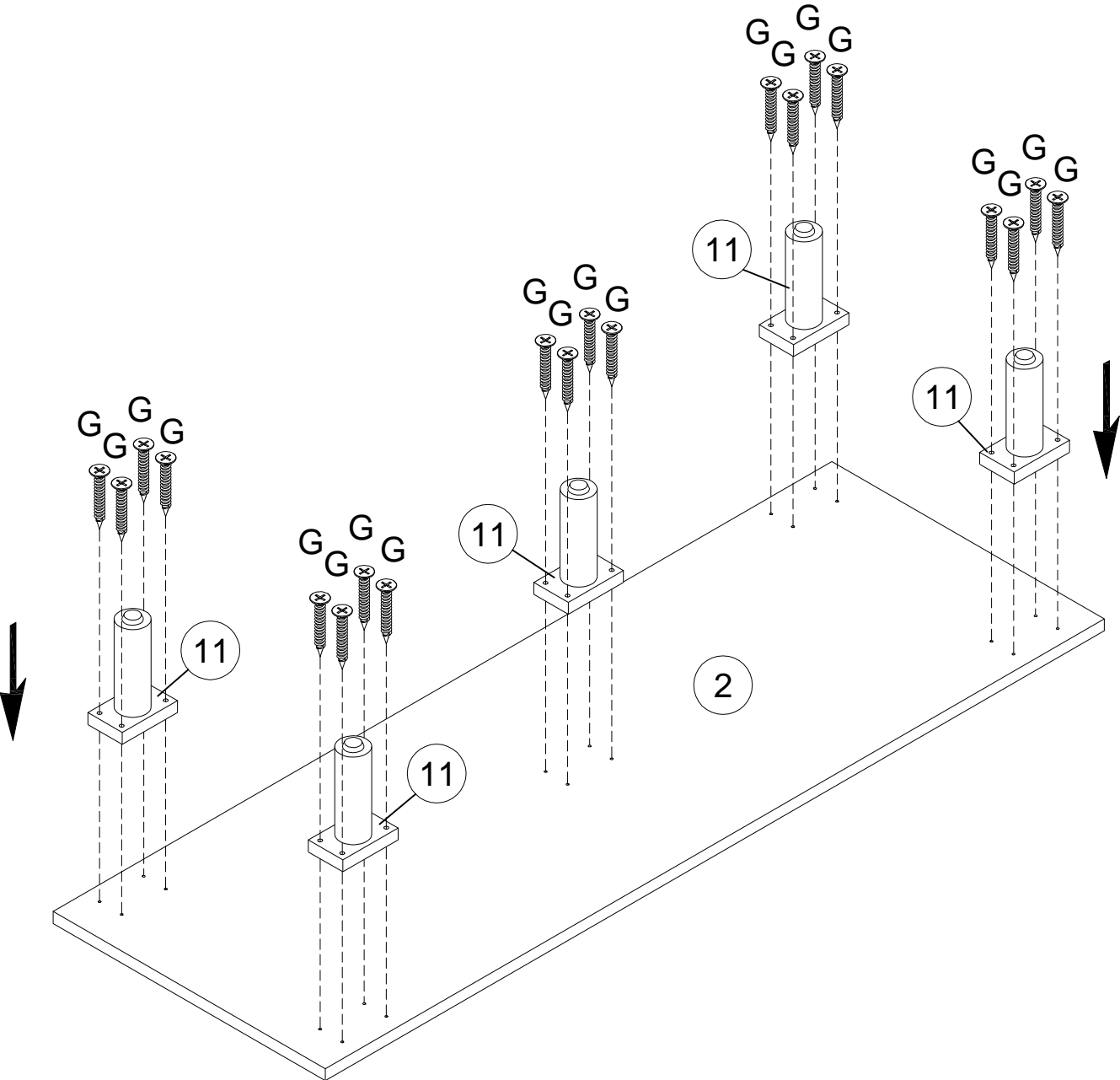

Step 10

1	x 6
	

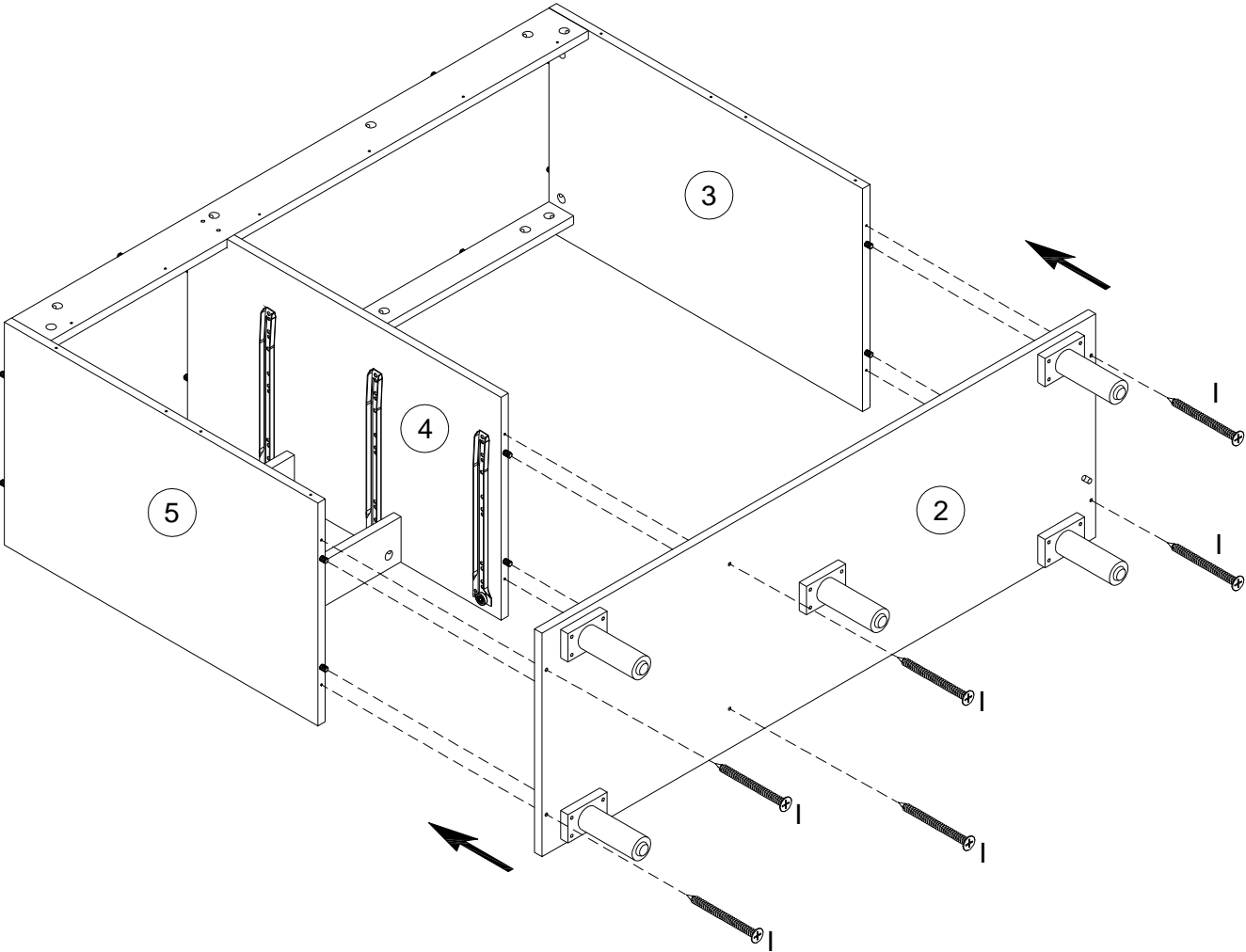

Step 11

A	x 13
	

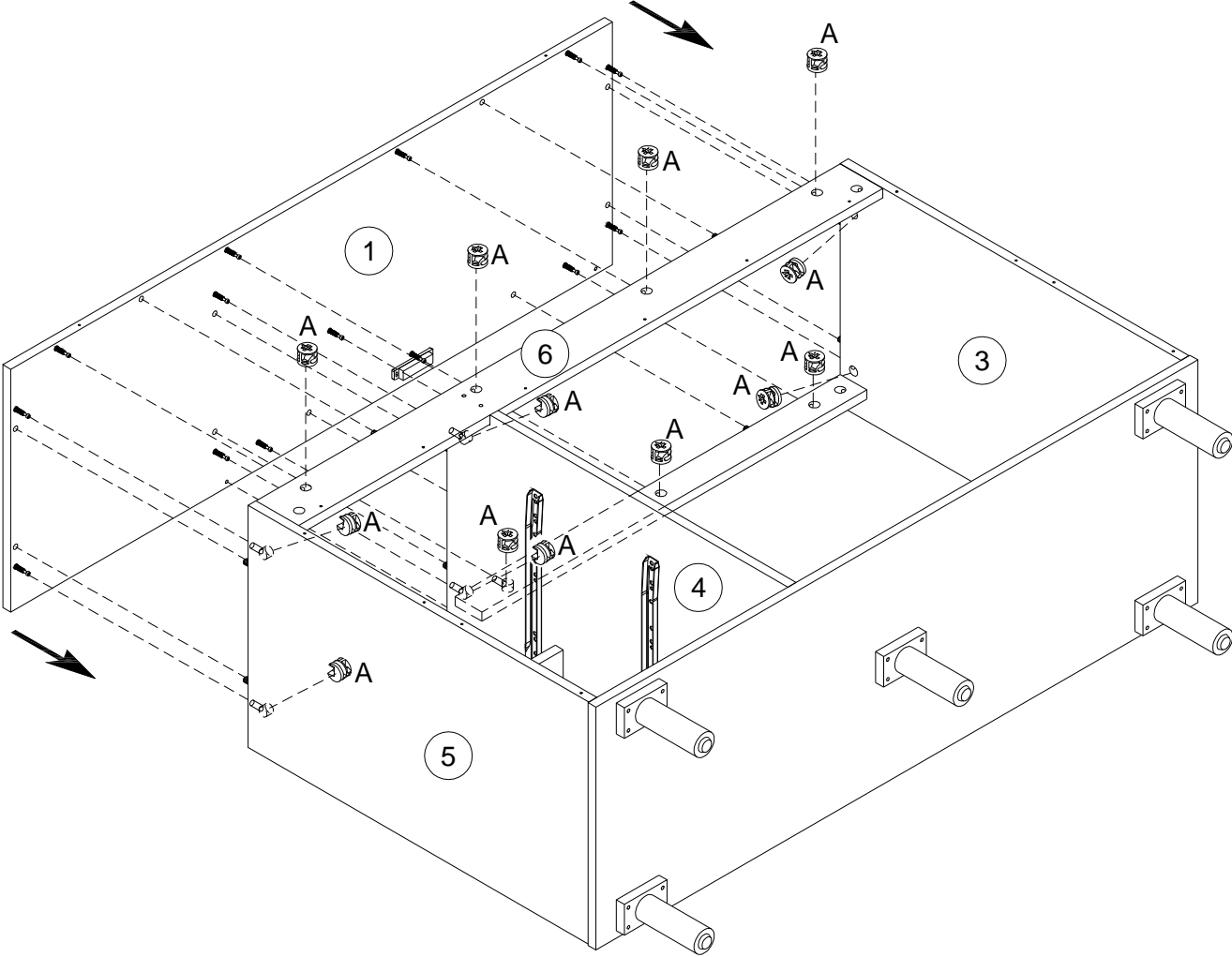

Step 12

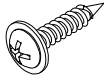
M	x 22
	

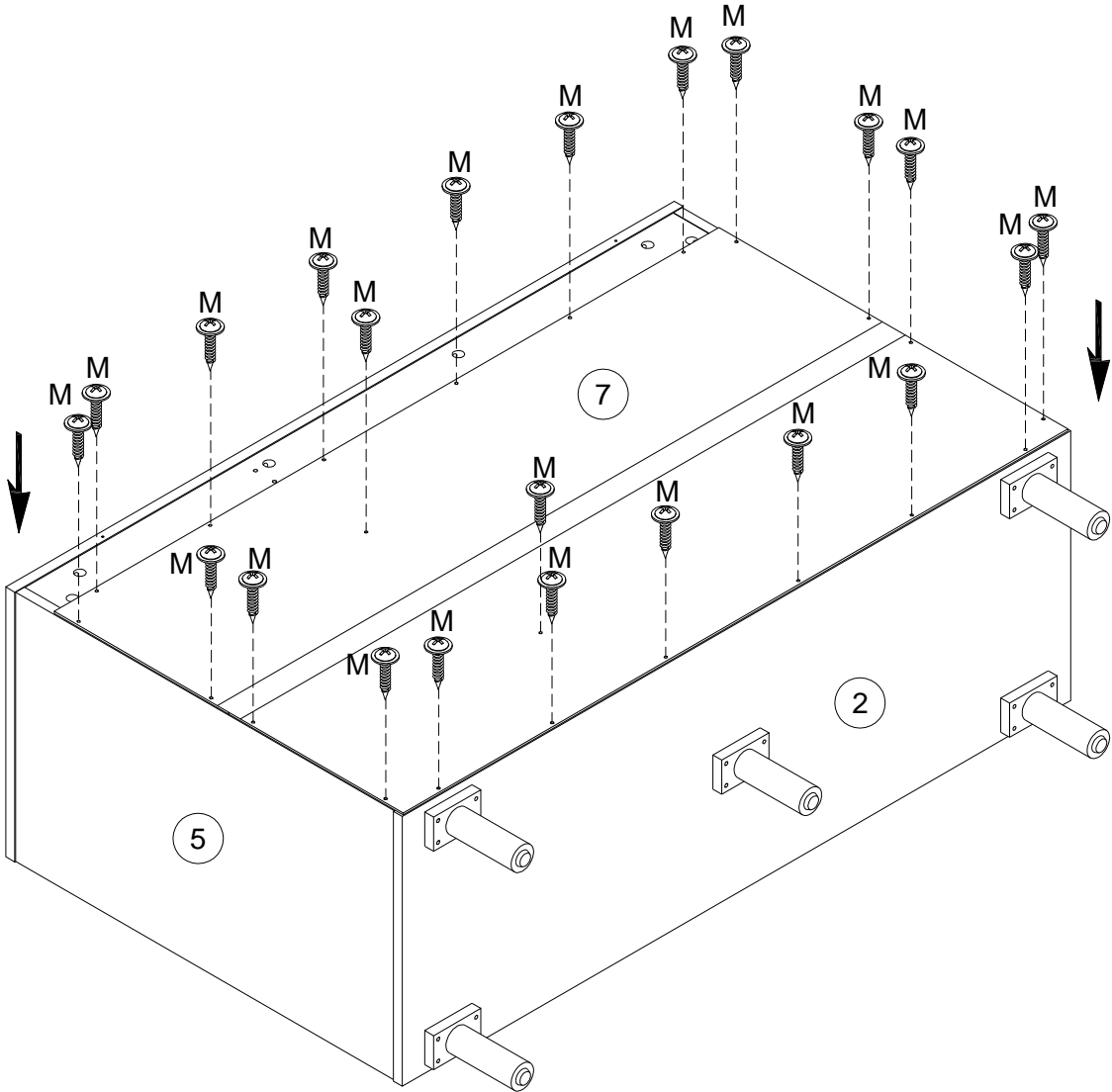

Step 13

B	x 12

H	x 12

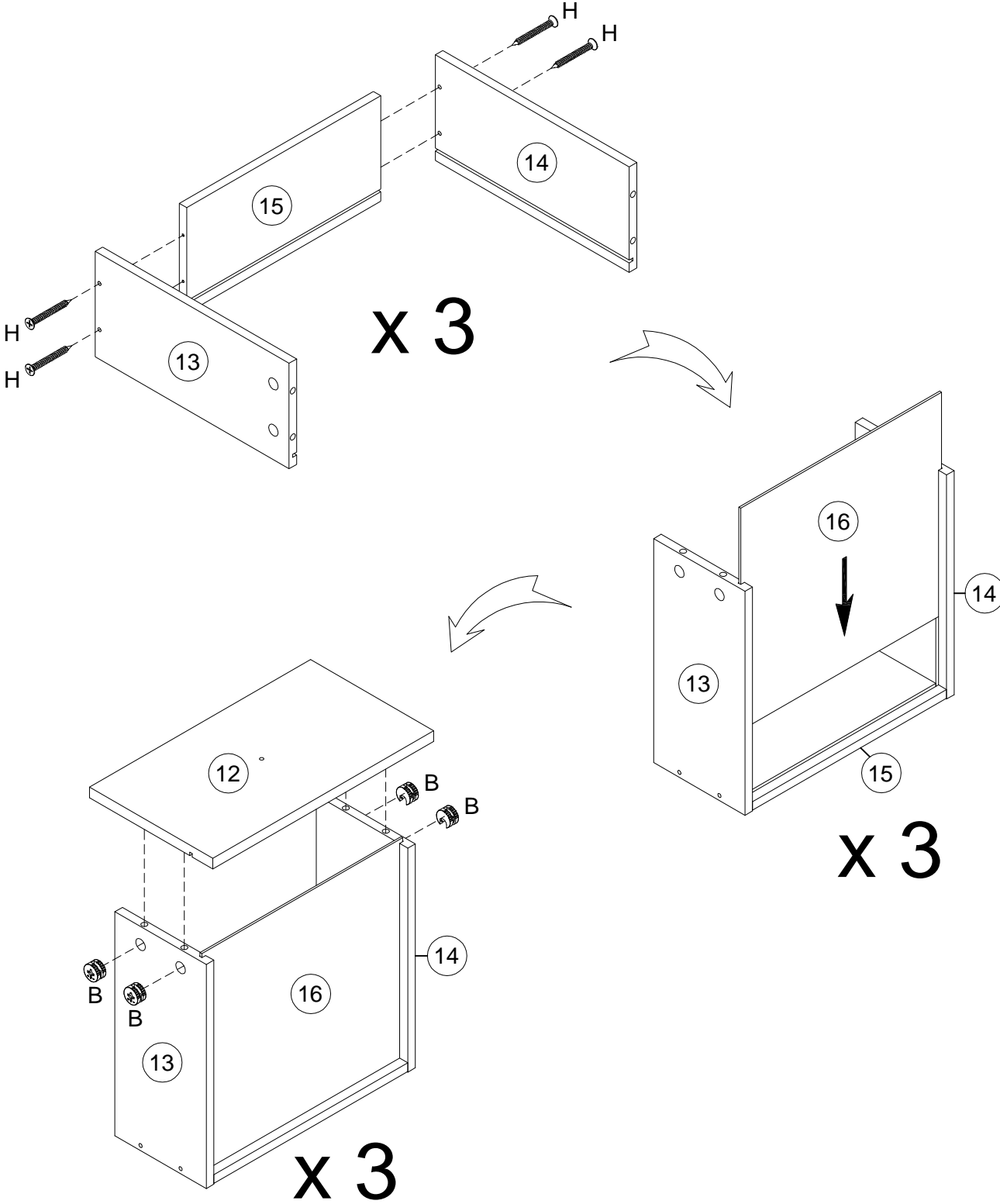

Step 14

L	x 18
	

P	x 3
 DR	

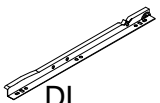
P	x 3
 DL	

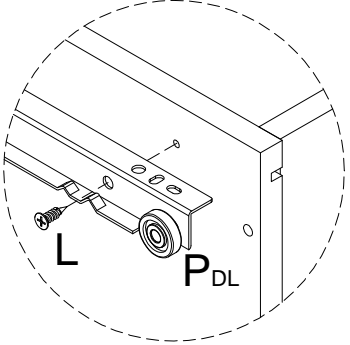
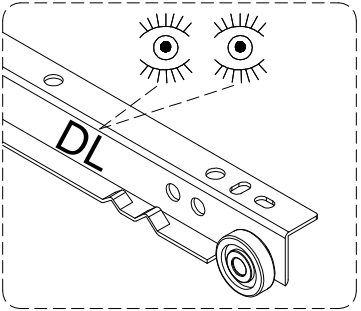
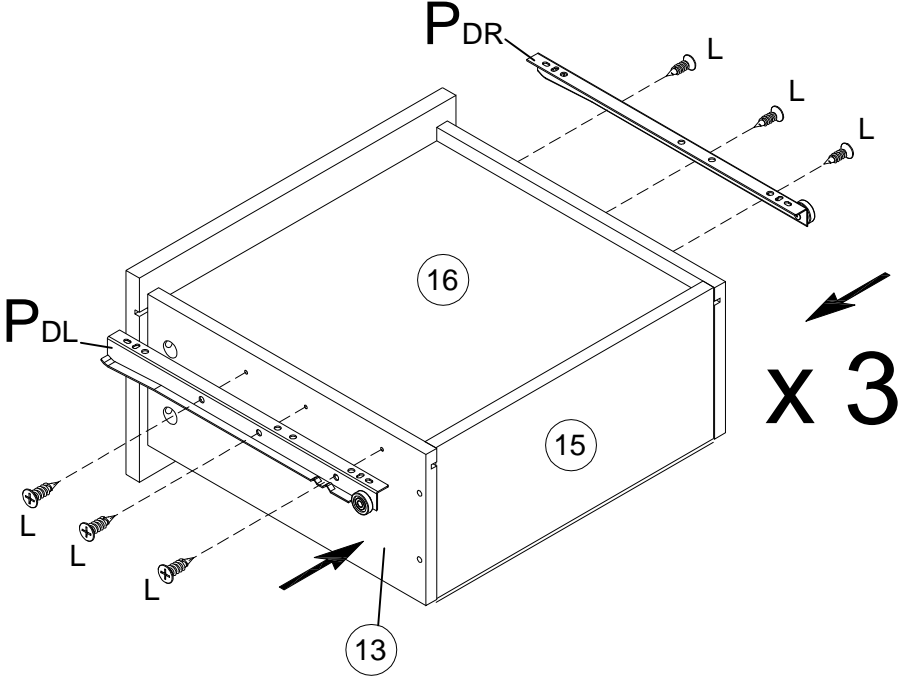
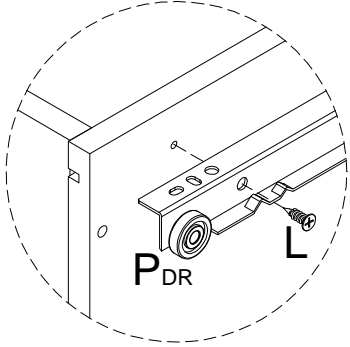
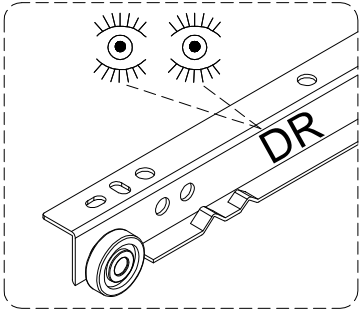

Step 15

F	x 3
	

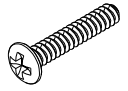
J	x 3
	

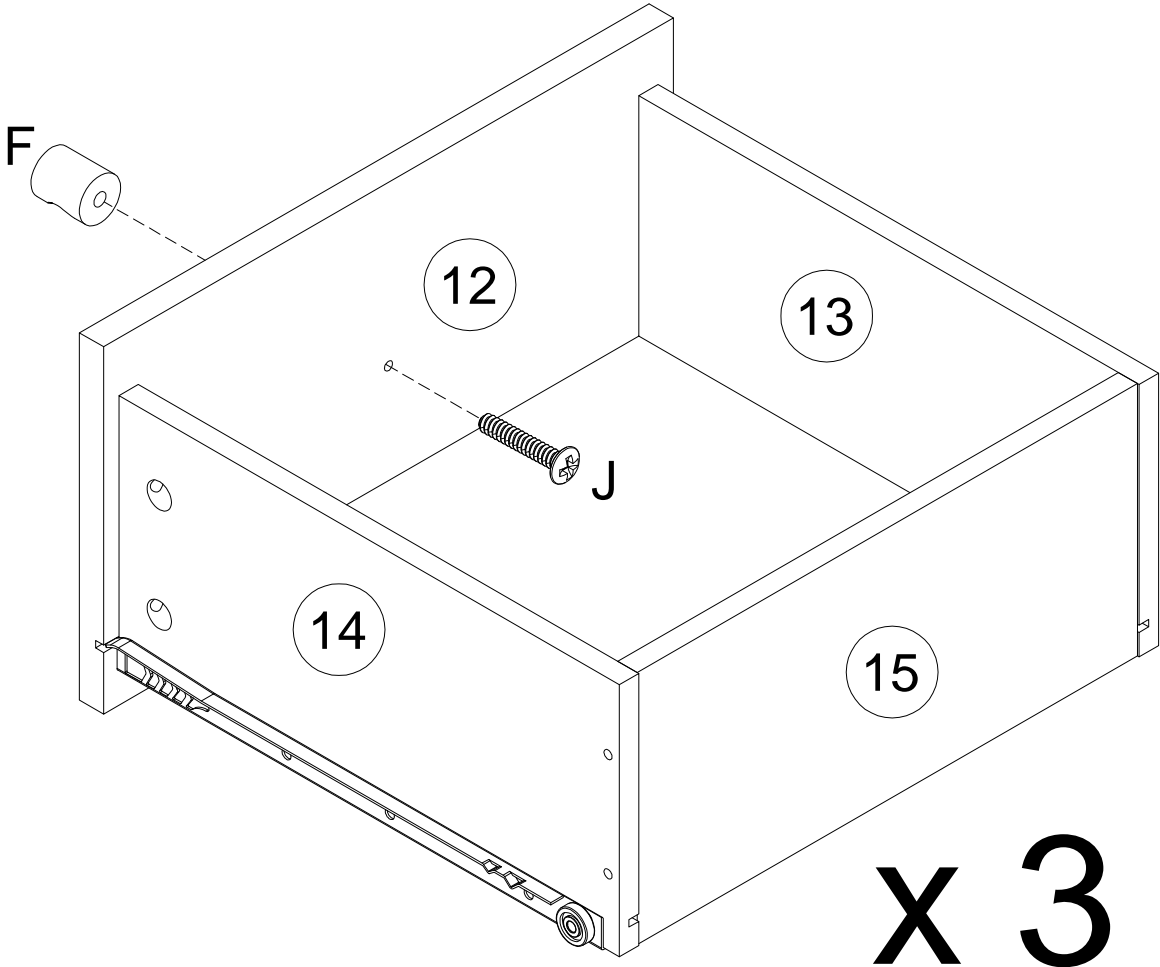

Step 16

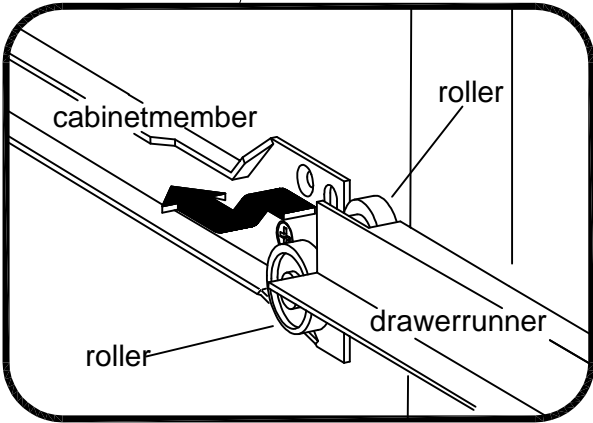
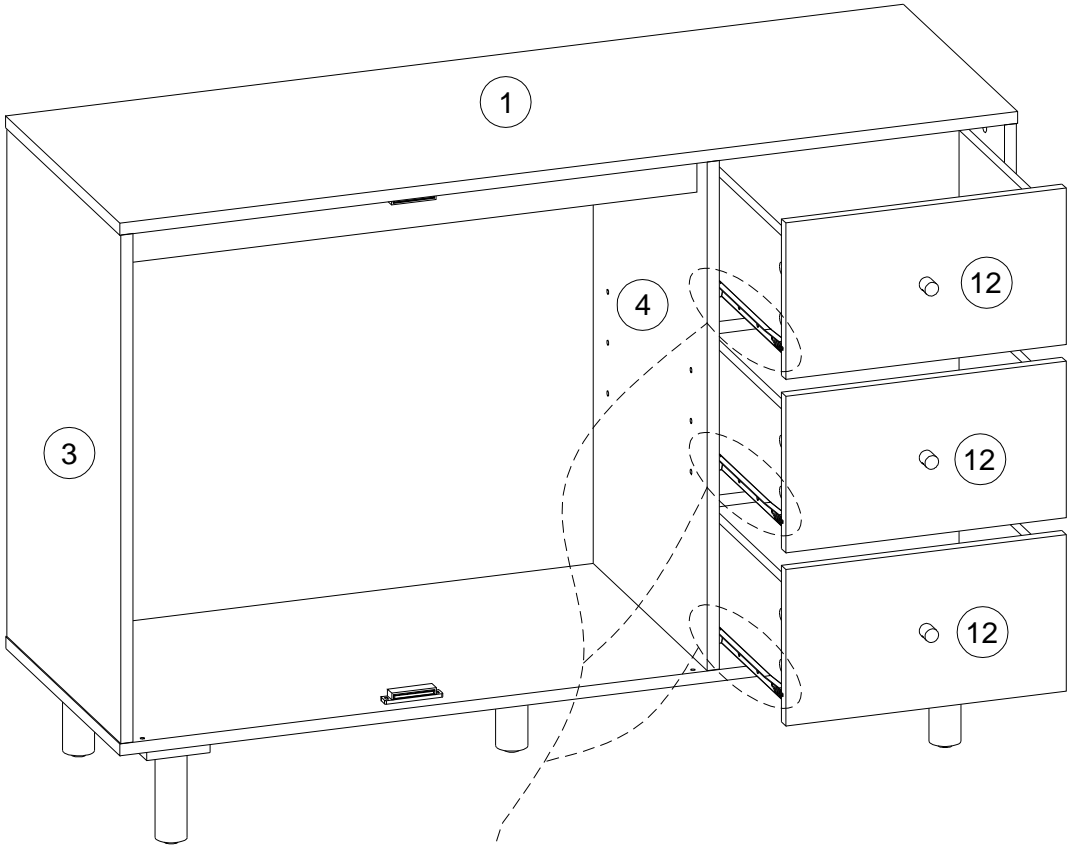

Step 17

N	x 4
	

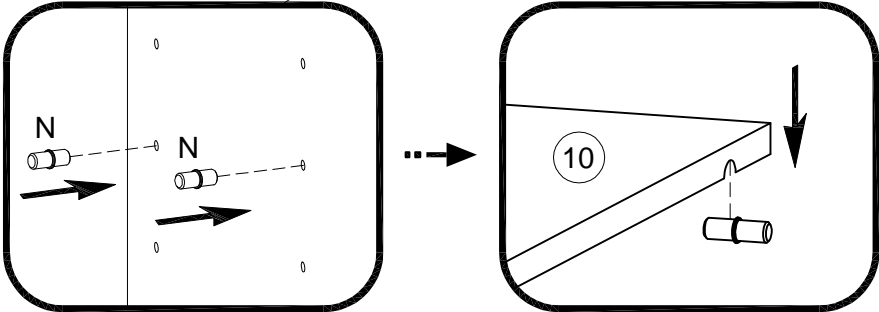
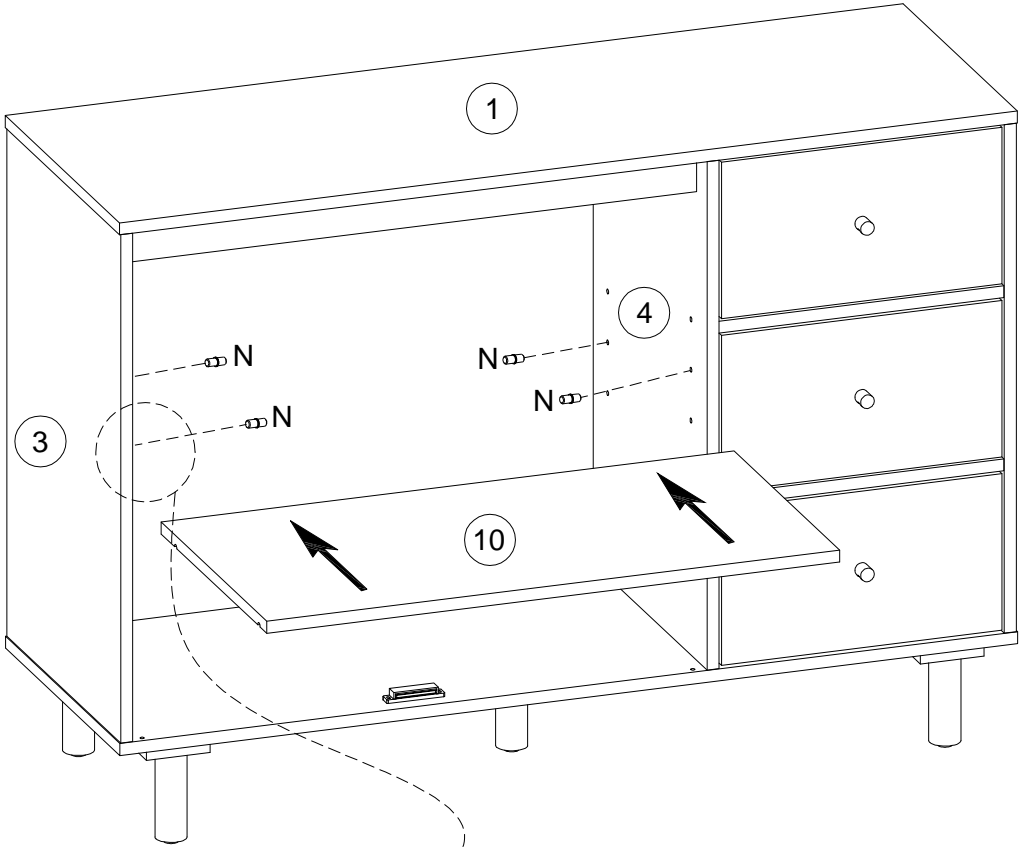

Step 18

E	x 2
	

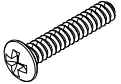
J	x 4
	

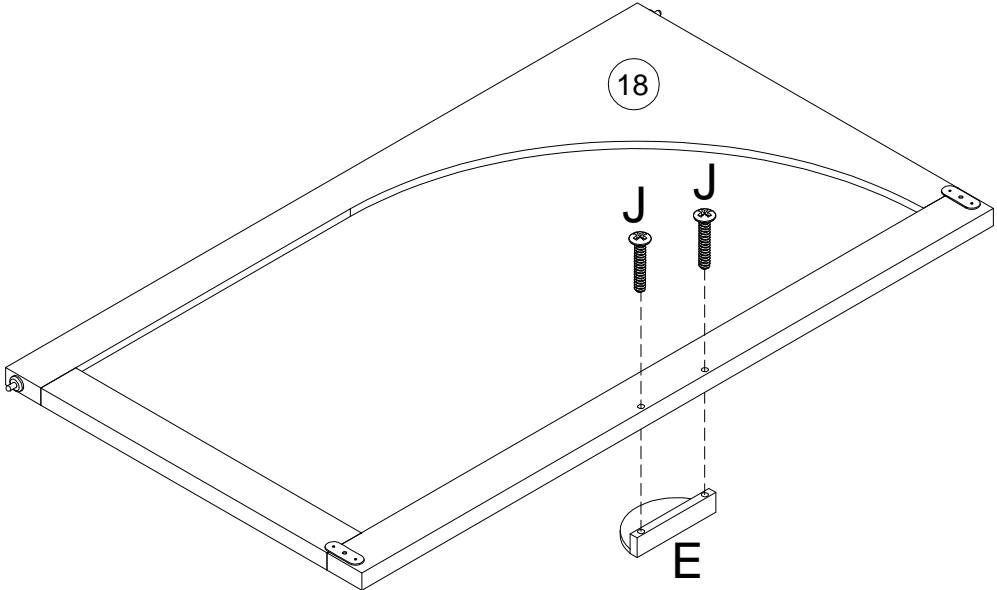
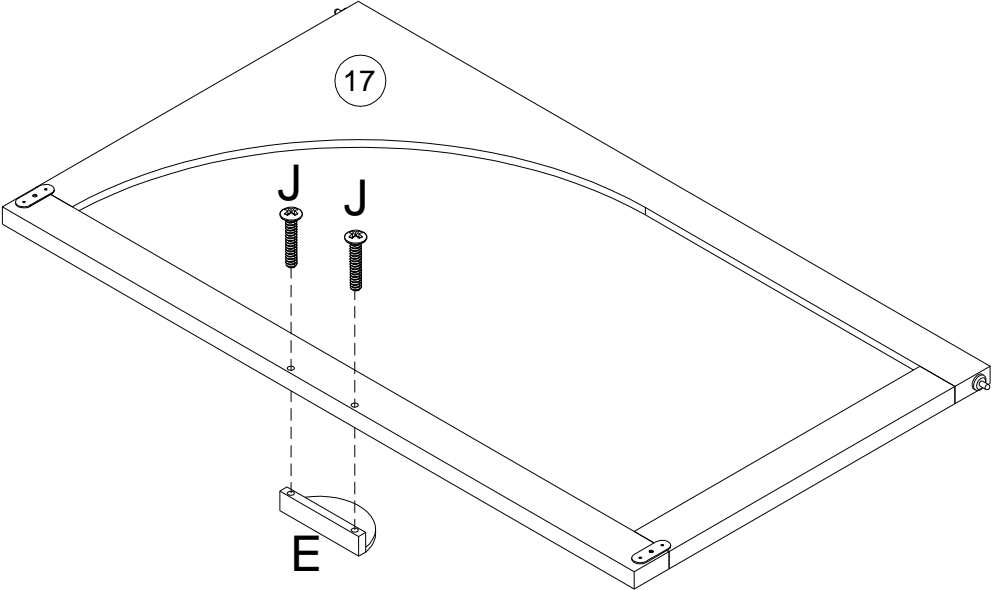

Step 19

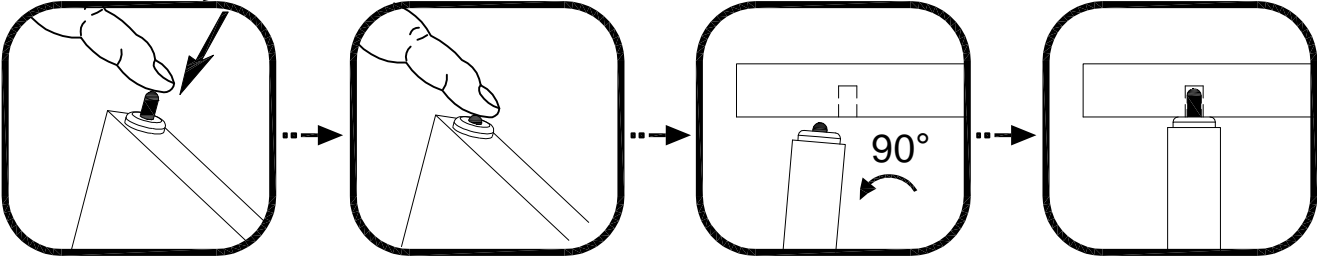
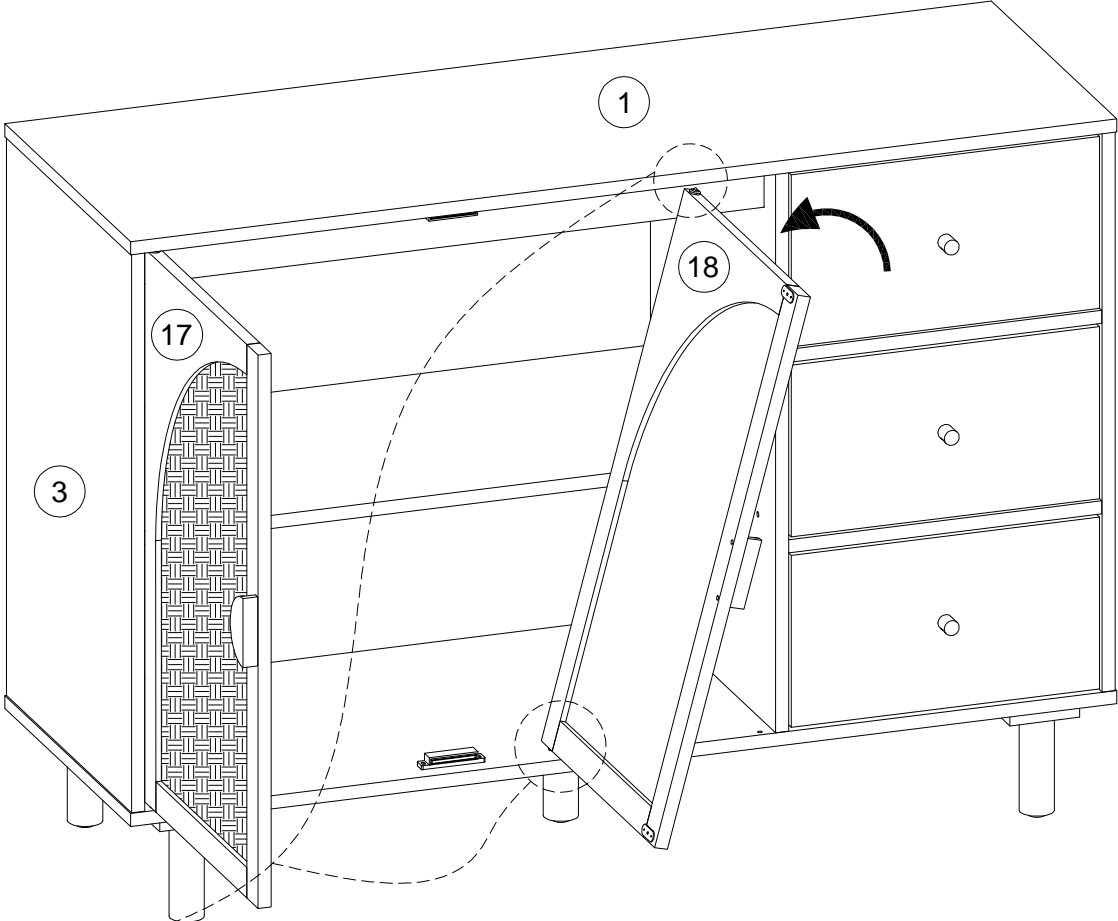

Step 20

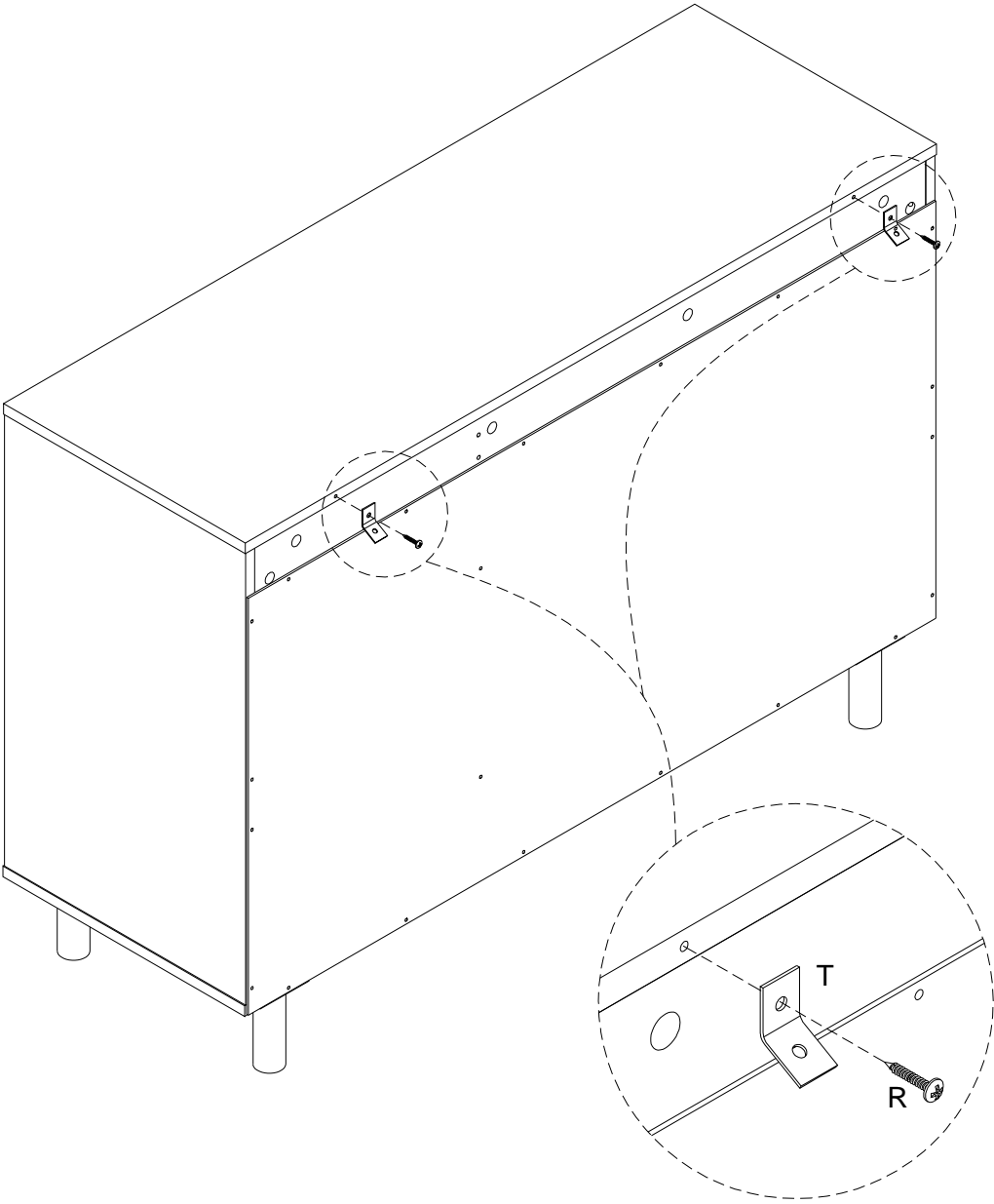
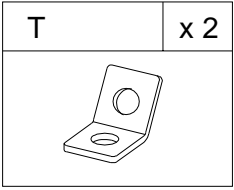
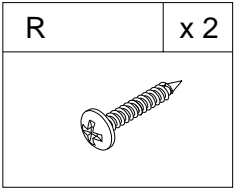

Step 21

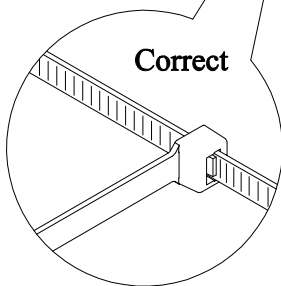
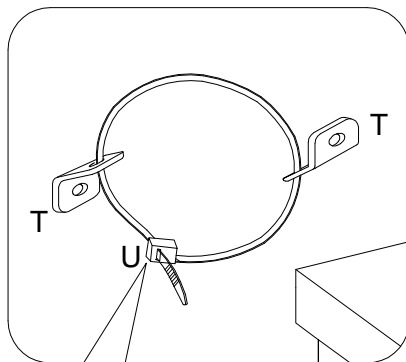
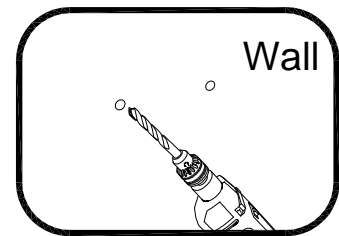
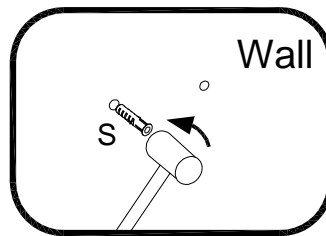
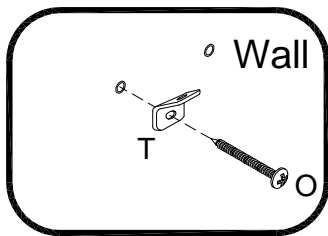
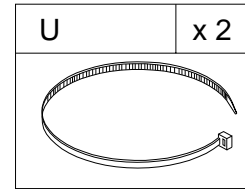
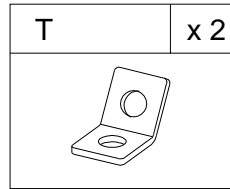
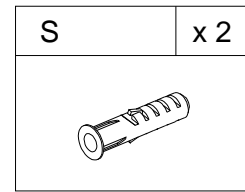
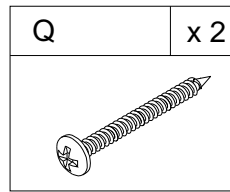

Pull to verify lock

