

# ASSEMBLY INSTRUCTION

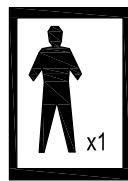

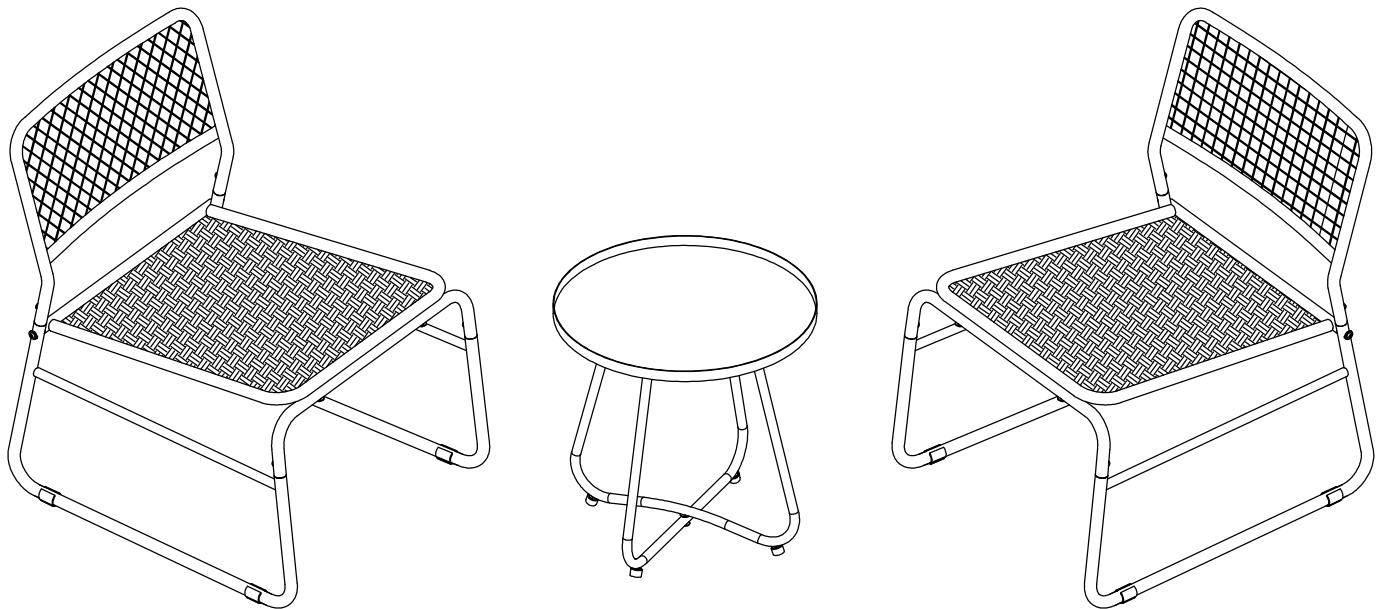



## SOFA SET - WS327.3

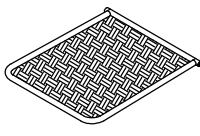
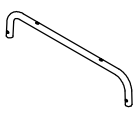
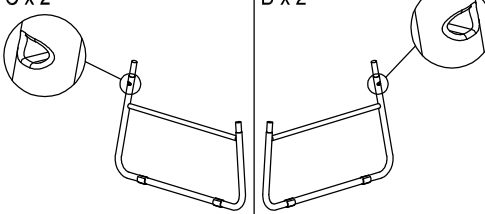
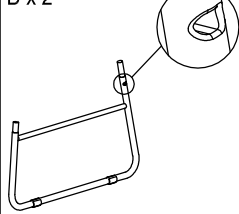
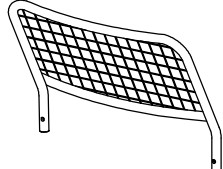
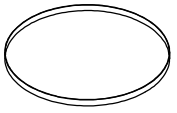
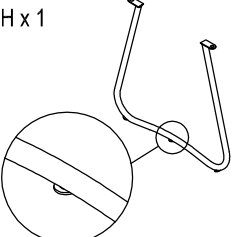
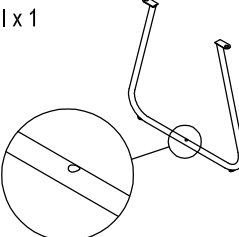

### Notice:

1. Tighten all screws by 50% before fixing. It is recommended to use an Allen wrench instead of an electric drill.
2. Place the item on a flat surface to adjust and ensure stability.
3. Gradually tighten all screws with tools.
4. If screws do not align with holes during assembly, please loosen all other screws by 50% and continue the assembly process.
5. If the item is not stable, please loosen all screws, adjust it on a flat surface, and then tighten all screws again.
6. Note: If one or more screws are fully tightened during assembly, there is a chance that others will not align with the holes. Additionally, all holes are designed to be relatively larger to provide more space for adjusting the screws.

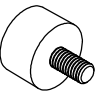
# I - PARTS AND HARDWARE

<p>A x 2</p> 	<p>B x 2</p> 	<p>C x 2</p> 	<p>D x 2</p> 	<p>E x 2</p> 	<p>G x 1</p> 
<p>H x 1</p> 	<p>I x 1</p> 	<p>J x 9</p>  <p>M6x30</p>	<p>K x 12</p>  <p>M6x10</p>	<p>L x 13</p>  <p>D16/7 x1</p>	<p>M x 4</p>  <p>M6x25/D20</p>
<p>N x 1</p> 					

## II - PRODUCT ASSEMBLY: TABLE

"DO NOT tighten the screws until all of parts set into correct position"

**STEP 1:**

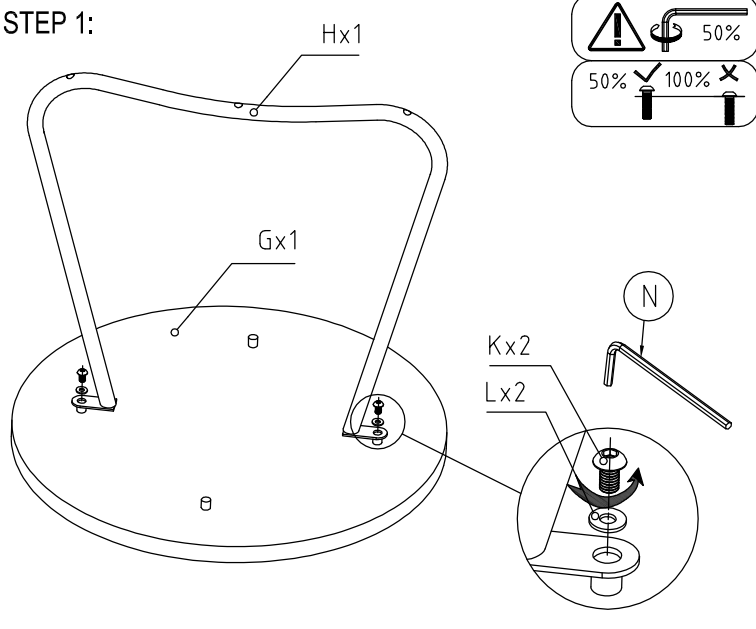

**STEP 2:**

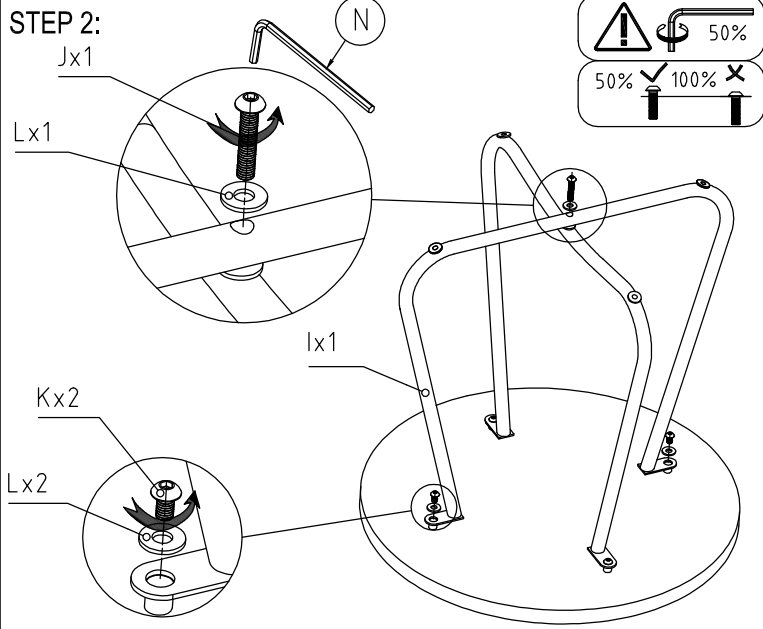

**STEP 3:**

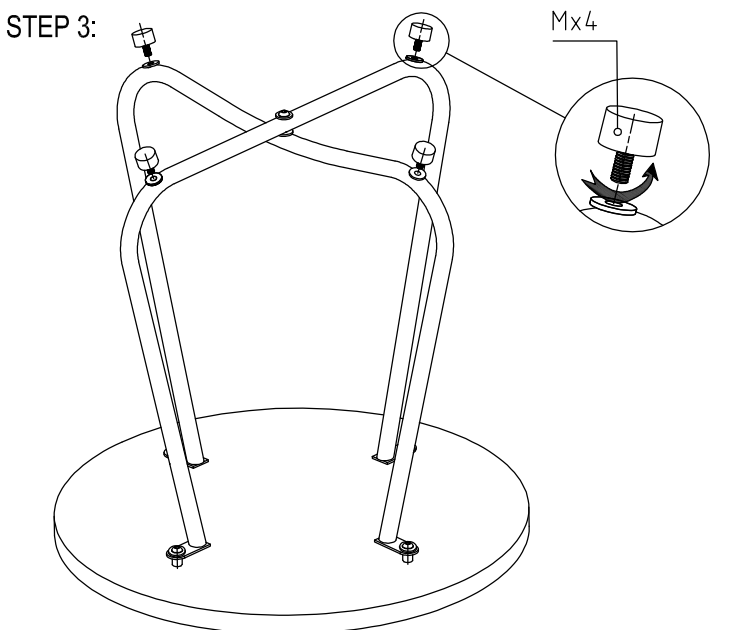

**STEP 4:**

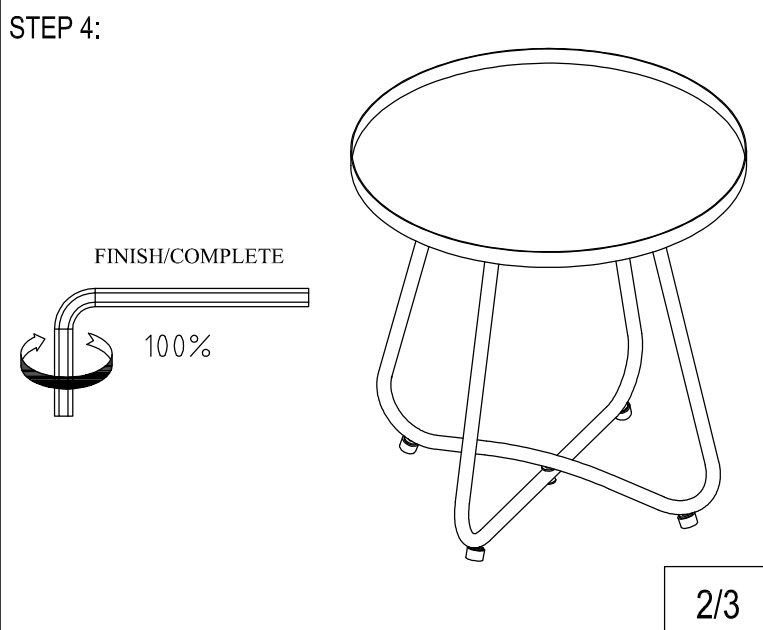

FINISH/COMPLETE

100%

STEP 1:

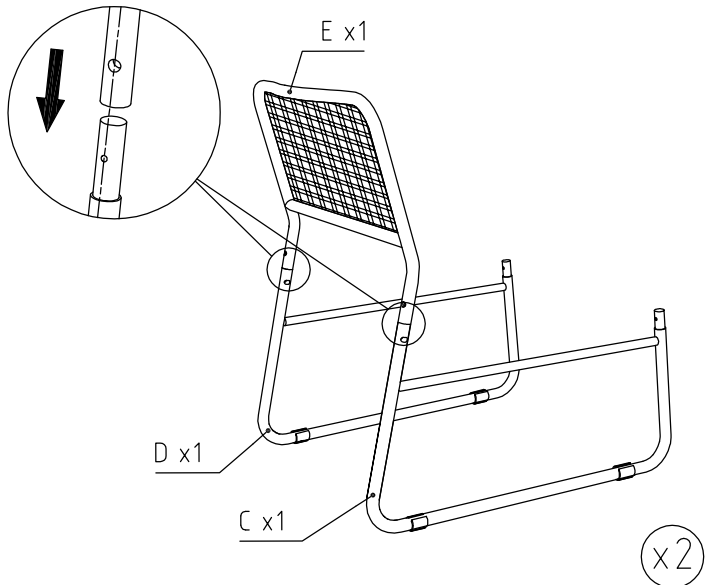

STEP 2:

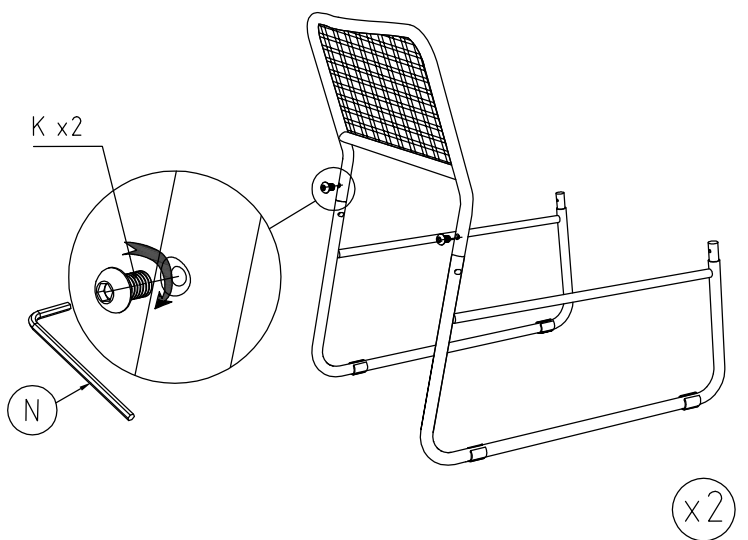

STEP 3:

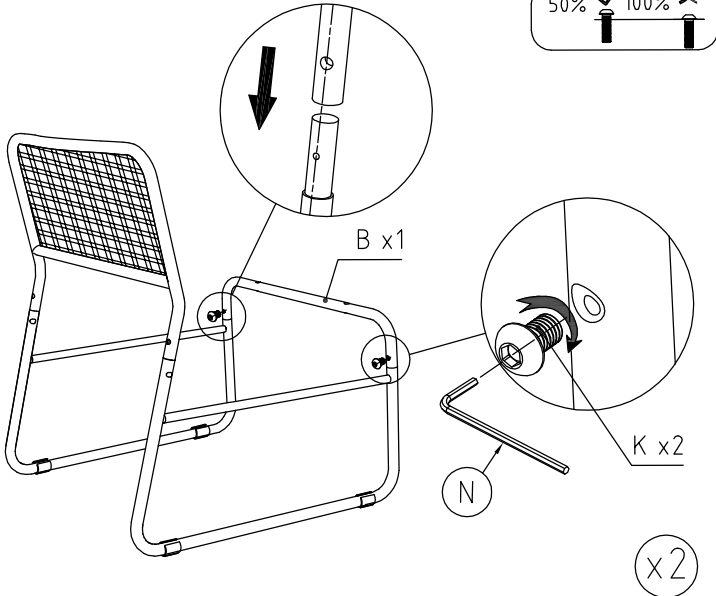

STEP 4:

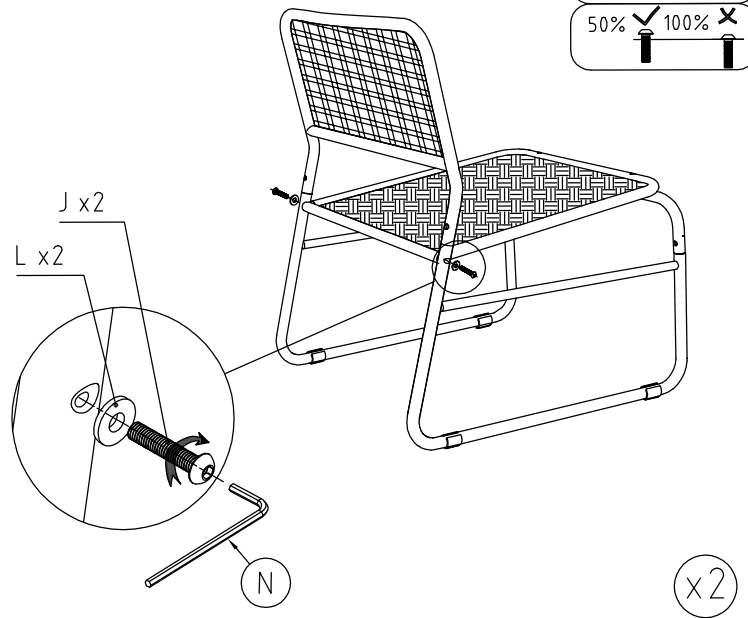

STEP 5:

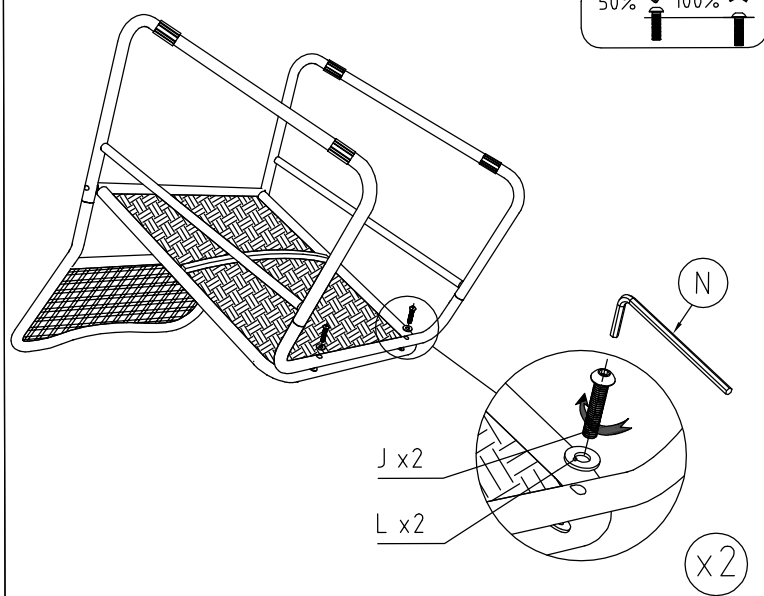

STEP 6:

