

ASSEMBLY INSTRUCTIONS  
Item No : W1596102408  
Description : CONSOLE TABLE

Thank you for purchasing this quality product . Be sure to check all packing material carefully for small part that may have come loose inside the carton during shipment .

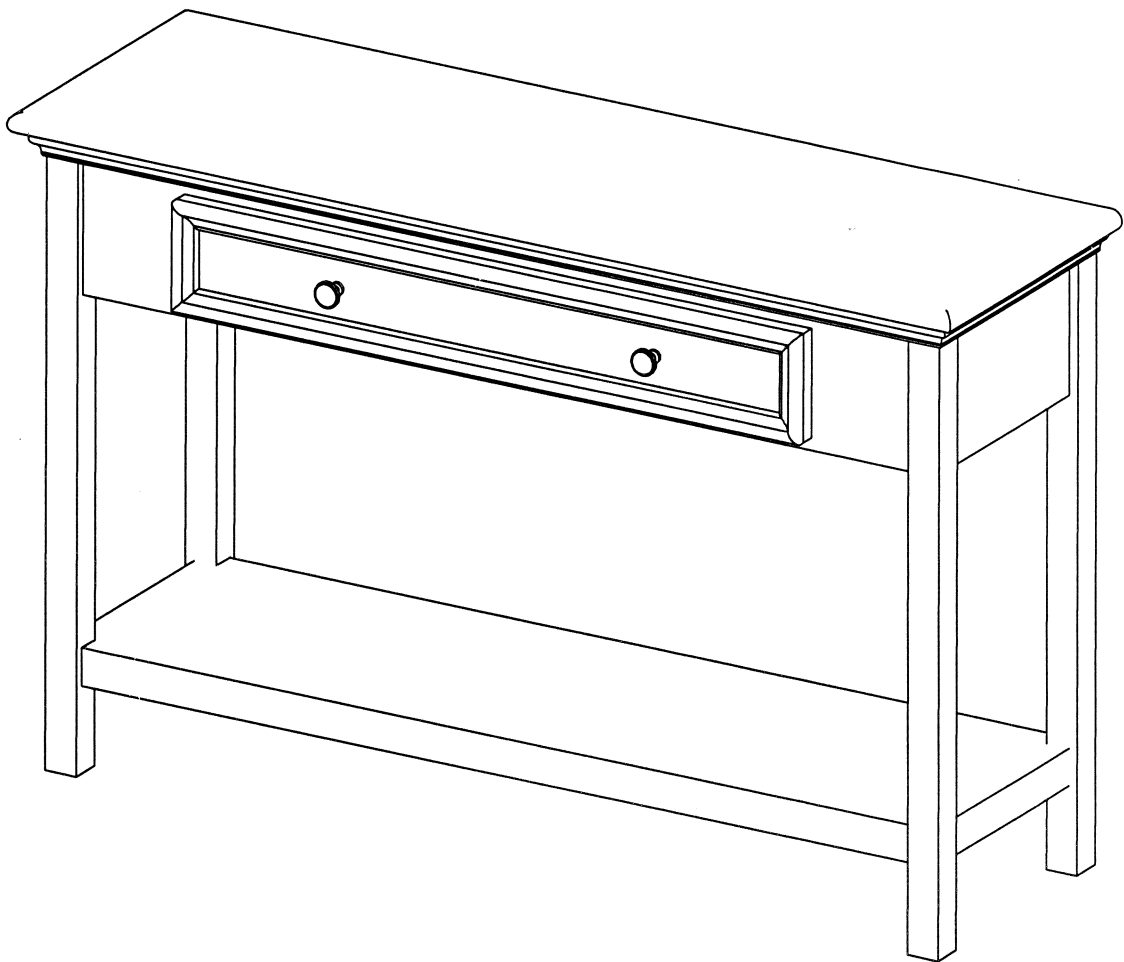



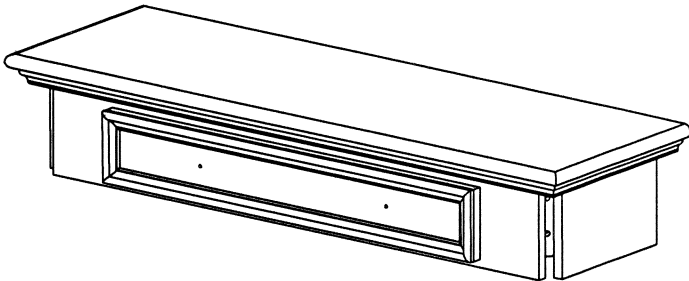
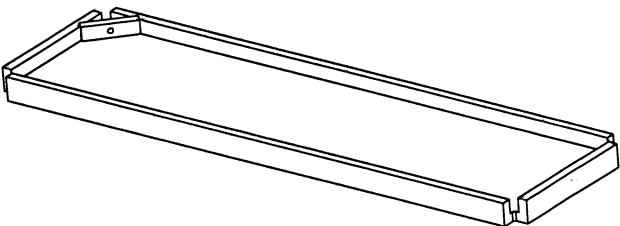
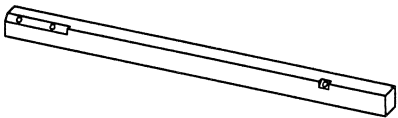

**ASSEMBLY INSTRUCTIONS**  
 Item No : W1596102408  
 Description : CONSOLE TABLE

Thank you for purchasing this quality product . Be sure to check all packing material carefully for small part that may have come loose inside the carton during shipment .

**PART LIST:**

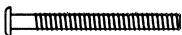
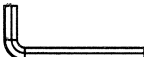
No.	Description	Sketch	Quantity
A	Table Top		1 Unit
B	Table Shelf		1 Unit
C	Table Legs		4 Pcs

**HARDWARE LIST**





No.	Description	Sketch	Size	Quantity
1	JCBC		M6x70	12 Pcs
2	Allen Key		M4	1 Pc
3	Flat Washer			12 Pcs
4	Spring Washer			12 Pcs
5	Handle			2 Pcs
6	Handle Screw		M4x22	2 Pcs

**ASSEMBLY INSTRUCTIONS**  
 Item No : W1596102408  
 Description : CONSOLE TABLE

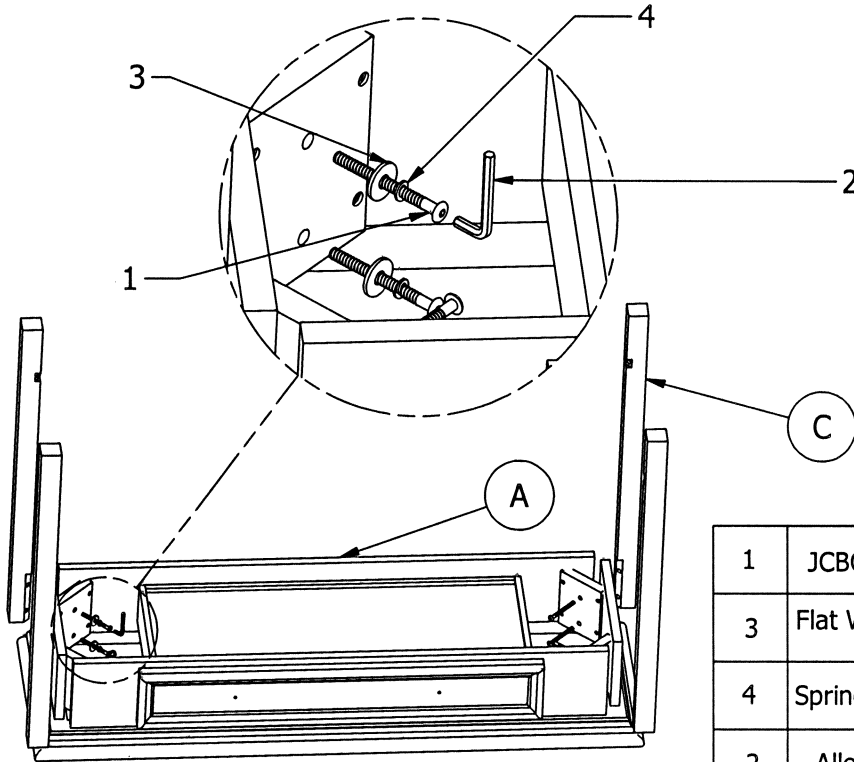
Thank you for purchasing this quality product . Be sure to check all packing material carefully for small part that may have come loose inside the carton during shipment .





**Step 1:** Lay the Table Top (A) on a flat CLEAN surface, assembly the Table Legs (C) to the corner of the table top, hardware use is JCBC screw (2), Spring Washer (6) & Flat Washer (3). Tighten the screw with Allen key (7).

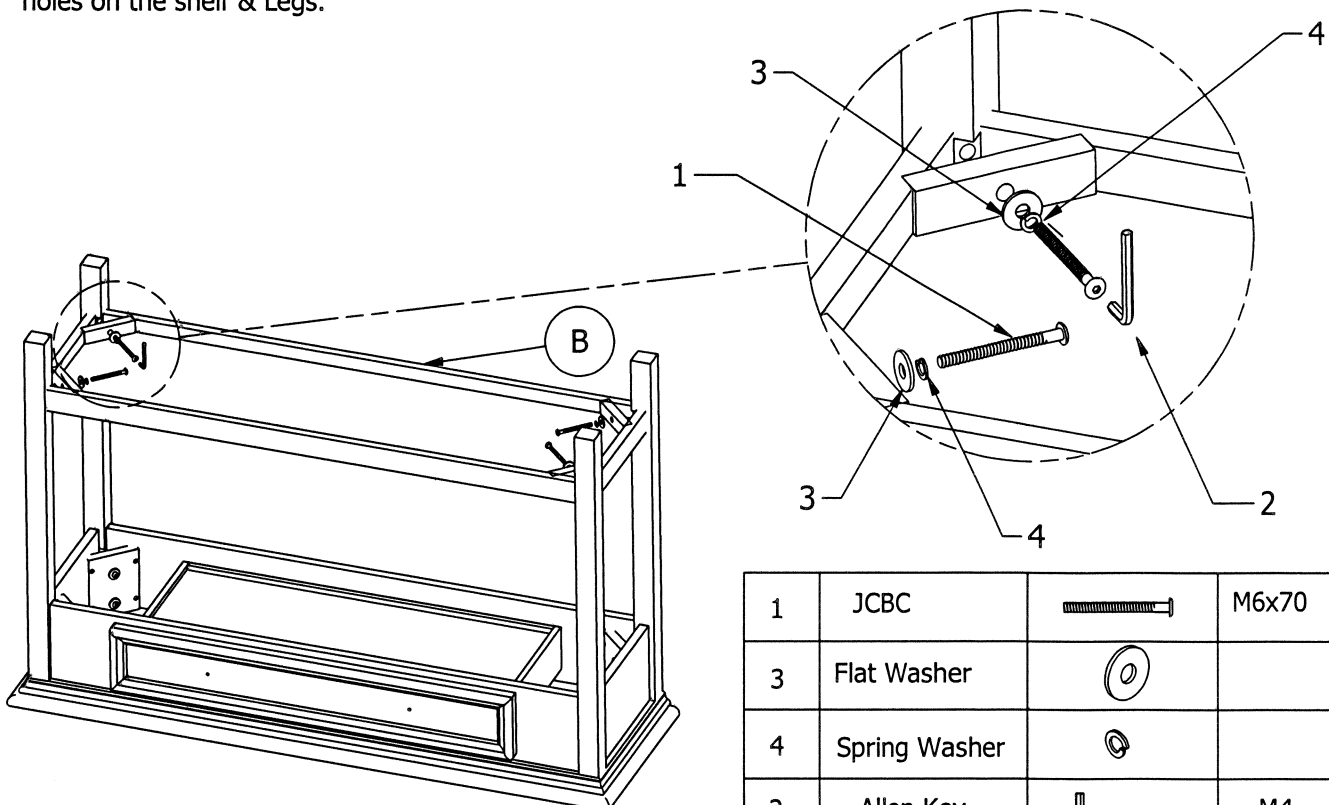

1	JCBC		M6x70	8 Pcs
3	Flat Washer			8 Pcs
4	Spring Washer			8 Pcs
2	Allen Key		M4	1 Pc

**Step 2:** Align the Table Shelf (B) to the Legs pre-drilled holes and screw the attachment with the hardware shown in the image. Arrange as like Flat Washer (3), Spring Washer (6) into the JCBC (2) and tighten with Aleen key (7) to the screw holes on the shelf & Legs.





1	JCBC		M6x70	4 Pcs
3	Flat Washer			4 Pcs
4	Spring Washer			4 Pcs
2	Allen Key		M4	1 Pc

ASSEMBLY INSTRUCTIONS  
Item No : W1596102408  
Description : CONSOLE TABLE

Thank you for purchasing this quality product . Be sure to check all packing material carefully for small part that may have come loose inside the carton during shipment .

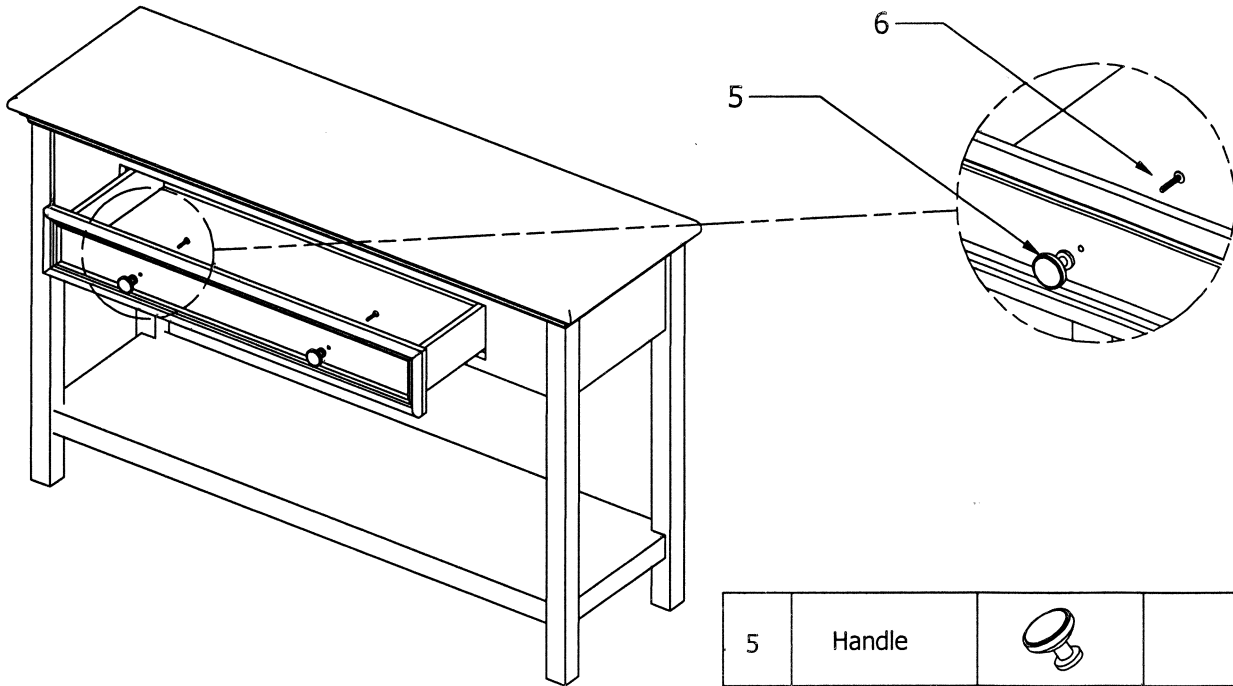
Step 3. Attach the Handle (5) and tighten with Handle Screw (6). You may use screwdriver to help on tightening the connections.



5	Handle			2 Pcs
6	Handle Screw		M4x22	2 Pcs

Finally check on all the connections, makesure it is tighten and the table is ready to use.

