

ASSEMBLY INSTRUCTIONS

Item No : W1596102397

Description : CHEST

Thank you for purchasing this quality product. Be sure to check all packing material carefully for small part that may have come loose inside the carton during shipment.



W1596102397

ASSEMBLY INSTRUCTIONS

Item No : W1596102397

Description : CHEST

Thank you for purchasing this quality product. Be sure to check all packing material carefully for small part that may have come loose inside the carton during shipment .

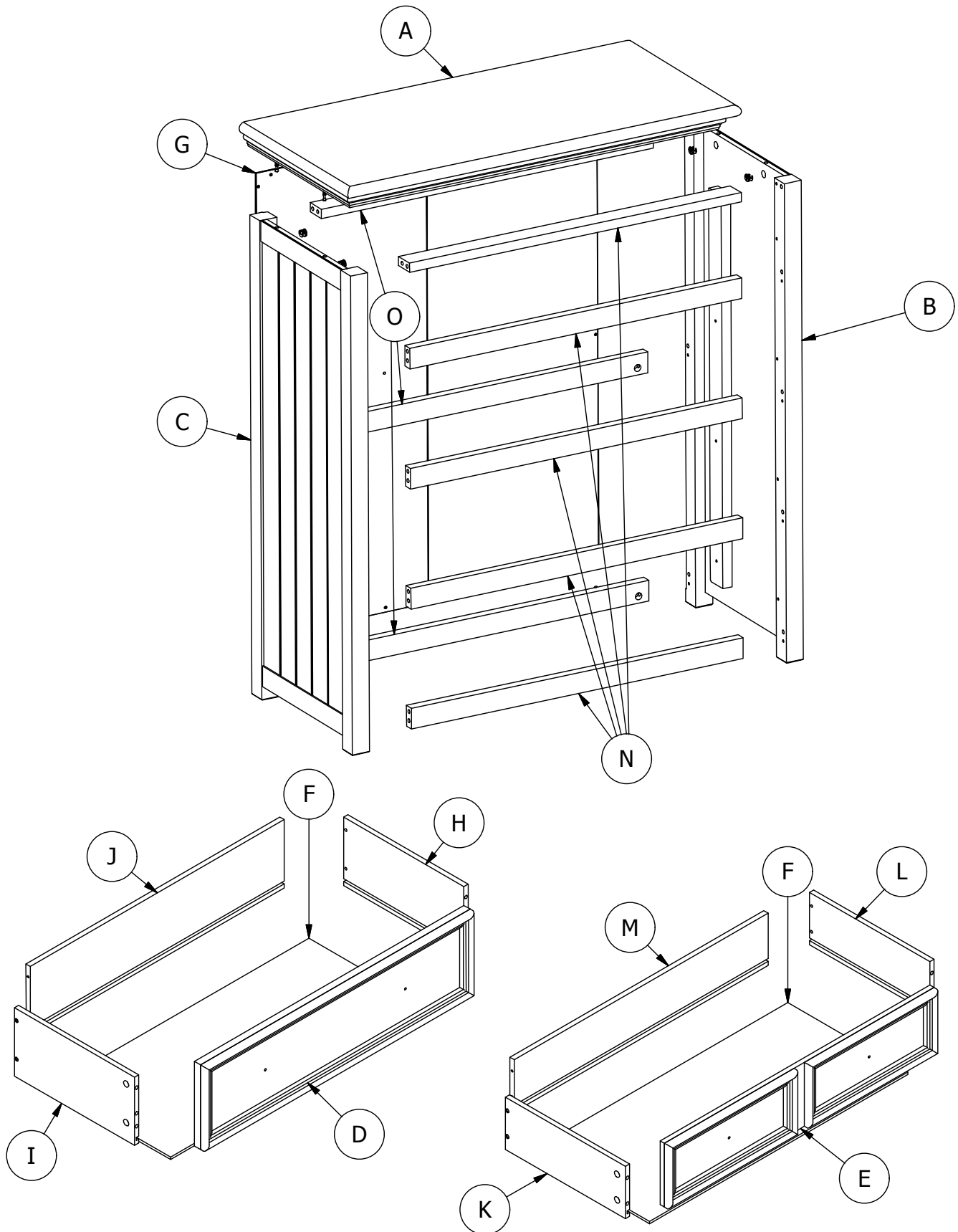



ASSEMBLY INSTRUCTIONS

Item No : W1596102397

Description : CHEST

Thank you for purchasing this quality product . Be sure to check all packing material carefully for small part that may have come loose inside the carton during shipment .

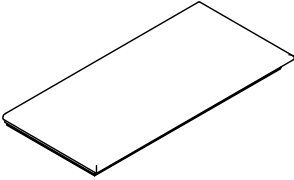
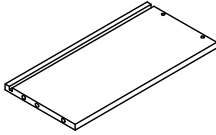
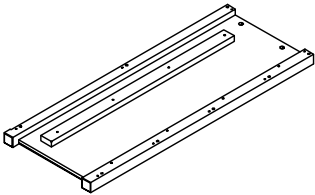
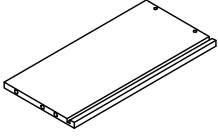
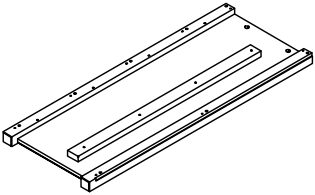
PART LIST:

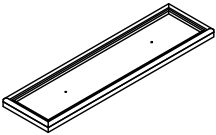
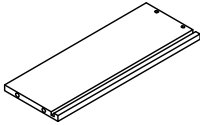
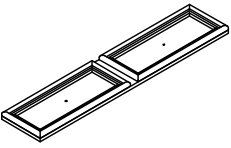
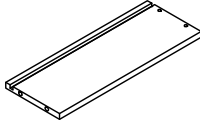
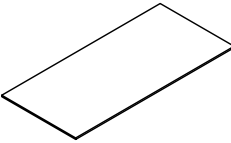
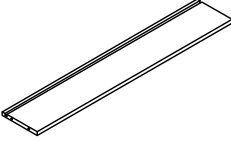
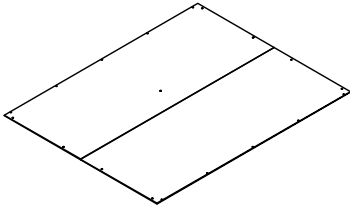
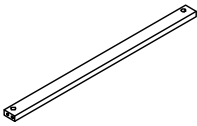
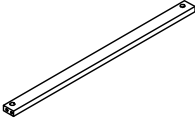
No.	Description	Sketch	Quantity	No.	Description	Sketch	Quantity
A	Table Top		1 Pc	H	Drawer Right Panel		3 Pcs
B	Cabinet Right Panel		1 Pc	I	Drawer Left Panel		3 Pcs
C	Cabinet Left Panel		1 Pc	J	Drawer Back Panel		3 Pcs
D	Drawer Front Panel		3 Pcs	K	Top Drawer Left Panel		1 Pc
E	Top Drawer Front Panel		1 Pc	L	Top Drawer Right Panel		1 Pc
F	Drawer Bottom Board		4 Pcs	M	Top Drawer Back Panel		1 Pc
G	Cabinet Back Panel		1 Pc	N	Front Structure Bone		5 Pcs
				O	Back Structure Bone		3 Pcs







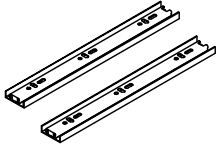

ASSEMBLY INSTRUCTIONS

Item No : W1596102397

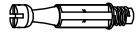
Description : CHEST

Thank you for purchasing this quality product . Be sure to check all packing material carefully for small part that may have come loose inside the carton during shipment .

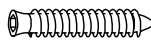
HARDWARE LIST

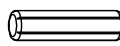
No.	Description	Sketch	Size	Quantity	No.	Description	Sketch	Size	Quantity
1	Drawer Runner Slide		Standard	4 Sets	6	Wooden Handle			8 Pcs
					7	Handle Screw		M4x22	8 Pcs
2	Dowel		24x8.5	36 Pcs	8	Chipboard Screw		M3.5x12	32 Pcs
3	Ultra Shallow Cam		15x9.5	36 Pcs	9	Panel Screw (Black)		M3.5x12	20 Pcs
4	CSK Cap Wood Screw		M6x40	16 Pcs	10	Allen Key		M4	1 Pc
5	Wood Dowel		8x30	22 Pcs					

ASSEMBLY INSTRUCTIONS



Item No : W1596102397

Description : CHEST

Thank you for purchasing this quality product. Be sure to check all packing material carefully for small part that may have come loose inside the carton during shipment .

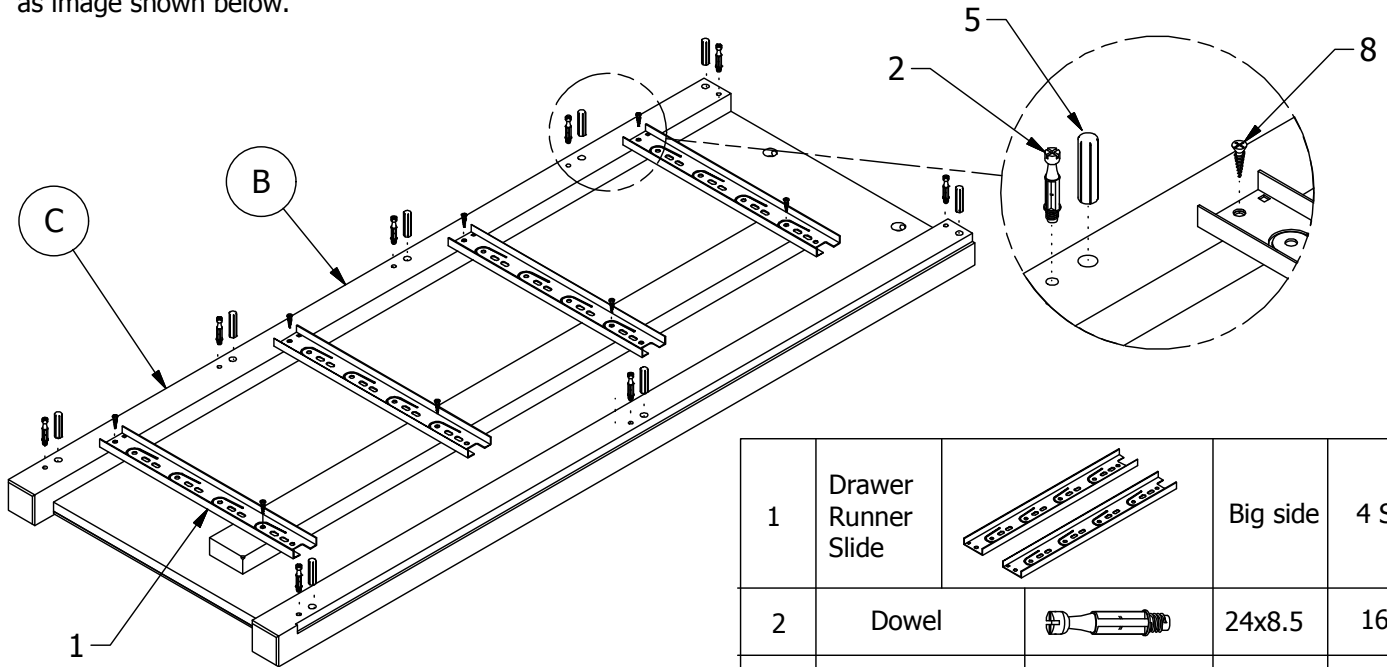
Step 1: Prepare the Cabinet Right Panel (B) & Cabinet Left Panel (C) then assemble the Drawer Runner Slide (1) on the pre-drilled holes with Chipboardboard Screw (8). Then insert the Dowel (2) & Wood Dowel (5) on each side of the cabinet as image shown below.

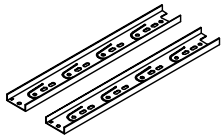

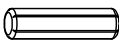
1	Drawer Runner Slide		Big side	4 Sets
2	Dowel		24x8.5	16 Pcs
8	Chipboard Screw		M3.5x12	16 Pcs
5	Wood Dowel		8x30	16 Pcs

Step 2: Attach the Front Structure Bone (N) & Back Structure Bone (O) with Ultra Shallow Cam (3) to the panel body to ready the cabinet structure as picture shown. ▽

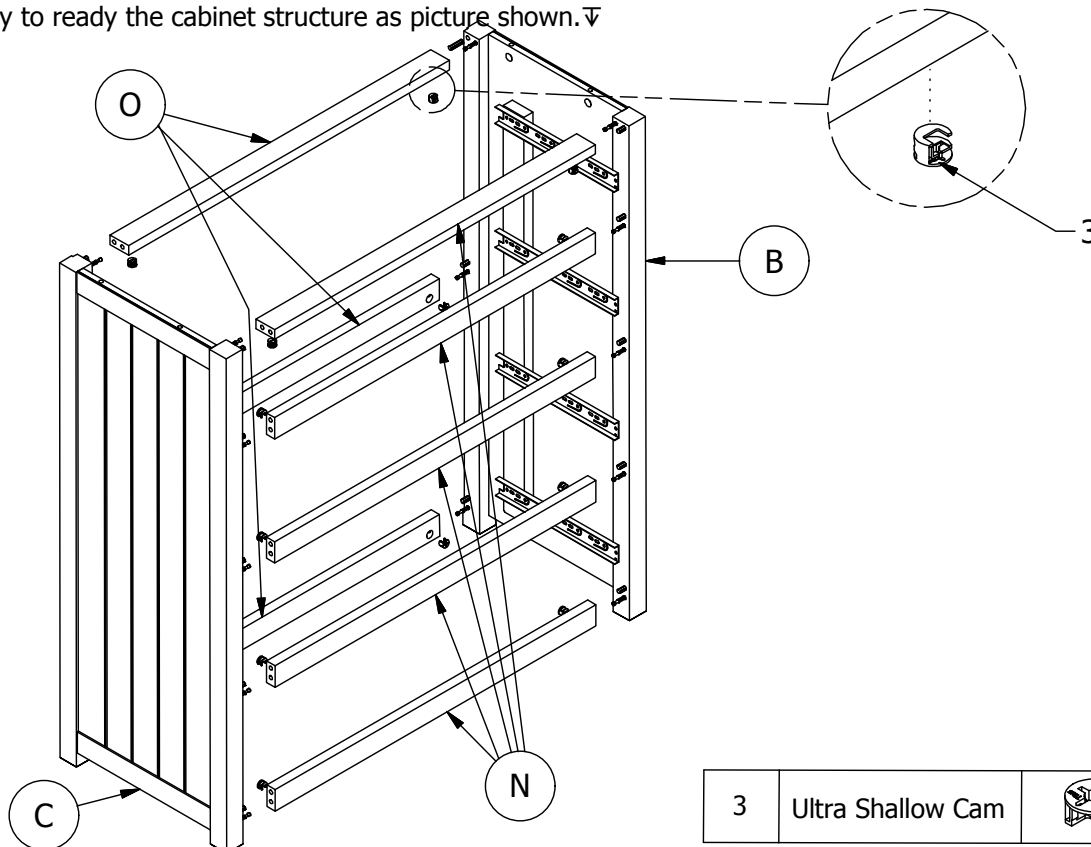

3	Ultra Shallow Cam		15x9.5	16 Pcs
---	-------------------	---	--------	--------

ASSEMBLY INSTRUCTIONS

Item No : W1596102397

Description : CHEST

Thank you for purchasing this quality product . Be sure to check all packing material carefully for small part that may have come loose inside the carton during shipment .

Step 3: Insert the Dowel (2) onto the pre-drilled holes on the bottom part of Table Top (A).

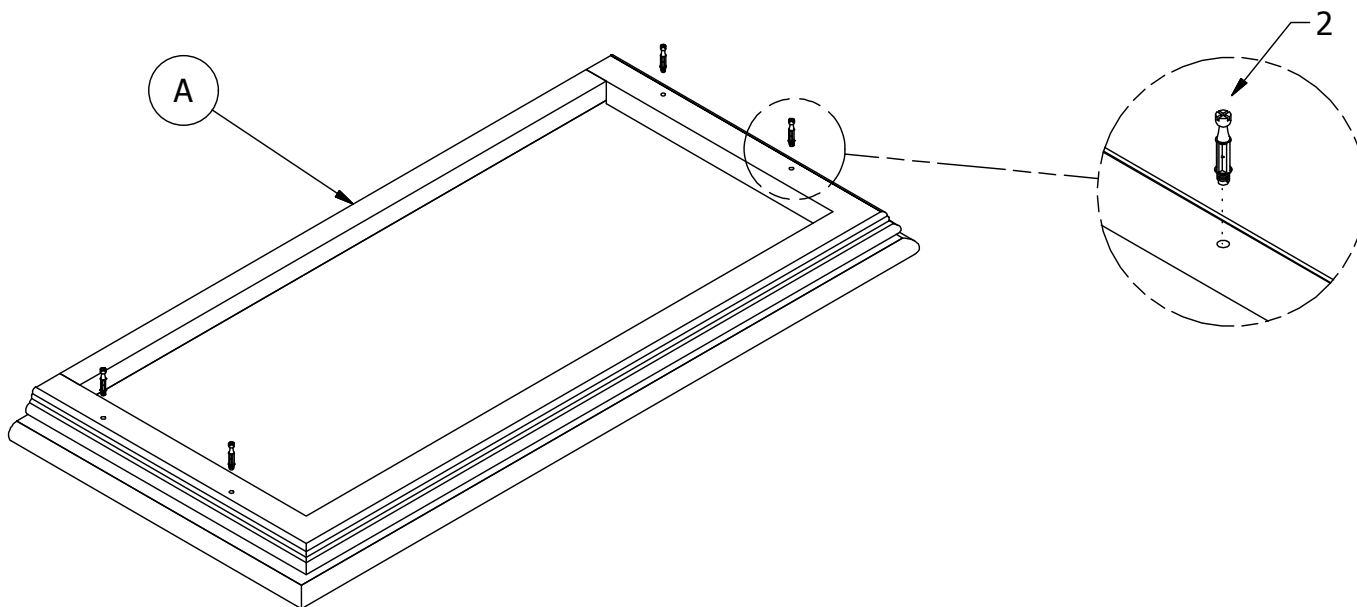

2	Dowel		24x8.5	4 Pcs
---	-------	---	--------	-------

Step 4: Ready the cabinet structure and flip the Table Top (A) to cover on top of the cabinet. Then tighten the attachment with Ultra Shallow Cam (3) with Dowel pre-installed in previous step 3. You would need to ready a screwdriver to perform this step.

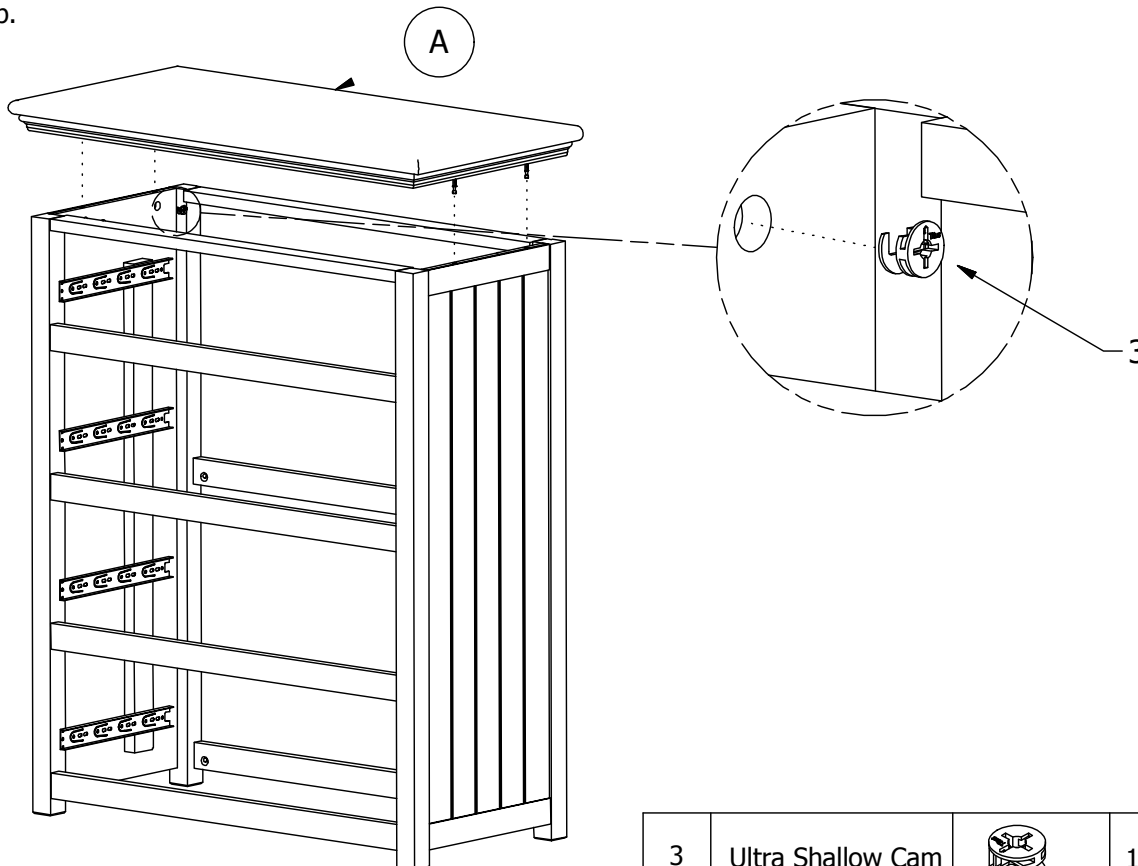

3	Ultra Shallow Cam		15x9.5	4 Pcs
---	-------------------	---	--------	-------

ASSEMBLY INSTRUCTIONS





Item No : W1596102397

Description : CHEST

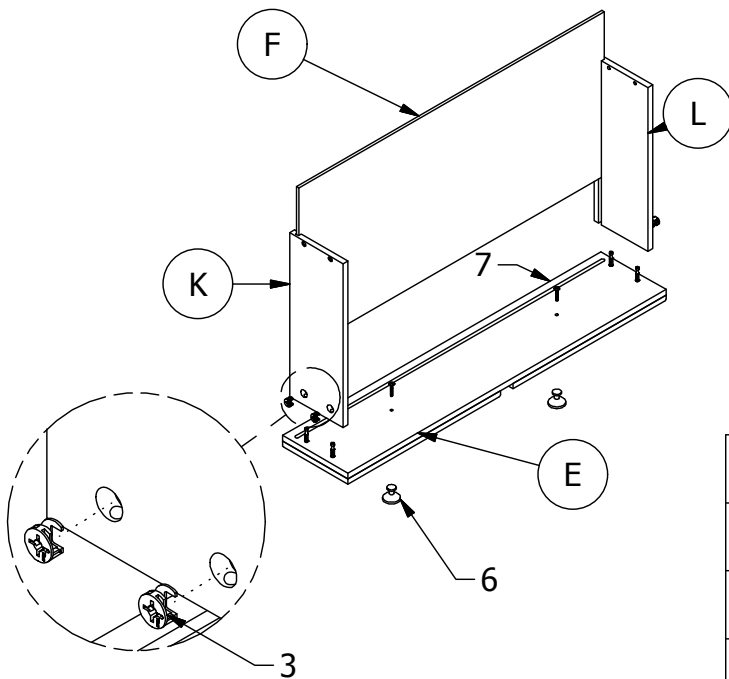
Thank you for purchasing this quality product . Be sure to check all packing material carefully for small part that may have come loose inside the carton during shipment .



Step 5: Lay the Drawer Front Panel (E) on even-layered flat surface, put in the Dowel (2) on each side and take the Top Drawer L/R Panel (K & L) attach into the Pre-drilled holes of the Front Panel (E), tighten the part with Ultra Shallow Cam (3). Next, slide in the Drawer Bottom Board (F) finish up with screwing the Handle (6) with using Handle Screw (7).

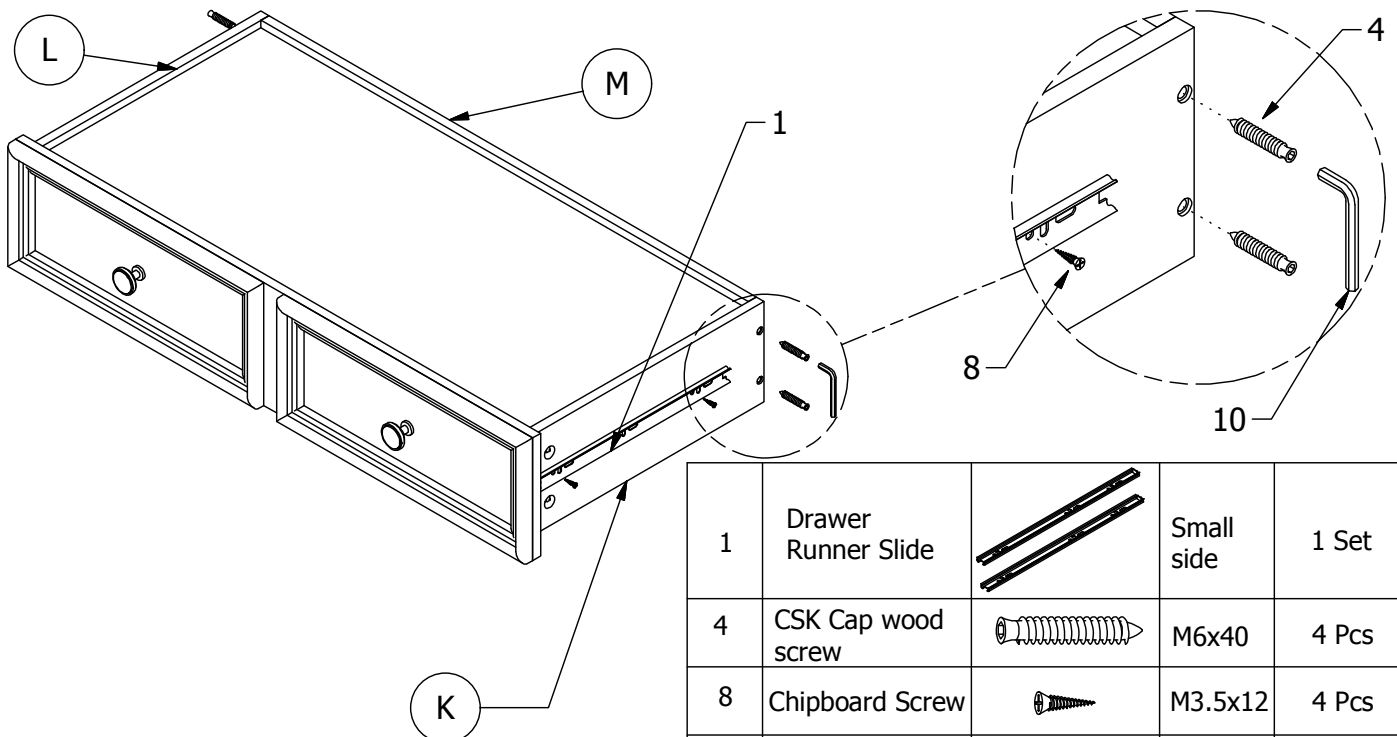

2	Dowel		24x8.5	4 Pcs
3	Ultra Shallow Cam		15x9.5	4 Pcs
6	Handle		15x9.5	2 Pcs
7	Handle Screw		M4x22	2 Pcs

Step 6: Setting up the Drawer with its Top Drawer Back Panel (M) with CSK Cap Wood Screw (4) with the help of Allen Key (10). Assemble the Drawer Runner Slide (1) to the Drawer Panel (K & L) by using Chipboard Screw (8).

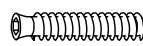

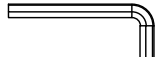
1	Drawer Runner Slide		Small side	1 Set
4	CSK Cap wood screw		M6x40	4 Pcs
8	Chipboard Screw		M3.5x12	4 Pcs
10	Allen Key		M4	1 Pc

ASSEMBLY INSTRUCTIONS

Item No : W1596102397





Description : CHEST

Thank you for purchasing this quality product . Be sure to check all packing material carefully for small part that may have come loose inside the carton during shipment .

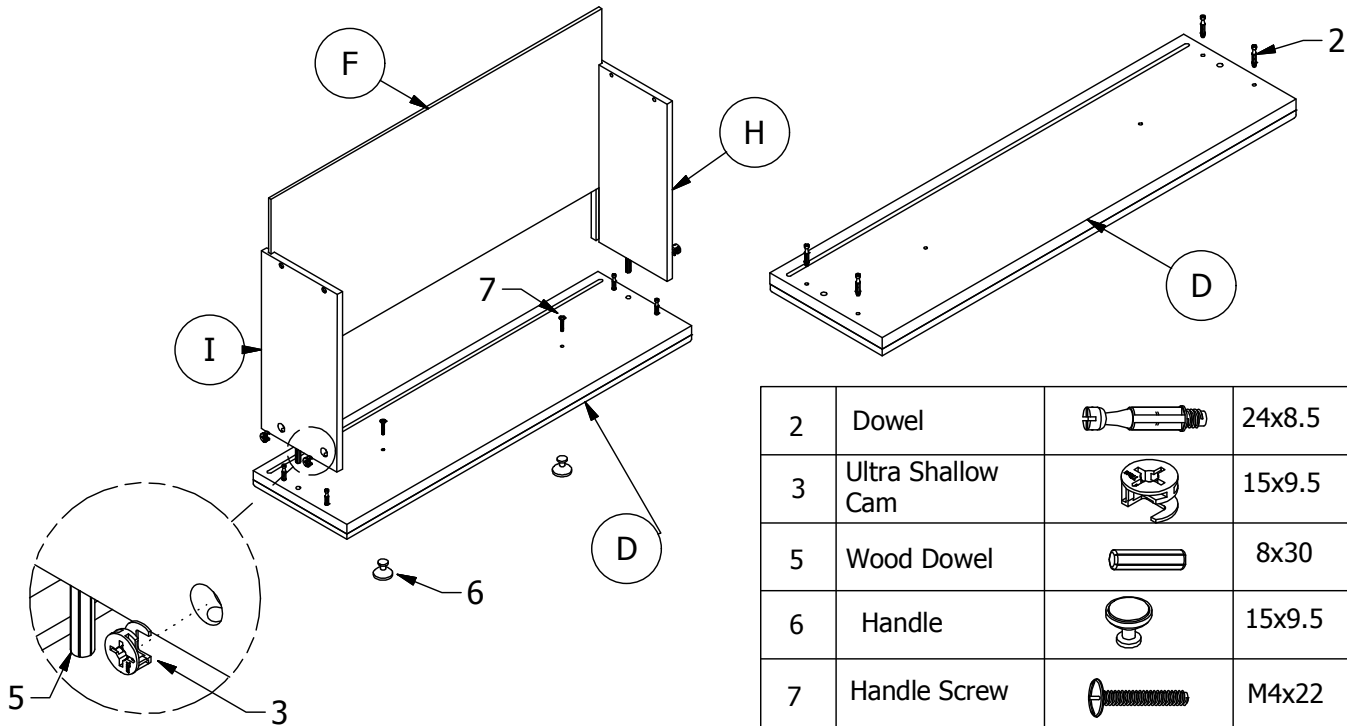
Important: Wood Dowel (5) ONLY to be inserted on pre-drilled holes of Drawer Right Panel (H) & Drawer Left Panel (I)





Step 7: Lay the Drawer Front Panel (D) on even-layered flat surface, put in the Dowel (2) on each side and take the Drawer Panel (H & I) attach into the Pre-drilled holes of the Front Panel, tighten the part with Ultra Shallow Cam (3). Next, slide in the Drawer Bottom Board (F) finish up with screwing the Handle (6) with using Handle Screw (7).

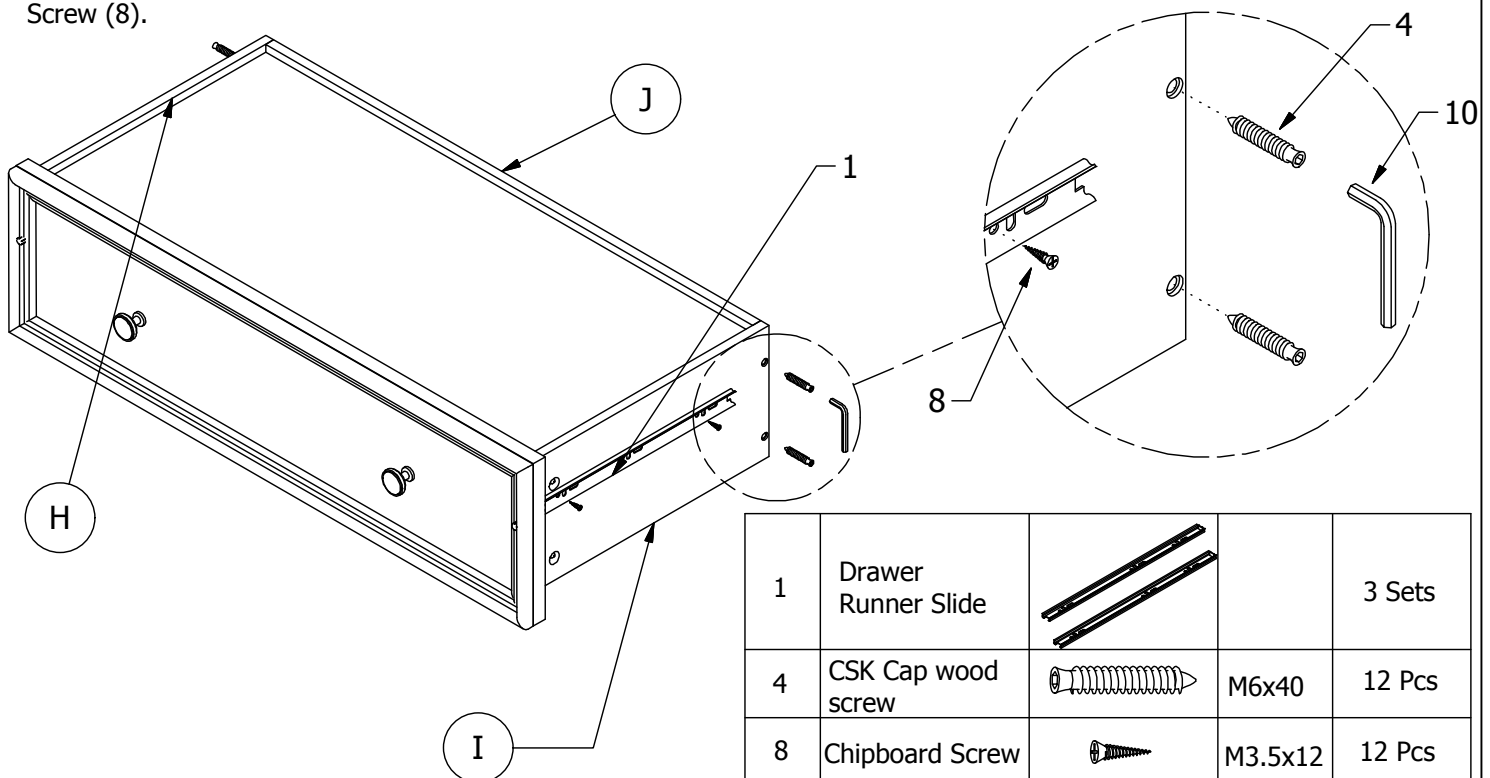

2	Dowel		24x8.5	12 Pcs
3	Ultra Shallow Cam		15x9.5	12 Pcs
5	Wood Dowel		8x30	6 Pcs
6	Handle		15x9.5	6 Pcs
7	Handle Screw		M4x22	6 Pcs

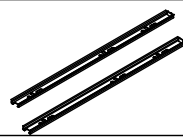
Step 8: Setting up the Drawer with its Drawer Back Panel (J) with CSK Cap Screw (4) with the help of Allen Key (10). Assemble the Drawer Runner Slide (1) to the Drawer Panel (H & I) by using Chipboard Screw (8).



1	Drawer Runner Slide			3 Sets
4	CSK Cap wood screw		M6x40	12 Pcs
8	Chipboard Screw		M3.5x12	12 Pcs
10	Allen Key		M4	1 Pc

ASSEMBLY INSTRUCTIONS

Item No : W1596102397

Description : CHEST

Thank you for purchasing this quality product . Be sure to check all packing material carefully for small part that may have come loose inside the carton during shipment .

Step 9: Cover up the back of cabinet with Cabinet Back Panel (G) by using Panel Screw (Black) (9).

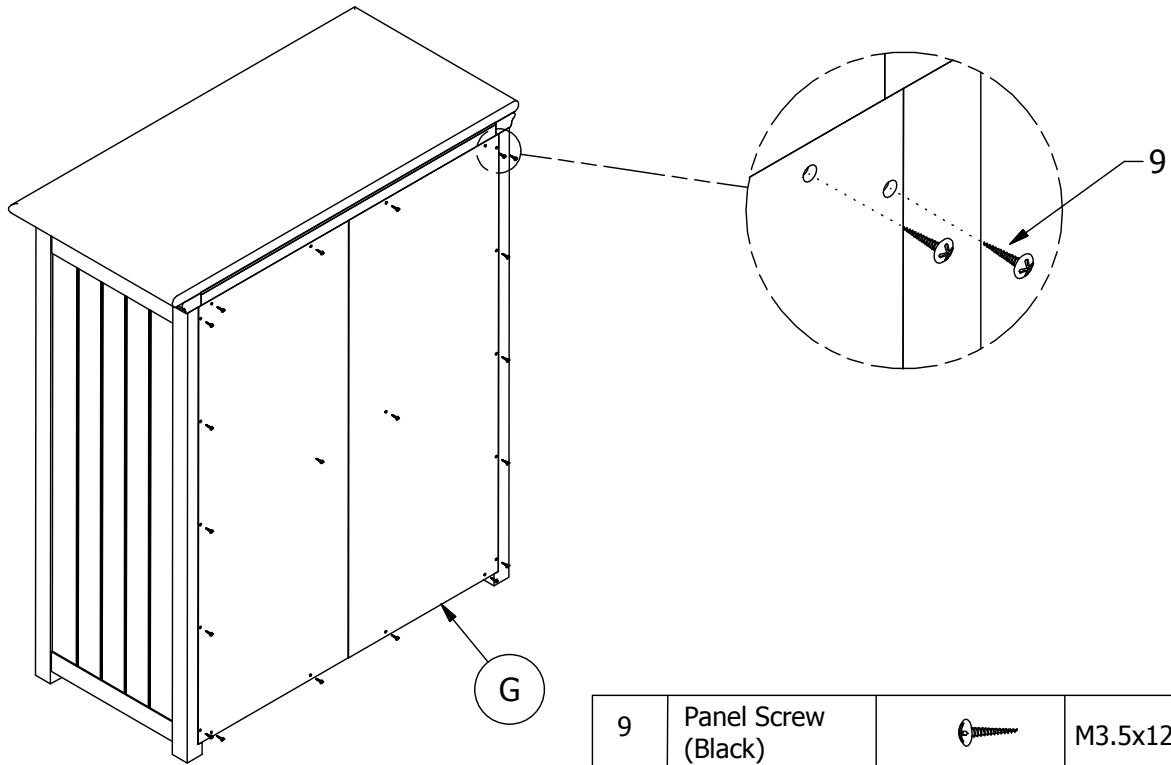

9	Panel Screw (Black)		M3.5x12	20 Pcs
---	------------------------	---	---------	--------

Finally, glide in the drawers and make sure the slide glide in smoothly into the track, not sitting on top of the runner track.

