

ASSEMBLY INSTRUCTIONS

Item No : W1596102395

Description : KING BED

Thank you for purchasing this quality product. Be sure to check all packing material carefully for small part that may have come loose inside the carton during shipment.

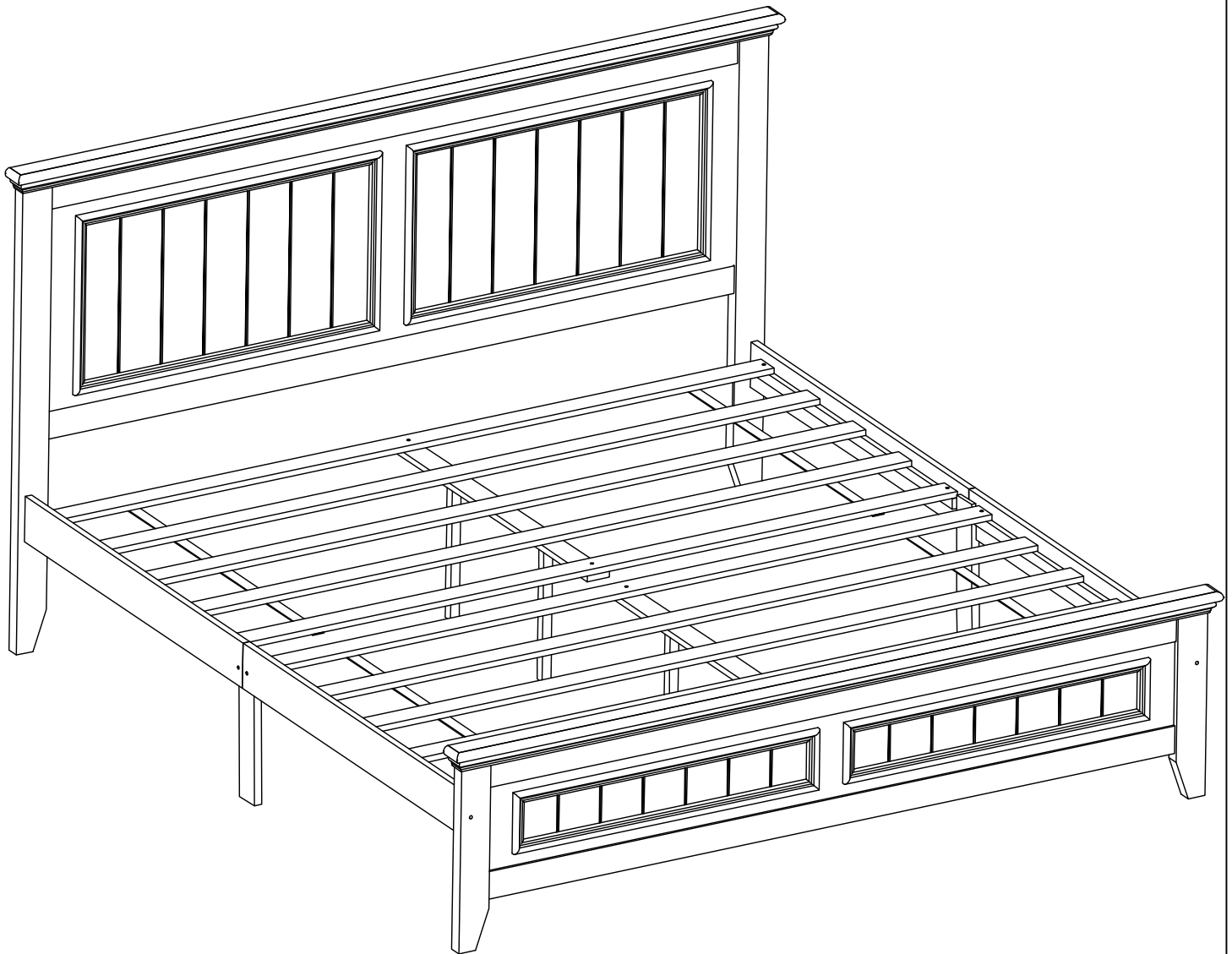

W1596102375

ASSEMBLY INSTRUCTIONS

Item No : W1596102395

Description : KING BED

Thank you for purchasing this quality product. Be sure to check all packing material carefully for small part that may have come loose inside the carton during shipment.

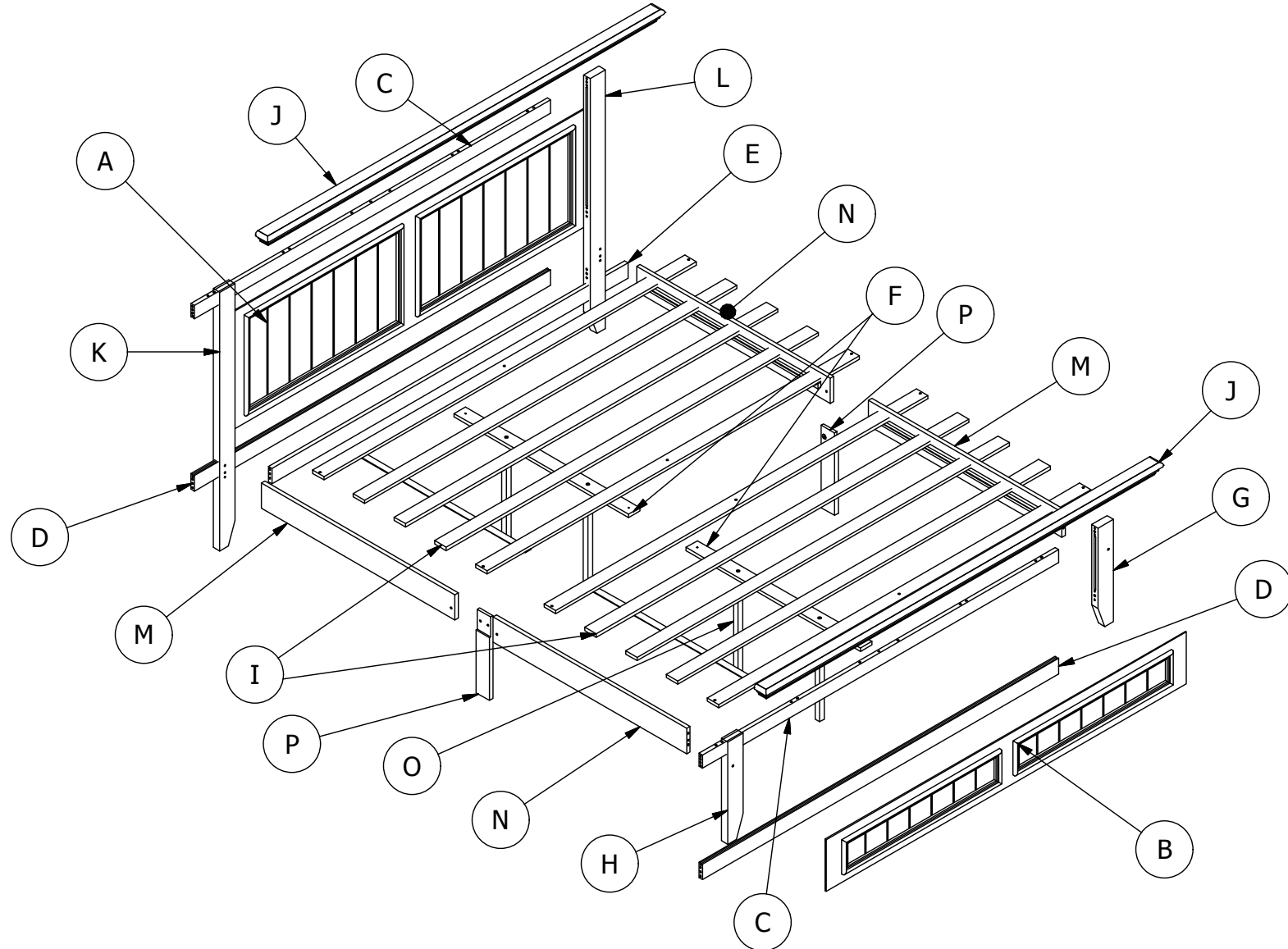









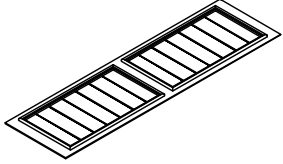
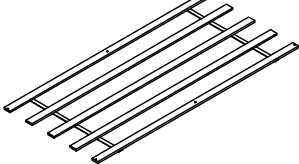
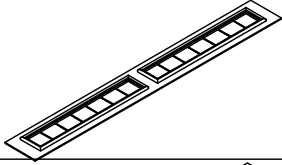
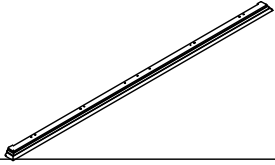
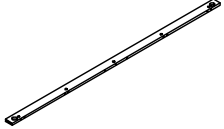
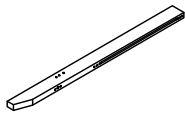
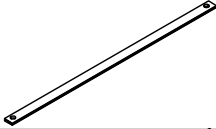
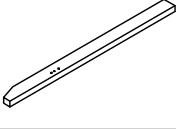
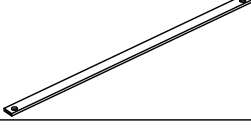
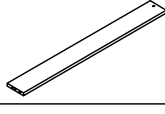
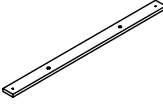
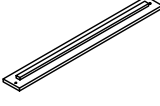

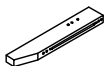





ASSEMBLY INSTRUCTIONS

Item No : W1596102395

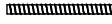
Description : KING BED

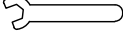
Thank you for purchasing this quality product. Be sure to check all packing material carefully for small part that may have come loose inside the carton during shipment.

PART LIST:				PART LIST:			
No.	Description	Sketch	Quantity	No.	Description	Sketch	Quantity
A	Headboard		1 Pc	I	Slat Base		2 Sets
B	Footboard		1 Pc	J	Headboard & Footboard Top Cap		2 Pcs
C	Headboard & Footboard Horizontal Bone (Panel)		2 Pcs	K	Headboard Bedpost -L		1 Pc
D	Headboard & Footboard-Bottom Horizontal Bone (Panel)		2 Pcs	L	Headboard Bedpost -R		1 Pc
E	Headboard Horizontal Bedpost Bone		1 Pc	M	Side Rails		2 Pcs
F	Center Rail Support		2 Pcs	N	Side Rails		2 Pcs
G	Footboard Bedpost -R		1 Pc	O	Center Rail Support Legs		4 Pcs
H	Footboard Bedpost -L		1 Pc	P	Side Rail Support Legs		2 Pcs

HARDWARE LIST:					HARDWARE LIST:				
No.	Description	Sketch	Size	Quantity	No.	Description	Sketch	Size	Quantity
1	JCBC		M6x70	4 Pcs	8	JCBC-W		M7x40	4 Pcs
2	JRN Nut		M6 10x13	4 Pcs	9	Wood Dowel		M8x40	40 Pcs
3	JCBC		M6x30	4 Pcs	10	Chipboard Screw		M4x30	12 Pcs
4	Allen Key		M4	1 Pc	11	Full Thread M6x70			10 Pcs
5	Ultra Shallow Cam		24x8.5	10 Pcs	12	Spanner			1 Pc
6	Dowel		15x9.5	8 Pcs	13	Hex Nut M6			10 Pcs
7	Wood Block			10 Pcs	14	Spring Washer			10 Pcs

ASSEMBLY INSTRUCTIONS

Item No : W1596102395

Description : KING BED

Thank you for purchasing this quality product. Be sure to check all packing material carefully for small part that may have come loose inside the carton during shipment.



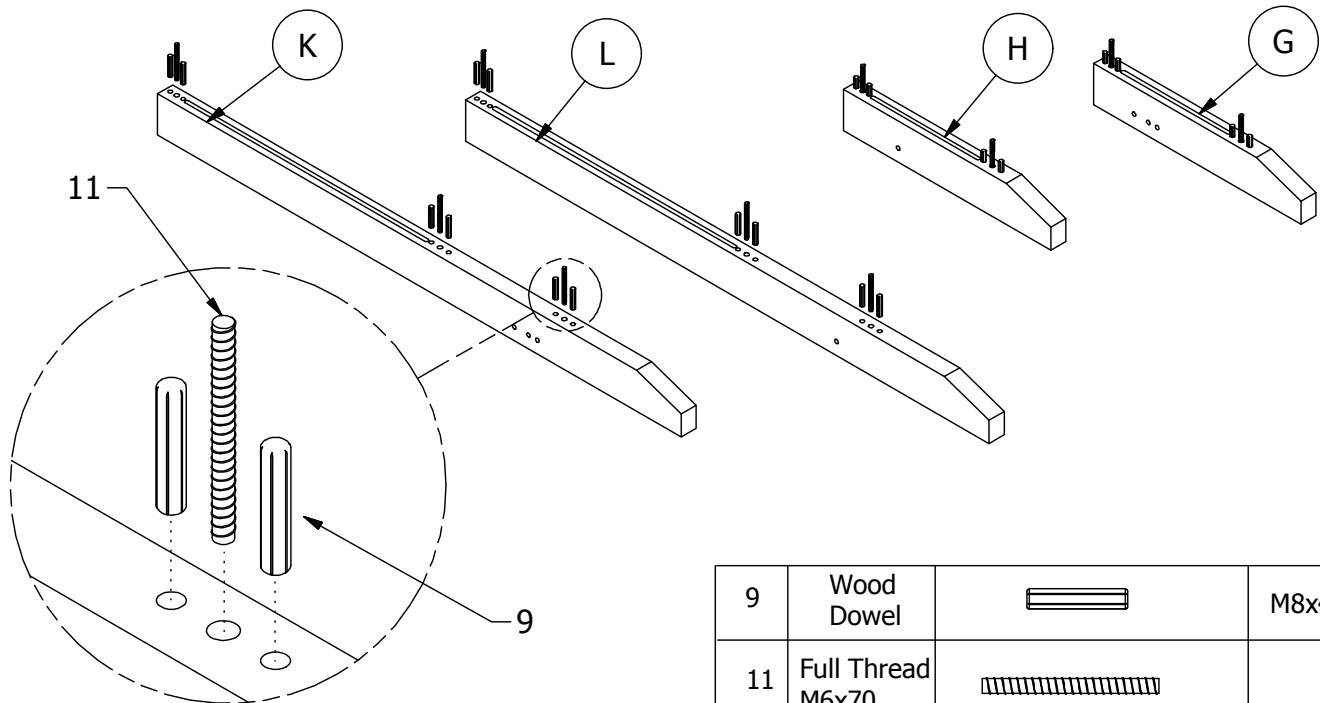

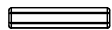
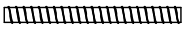
Step 1: Insert the Wood Dowel (9) & Full Thread M6x70 (11) to all the Bedpost (K, L, H, G) pre-drilled holes by hand.

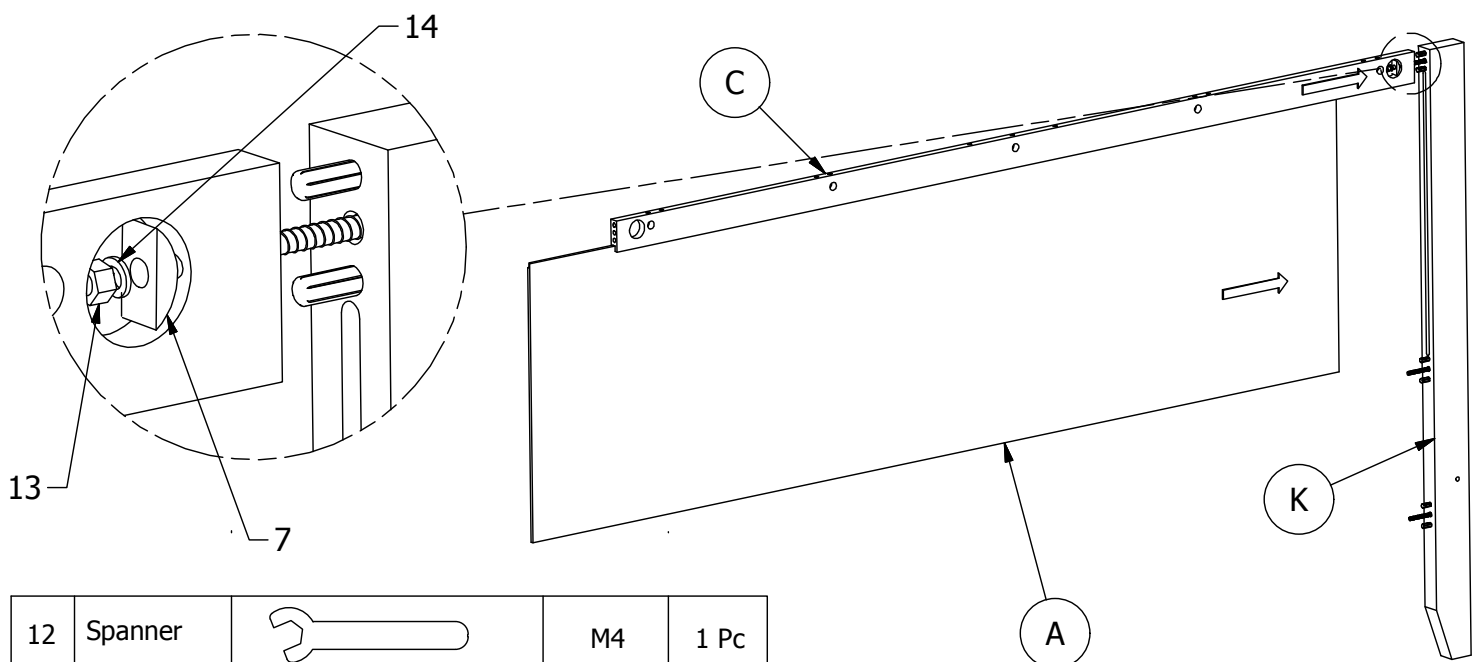

9	Wood Dowel		M8x40	20 Pcs
11	Full Thread M6x70			10 Pcs

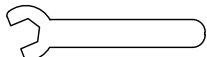
Step 2: Slide in the Headboard Panel (A) into the ditch groove of the Headboard Horizontal Bone (C). Bring the part to attach to the Headboard Bedpost-L (K). Next insert the Wood Block (7) into the hole & push in tightly, tighten the connection with inserting Spring Washer (14) follow with Hex Nut M6 (13), you may use the Spanner (12) provided.



12	Spanner		M4	1 Pc
7	Wood Block			1 Pc
13	Hex Nut M6			1 Pc
14	Spring Washer			1 Pc

ASSEMBLY INSTRUCTIONS





Item No : W1596102395

Description : KING BED

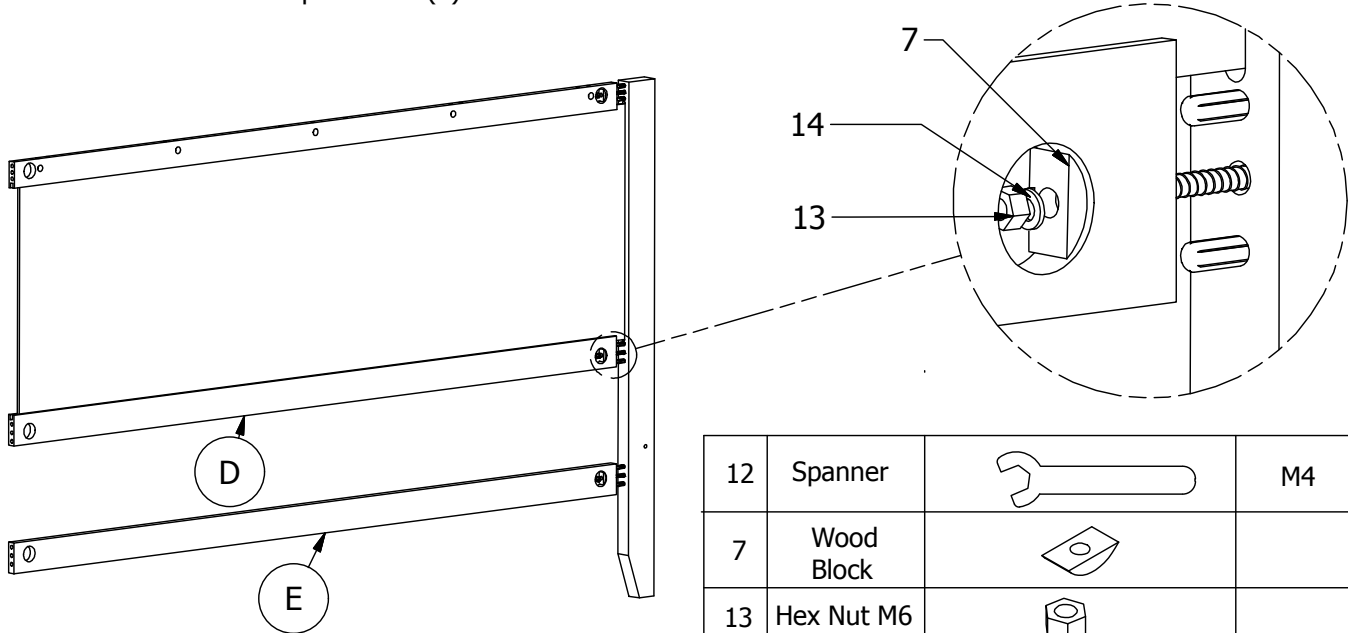
Thank you for purchasing this quality product. Be sure to check all packing material carefully for small part that may have come loose inside the carton during shipment.

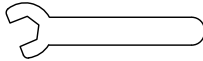



Step 3: Slide in the Headboard-Bottom Horizontal Bone (Panel) (D) and push in to the Bedpost, repeat the Step 3 by inserting the Wood Block (7), Spring Washer (14) & Hex Nut M6 (13) by using Spanner (12). Next push in the Headboard Horizontal Bedpost Bone (E).

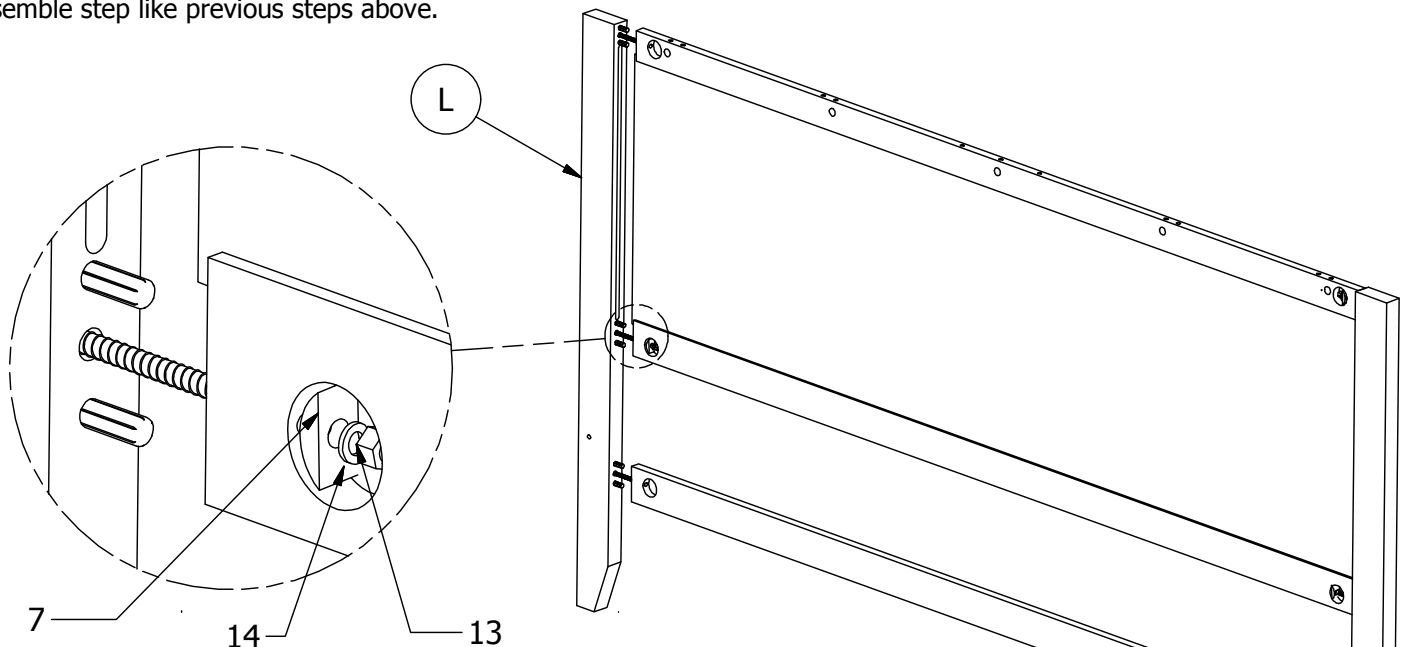

12	Spanner		M4	1 Pc
7	Wood Block			2 Pcs
13	Hex Nut M6			2 Pcs
14	Spring Washer			2 Pcs

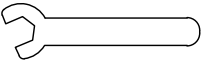
Step 4: One side of Headboard Bedpost with Headboard Panel is ready.... attach it with Headboard Bedpost-R (L). Repeat the assemble step like previous steps above.



12	Spanner		M4	1 Pc
7	Wood Block			3 Pcs
13	Hex Nut M6			3 Pcs
14	Spring Washer			3 Pcs

ASSEMBLY INSTRUCTIONS



Item No : W1596102395

Description : KING BED

Thank you for purchasing this quality product. Be sure to check all packing material carefully for small part that may have come loose inside the carton during shipment.

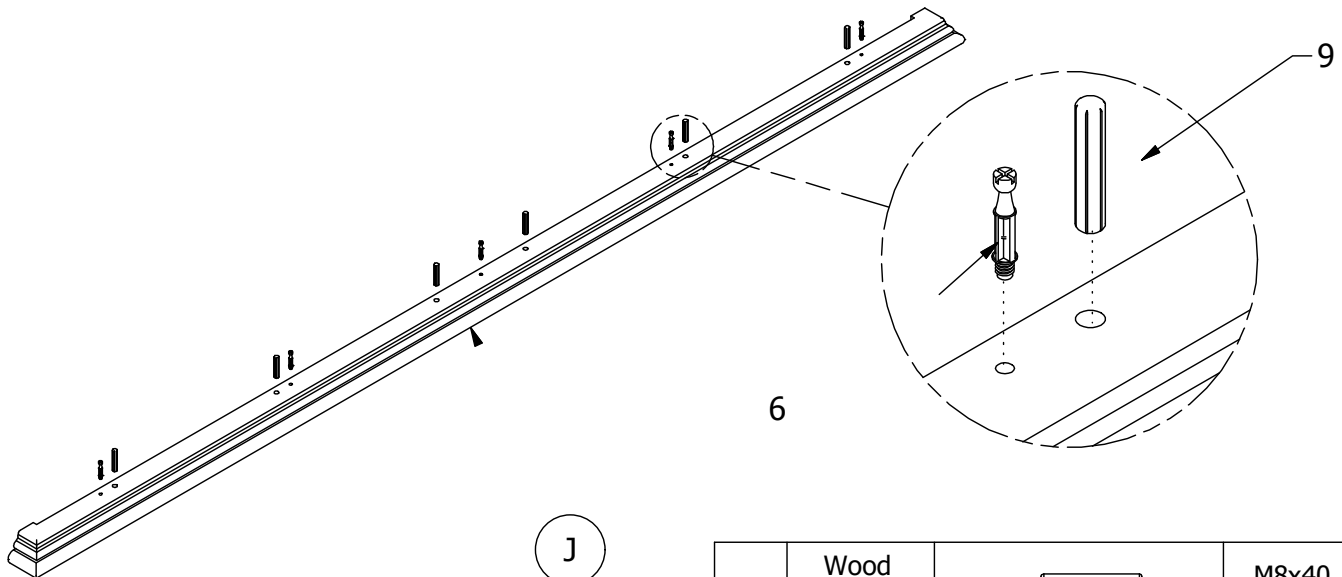
Step 5: Insert the Wood Dowel (9) & Dowel (6) on the pre-drilled holes (at bottom) of the Headboard Top Cap (J).

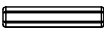

9	Wood Dowel		M8x40	4 Pcs
6	Dowel		24x8.5	4 Pcs

Step 6: Push-attach the Headboard Top Cap (J) into the headboard panel part assembled earlier. Then tighten the connection with Ultra Shallow Cam (5), you will need to prepare a screwdriver.

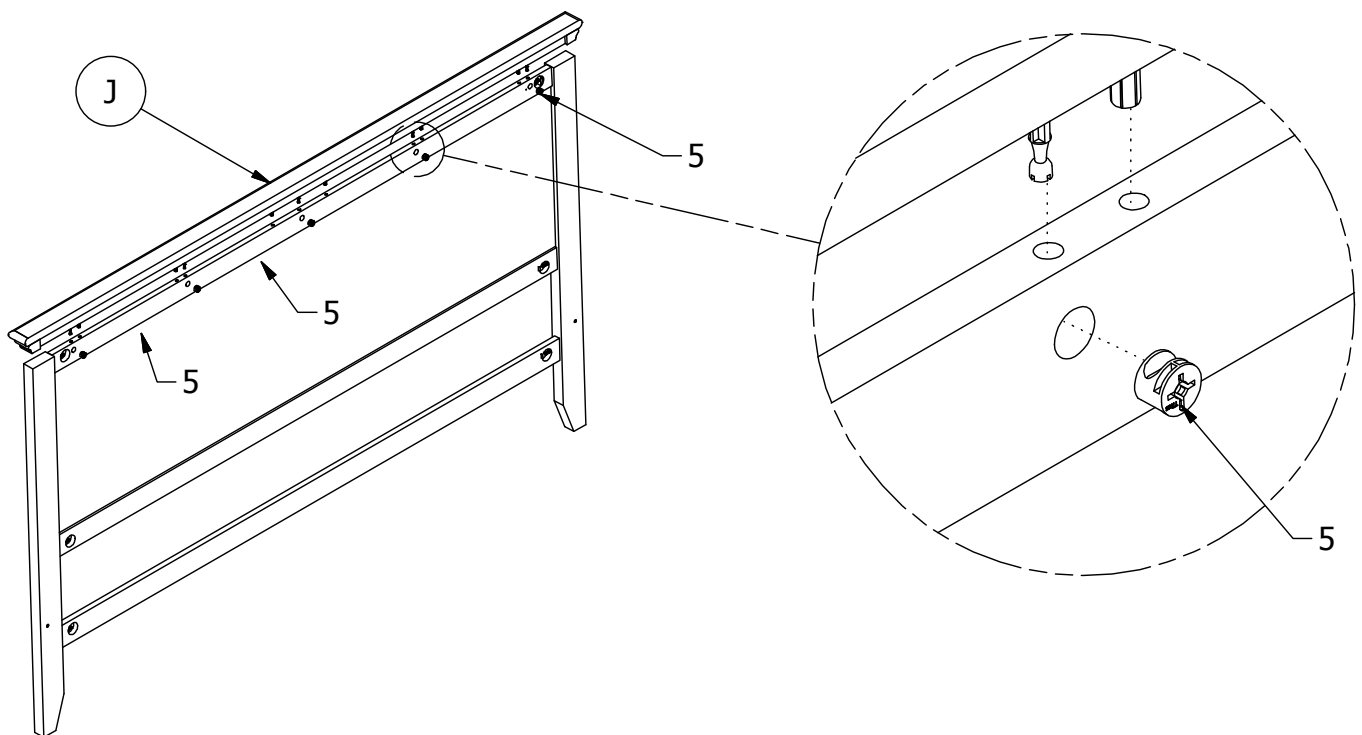

5	Ultra Shallow Cam		15x9.5	4 Pcs
---	-------------------	---	--------	-------

ASSEMBLY INSTRUCTIONS

Item No : W1596102395





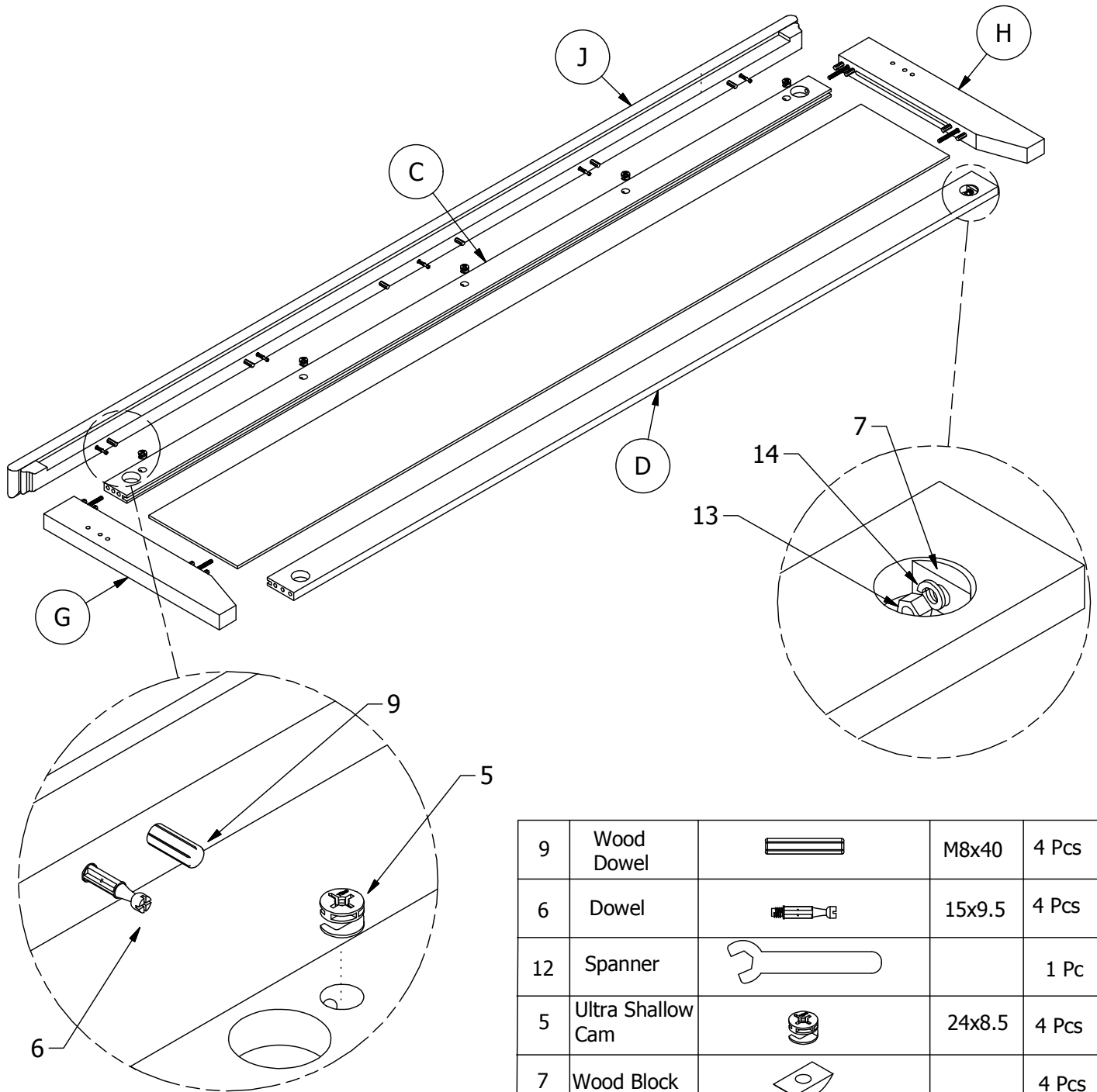

Description : KING BED

Thank you for purchasing this quality product. Be sure to check all packing material carefully for small part that may have come loose inside the carton during shipment.

Step 7: Footboard assembling repeat as like Headboard steps. Follow the sequence from Step 3 to Step 6.

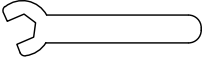
*** Part E is ignored, not exist.



9	Wood Dowel		M8x40	4 Pcs
6	Dowel		15x9.5	4 Pcs
12	Spanner			1 Pc
5	Ultra Shallow Cam		24x8.5	4 Pcs
7	Wood Block			4 Pcs
13	Hex Nut M6			4 Pcs
14	Spring Washer			4 Pcs

ASSEMBLY INSTRUCTIONS



Item No : W1596102395

Description : KING BED

Thank you for purchasing this quality product. Be sure to check all packing material carefully for small part that may have come loose inside the carton during shipment.

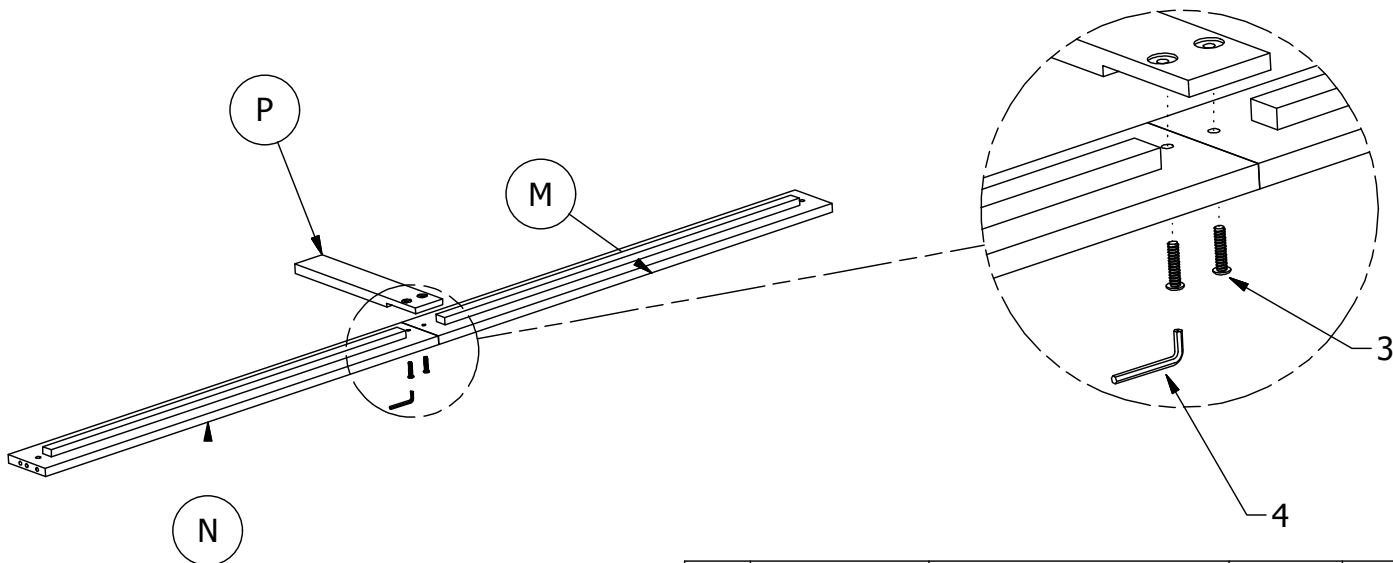

Step 3: Lay the side Rail (M & N) parallel, put in the Wood Dowel (4) into pre-drilled holes, align the Support Side Rail (H) on the center of the gap and screw to the 2 rails with using Chipboard Screw (3).

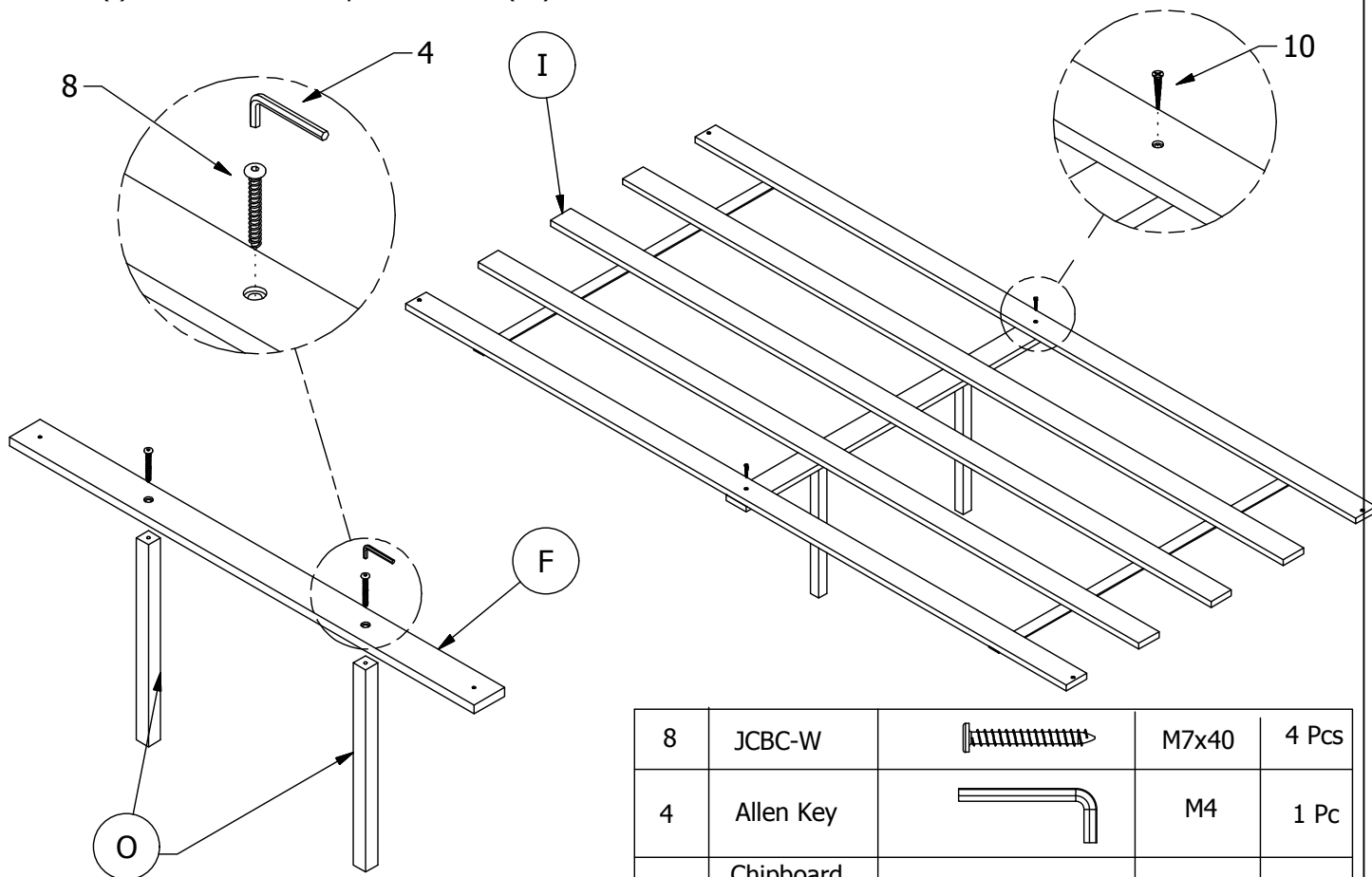

4	Allen Key		M4	1 Pc
3	JCBC		M6X30	4 Pcs

Step 4: Take the Slat Support Leg (O) to attach with Center Rail (F) by screwing with JCBC-W (8) using Allen Key (4). Next lay the Slat Base (I) and screw with Chipboard Screw (10).

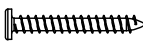

8	JCBC-W		M7x40	4 Pcs
4	Allen Key		M4	1 Pc
10	Chipboard Screw		M4x30	4 Pcs

ASSEMBLY INSTRUCTIONS





Item No : W1596102395

Description : KING BED

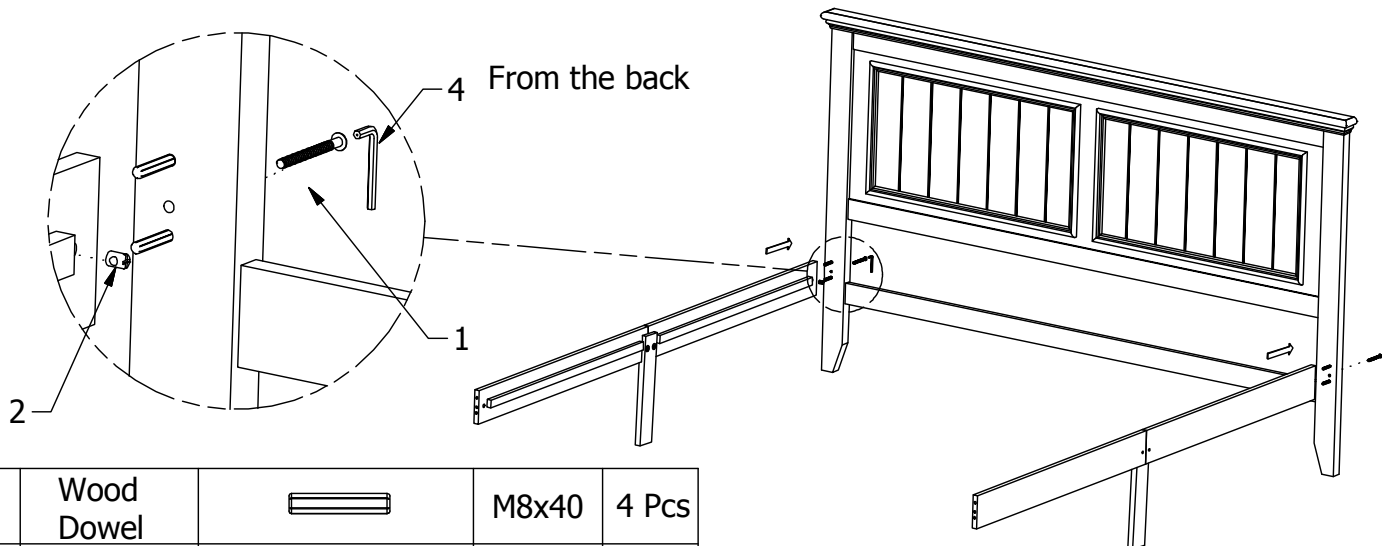
Thank you for purchasing this quality product. Be sure to check all packing material carefully for small part that may have come loose inside the carton during shipment.

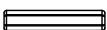

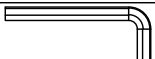
Step 8: Insert Wood Dowel (9) into bedpost's pre-drilled holes. Take Side Rail (M & N) to push-insert to pre-attach Wood Dowel on the Headboard Bedpost. Then put in the JRN Nut (2) to the pre-drilled holes of side rails and insert JCBC (1) from the back of posters, tighten- screw from the back by using Allen Key (4).

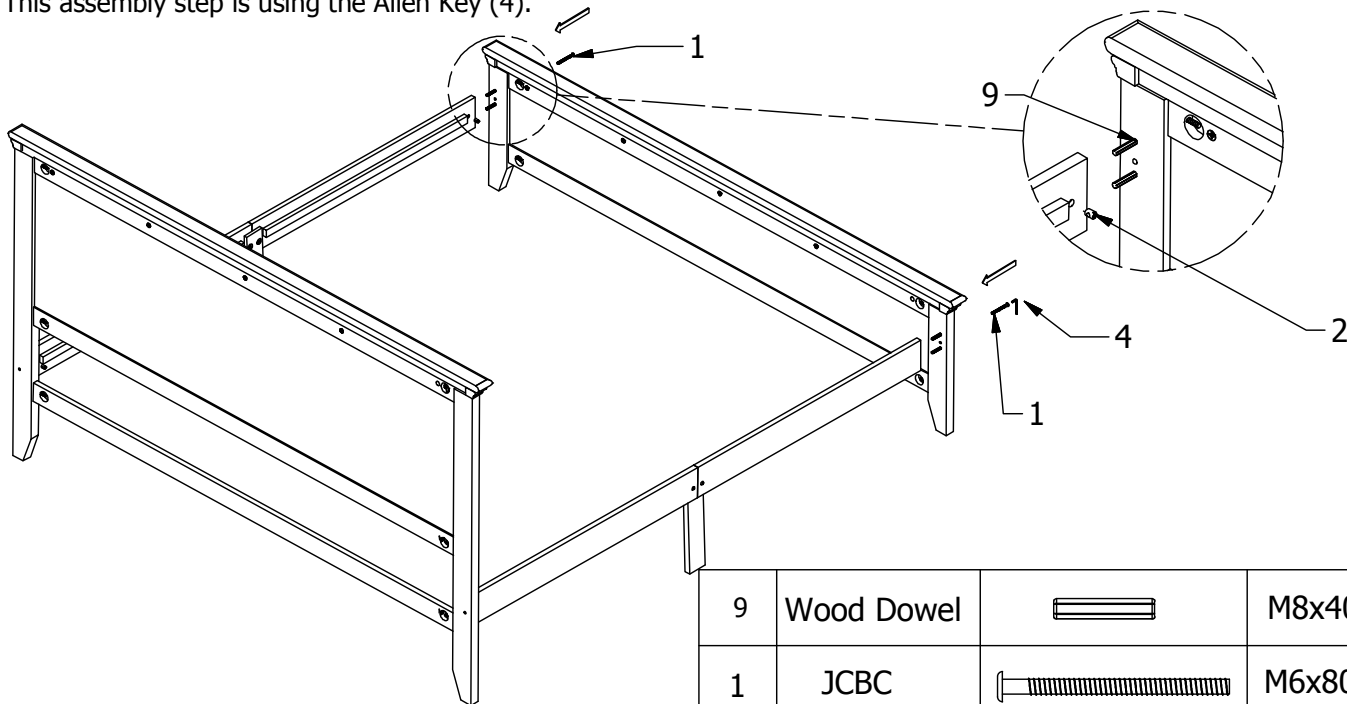

9	Wood Dowel		M8x40	4 Pcs
1	JCBC		M6x80	2 Pcs
4	Allen Key		M4	1 Pc
2	JRN Nut		M6 10x13	2 Pcs

Step 5: Pre-insert Wood Dowel (9) on the Footboard Posters (G / H). Take Side Rail (M & N) to push in to the wood dowel. Then put in the JRN Nut (2) on the pre-drilled hole and use JCBC (1) to tighten- screw from the front of footboard posters. This assembly step is using the Allen Key (4).

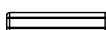
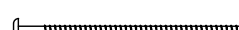
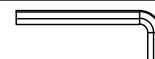

9	Wood Dowel		M8x40	4 Pcs
1	JCBC		M6x80	2 Pcs
4	Allen Key		M4	1 Pc
2	JRN Nut		M6 10x13	2 Pcs

ASSEMBLY INSTRUCTIONS

Item No : W1596102395

Description : KING BED

Thank you for purchasing this quality product. Be sure to check all packing material carefully for small part that may have come loose inside the carton during shipment.

Finally neatly lay the Slat Base (J) on the Side Rails (M & N) which already assembled, and tighten them with using Chipboard Screw (10).

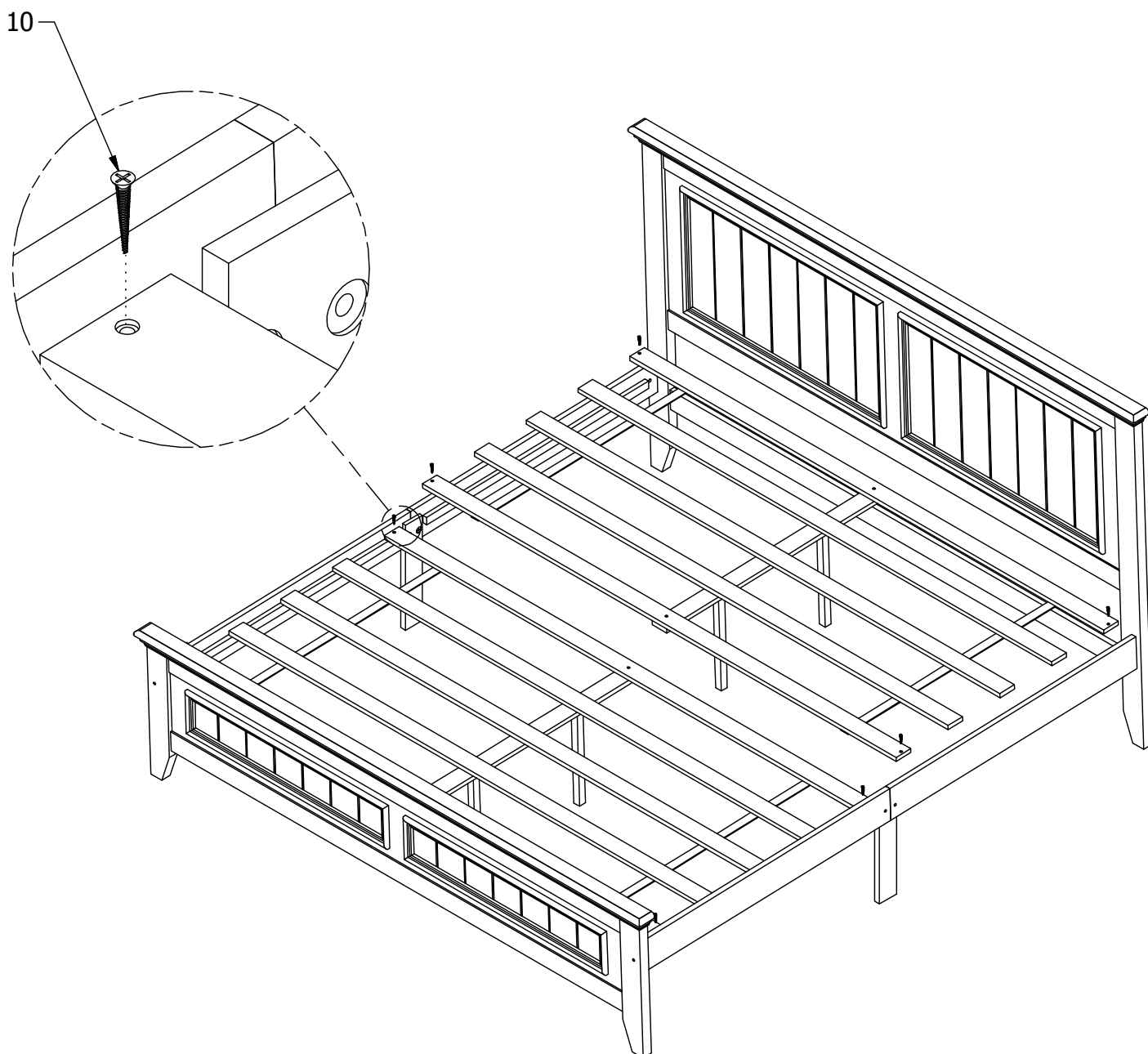

10	Chipboard Screw		M4x30	8Pcs
----	--------------------	---	-------	------