

ASSEMBLY INSTRUCTIONS

Item No : W1596102258

Description : CHEST

Thank you for purchasing this quality product. Be sure to check all packing material carefully for small part that may have come loose inside the carton during shipment.

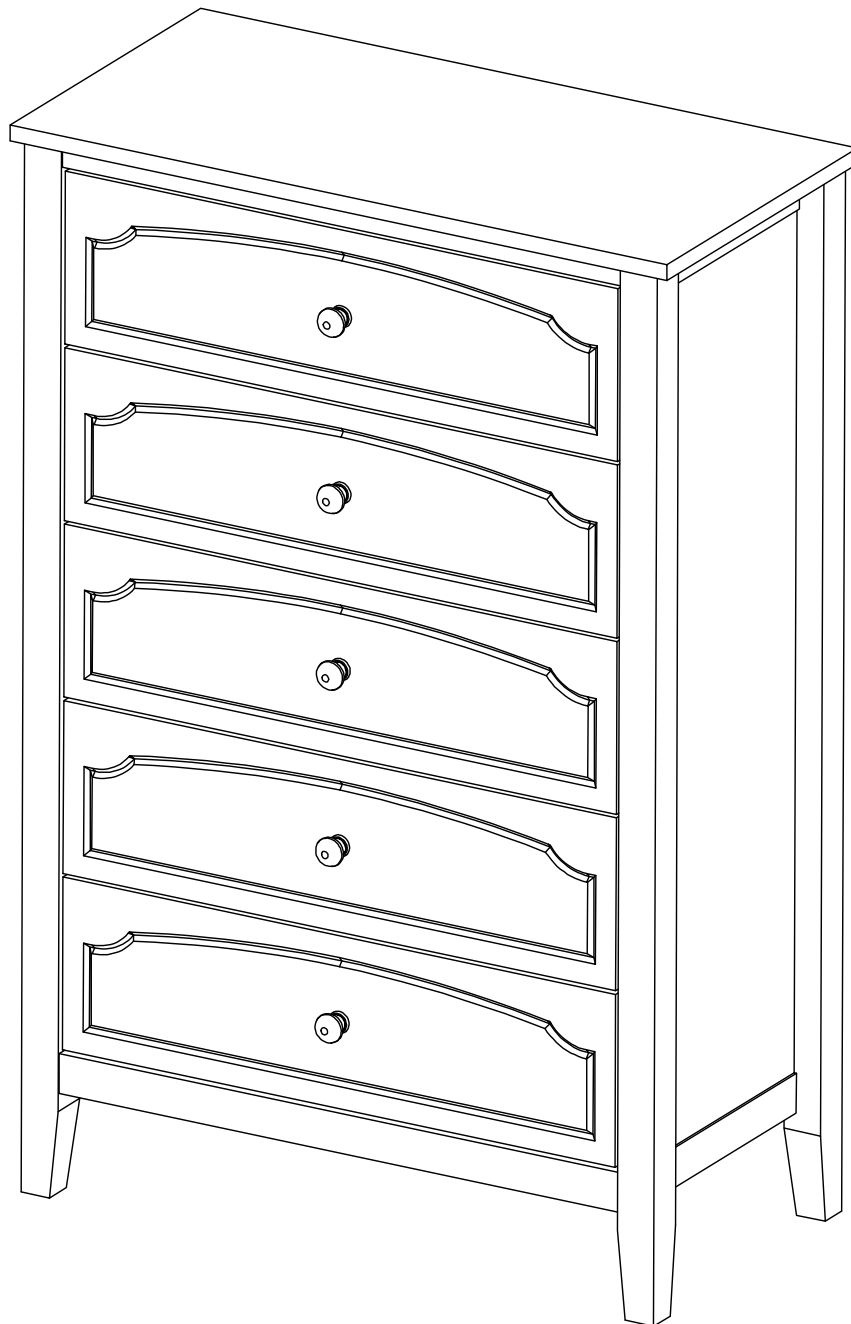

W1596102258

ASSEMBLY INSTRUCTIONS

Item No : W1596102258

Description : CHEST

Thank you for purchasing this quality product. Be sure to check all packing material carefully for small part that may have come loose inside the carton during shipment .

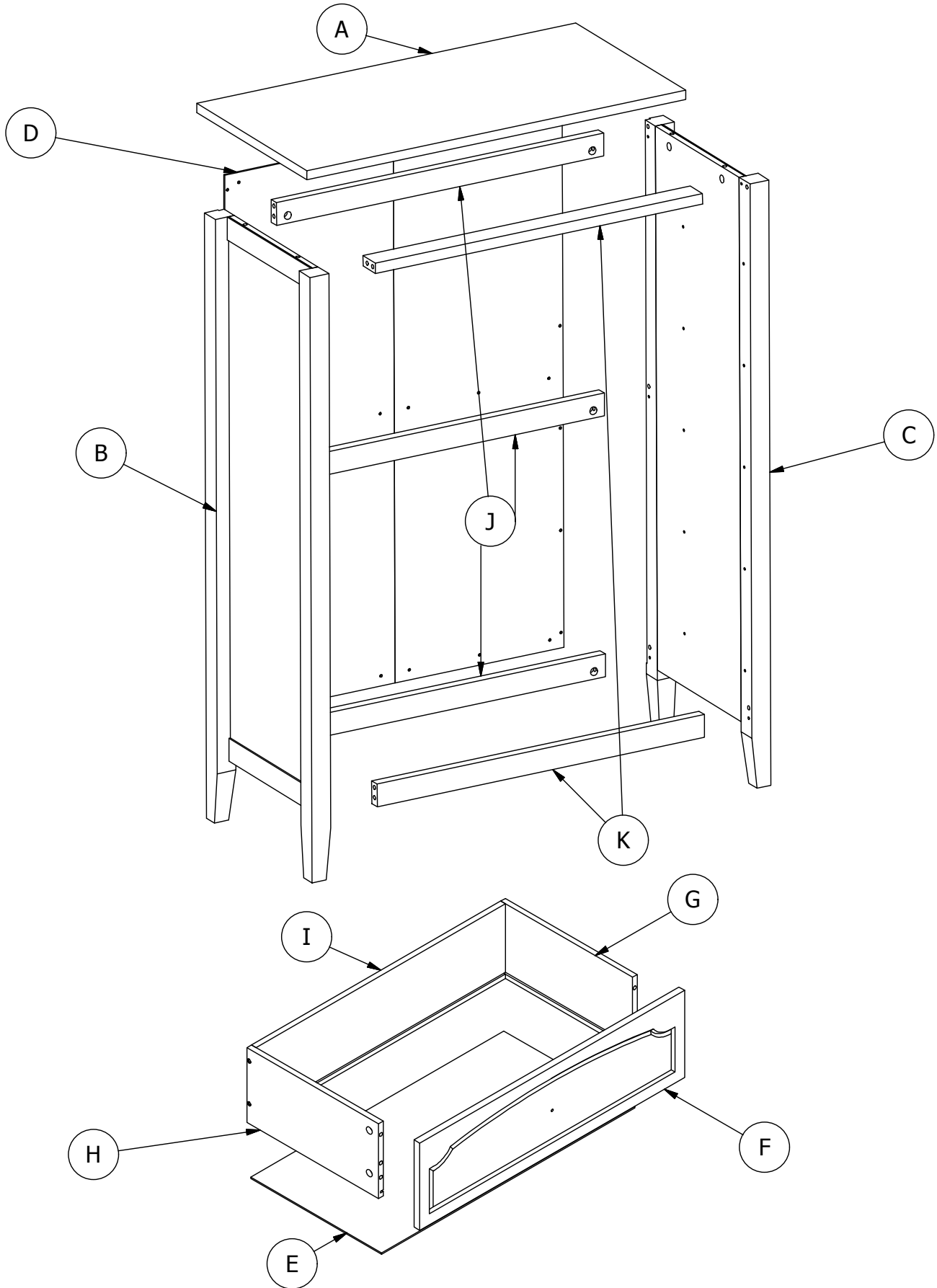

ASSEMBLY INSTRUCTIONS

Item No : W1596102258







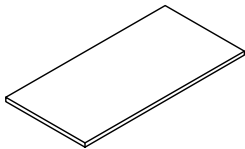
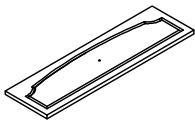
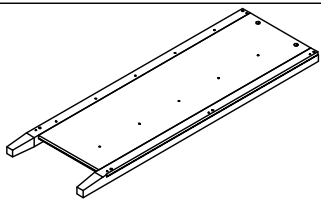
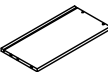
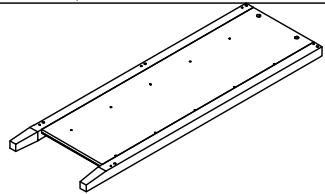
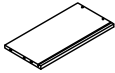
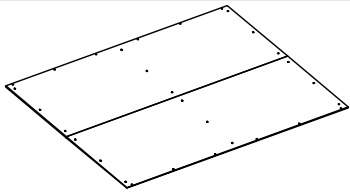
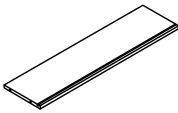
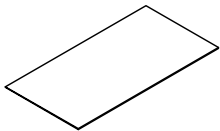
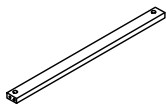
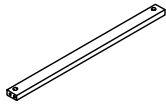

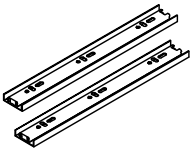

Description : CHEST

Thank you for purchasing this quality product . Be sure to check all packing material carefully for small part that may have come loose inside the carton during shipment .

PART LIST:

No.	Description	Sketch	Quantity	No.	Description	Sketch	Quantity
A	Table Top		1 Pc	F	Drawer Front Panel		5 Pcs
B	Cabinet Left Panel		1 Pc	G	Drawer Right Panel		5 Pcs
C	Cabinet Right Panel		1 Pc	H	Drawer Left Panel		5 Pcs
D	Cabinet Back Panel		1 Pc	I	Drawer Back Panel		5 Pcs
E	Drawer Bottom Board		5 Pcs	J	Drawer Inner Bone		3 Pcs
				K	Drawer Outer Bone		2 Pcs

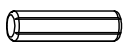
HARDWARE LIST

No.	Description	Sketch	Size	Quantity	No.	Description	Sketch	Size	Quantity
1	Drawer Runner Slide		Standard	5 Sets	6	Wooden Handle			5 Pcs
2	Dowel		24x8.5	34 Pcs	7	Handle Screw		M4x22	5 Pcs
3	Ultra Shallow Cam		15x9.5	34 Pcs	8	Chipboard Screw		M3.5x12	40 Pcs
4	CSK Cap Wood Screw		M6x40	20 Pcs	9	Panel Screw (Black)		M3.5x12	30 Pcs
5	Wood Dowel		8x30	20 Pcs	10	Allen Key		M4	1 Pc

ASSEMBLY INSTRUCTIONS





Item No : W1596102258

Description : CHEST

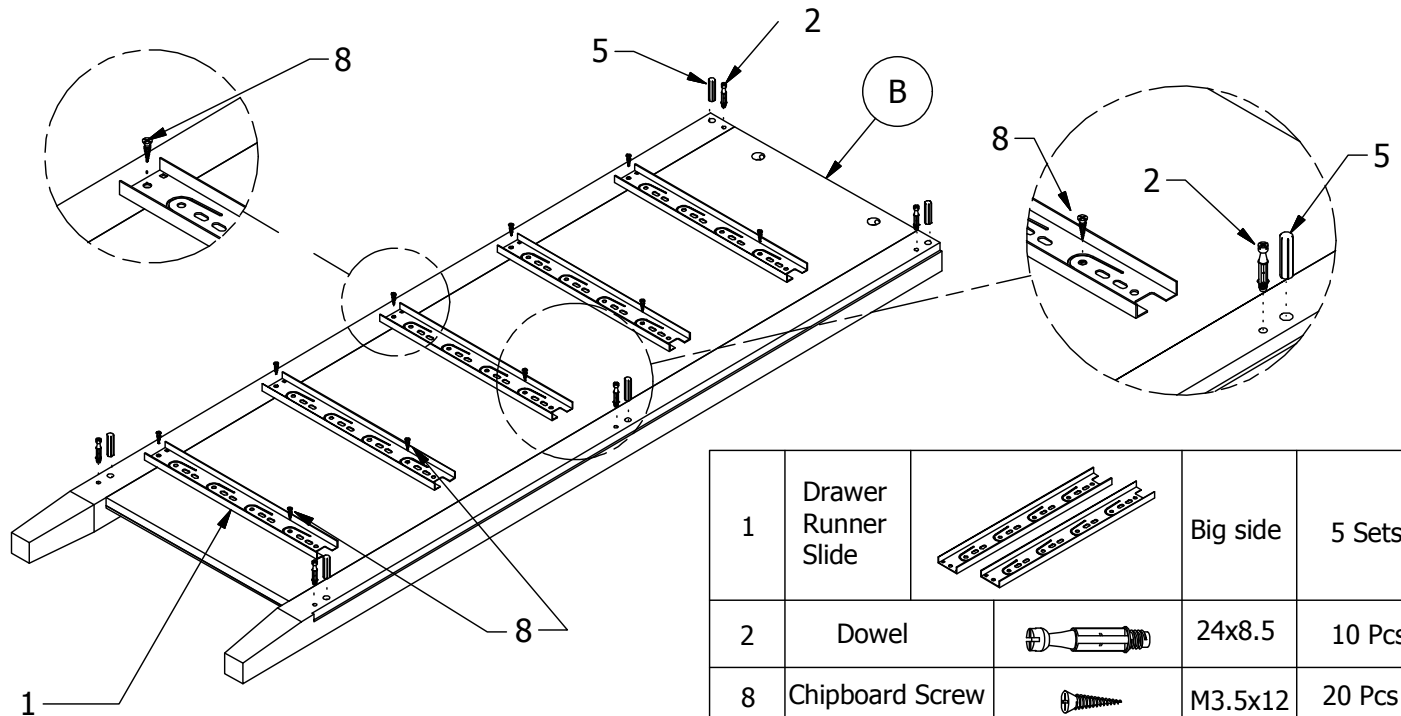
Thank you for purchasing this quality product. Be sure to check all packing material carefully for small part that may have come loose inside the carton during shipment .

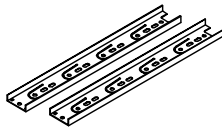
Step 1: Prepare the Cabinet Right Panel (B) & Cabinet Left Panel (C) then assemble the Drawer Runner Slide (1) on the pre-drilled holes with Chipboardboard Screw (8).



1	Drawer Runner Slide		Big side	5 Sets
2	Dowel		24x8.5	10 Pcs
8	Chipboard Screw		M3.5x12	20 Pcs
5	Wood Dowel		8x30	10 Pcs

Step 2: Attach the Drawer Inner Bone (J) & Drawer Outer Bone (K) with Ultra Shallow Cam (3) to ready the cabinet structure as picture shown. ▽

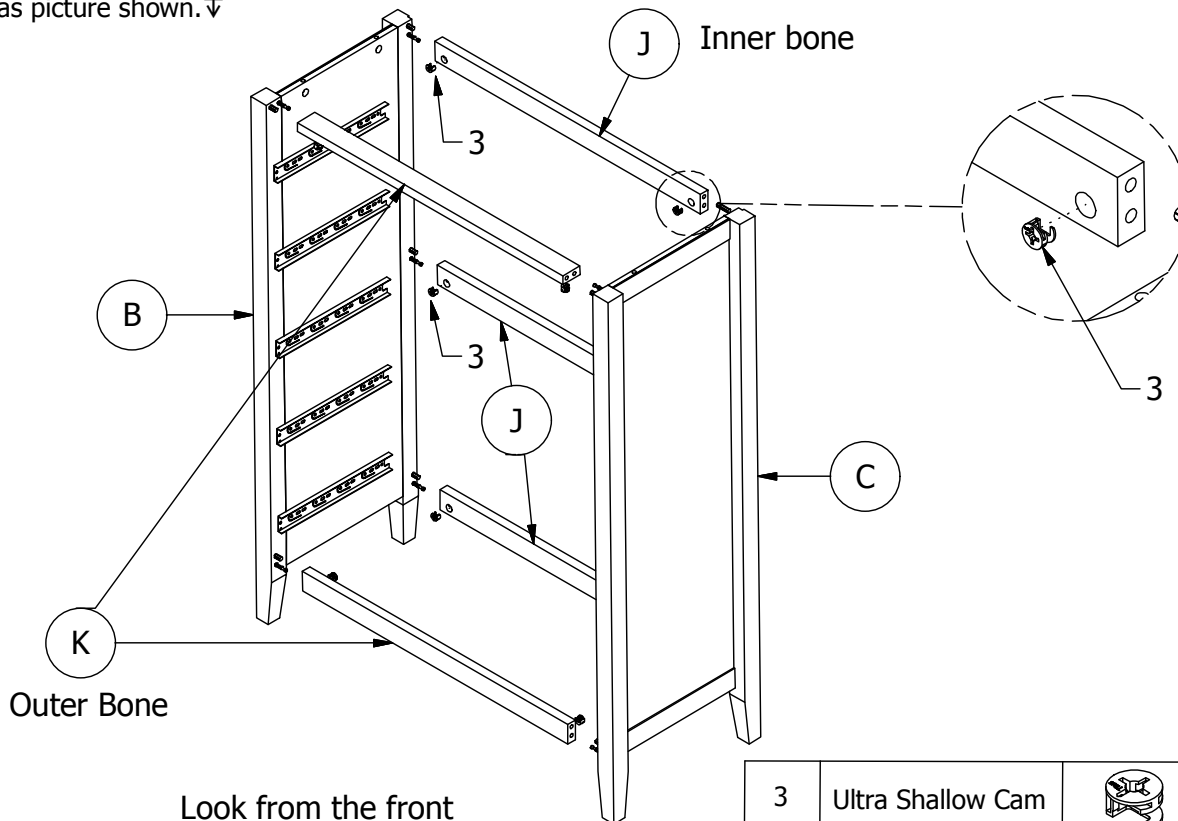

3	Ultra Shallow Cam		15x9.5	10 Pcs
---	-------------------	---	--------	--------

ASSEMBLY INSTRUCTIONS

Item No : W1596102258

Description : CHEST

Thank you for purchasing this quality product . Be sure to check all packing material carefully for small part that may have come loose inside the carton during shipment .

Step 3: Insert the Dowel (2) onto the pre-drilled holes on the bottom part of Table Top (A).

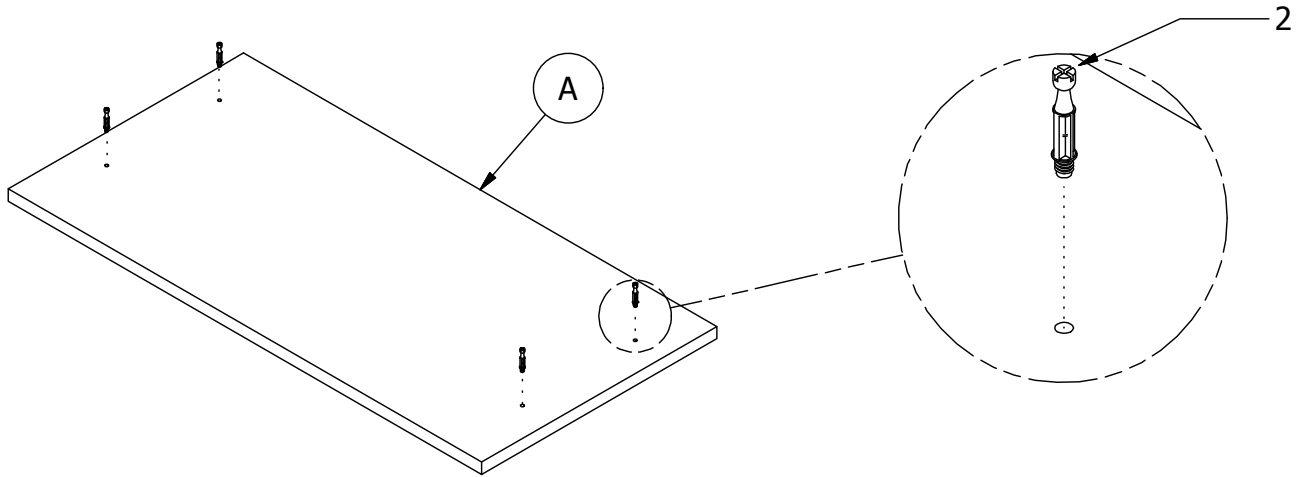

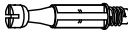
2	Dowel		24x8.5	4 Pcs
---	-------	---	--------	-------

Step 4: Ready the cabinet structure and flip the Table Top (A) to cover on top of the cabinet. Then tighten the attachment with Ultra Shallow Cam (3) to the Dowel pre-installed in previous step 3. You would need to ready a screwdriver to perform this step.

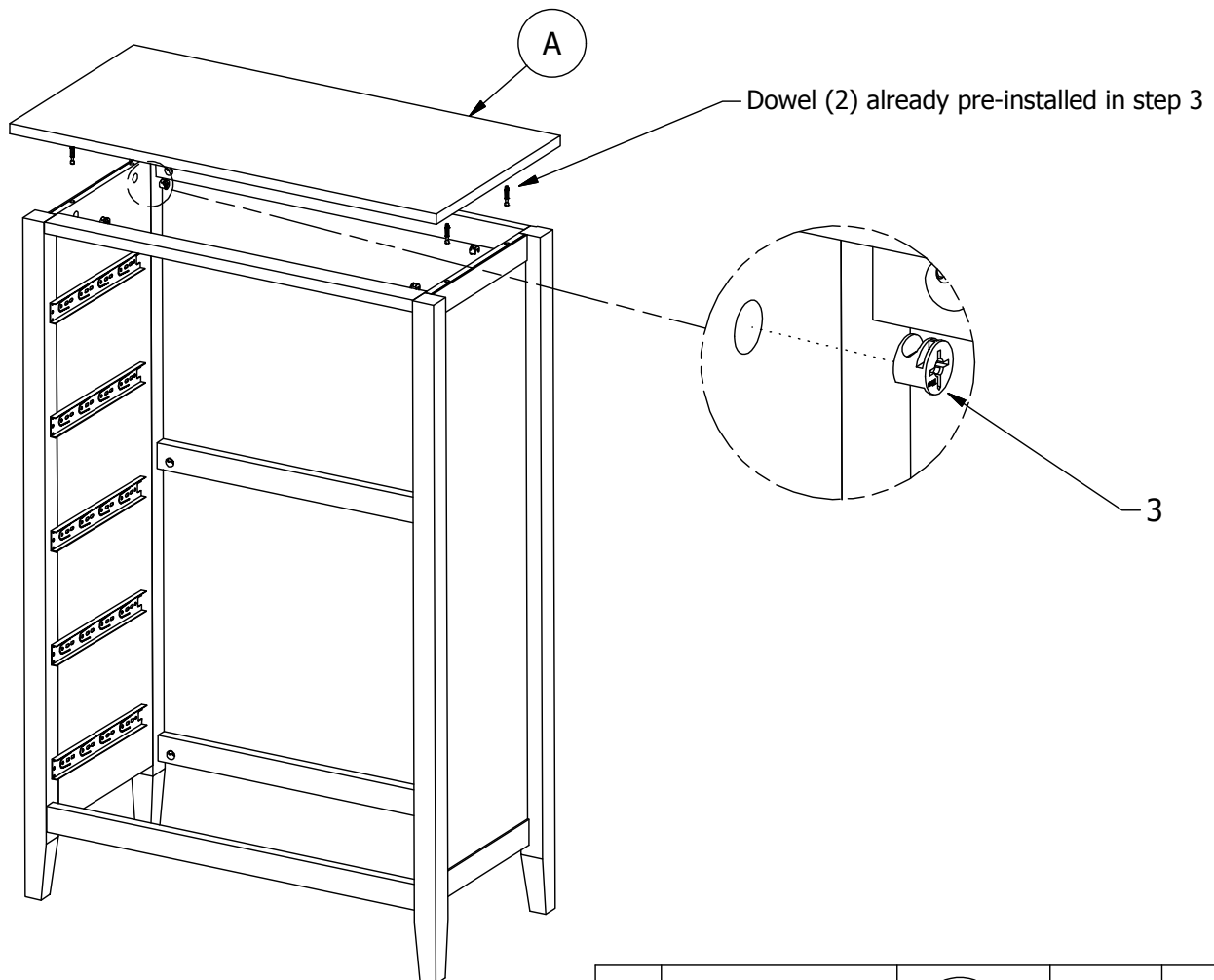

3	Ultra Shallow Cam		15x9.5	4 Pcs
---	-------------------	---	--------	-------

ASSEMBLY INSTRUCTIONS

Item No : W1596102258

Description : CHEST

Thank you for purchasing this quality product . Be sure to check all packing material carefully for small part that may have come loose inside the carton during shipment .

Important: Wood Dowel (5) ONLY to be inserted on pre-drilled holes of Drawer Right & Left Panel (G & H)

Step 5: Lay the Drawer Front Panel (F) on even-layered flat surface, put in the Dowel (2) on each side and take the Drawer Panel (G & H) insert into the Pre-drilled holes of the Front Panel, tighten the part with Ultra Shallow Cam (3). Next, slide in the Drawer Bottom Board (E) finish up with screwing the Wooden Handle (6) with using Handle Screw (7).

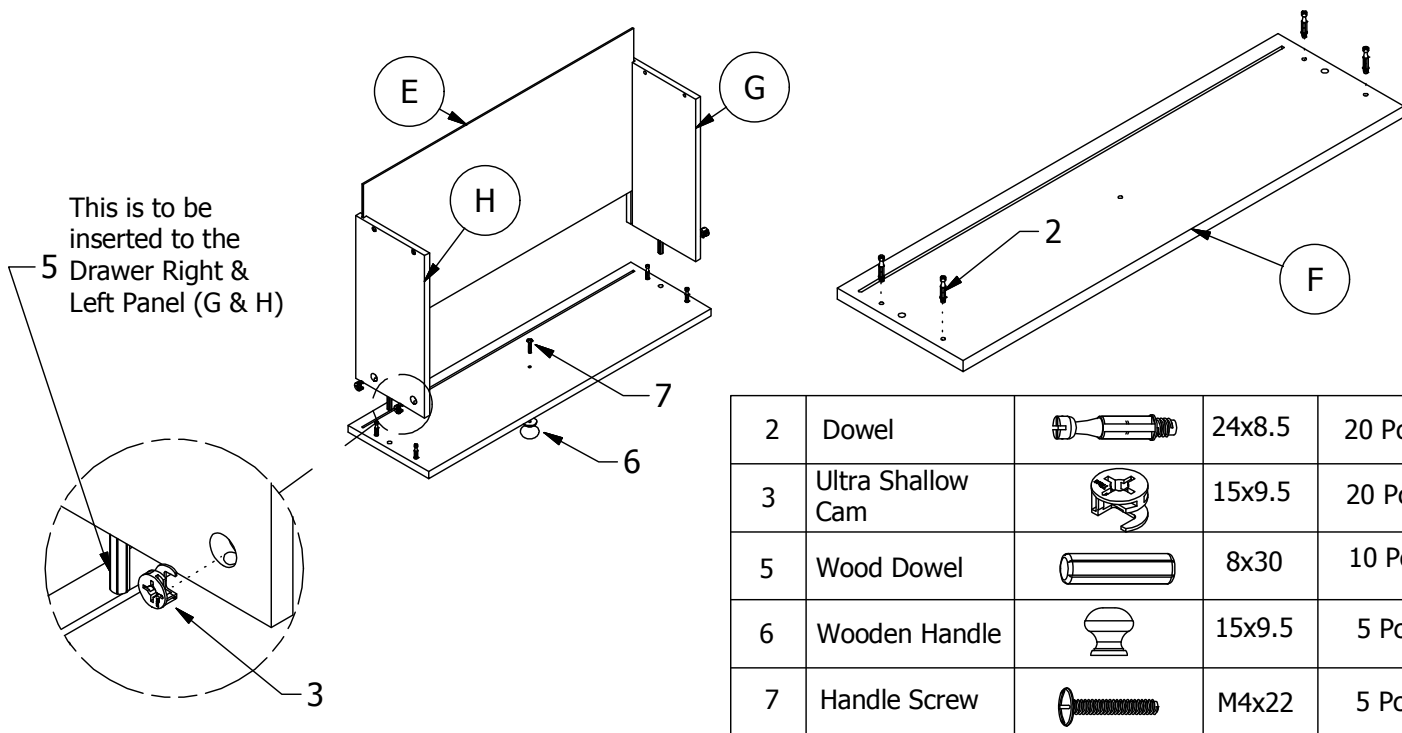

Step 6: Setting up the Drawer with its Drawer Back Panel (I) with CSK Cap Screw (4) with the help of Allen Key (10). Assemble the Drawer Runner Slide (1) to the Drawer Panel (G & H) by using Chipboard Screw (8).

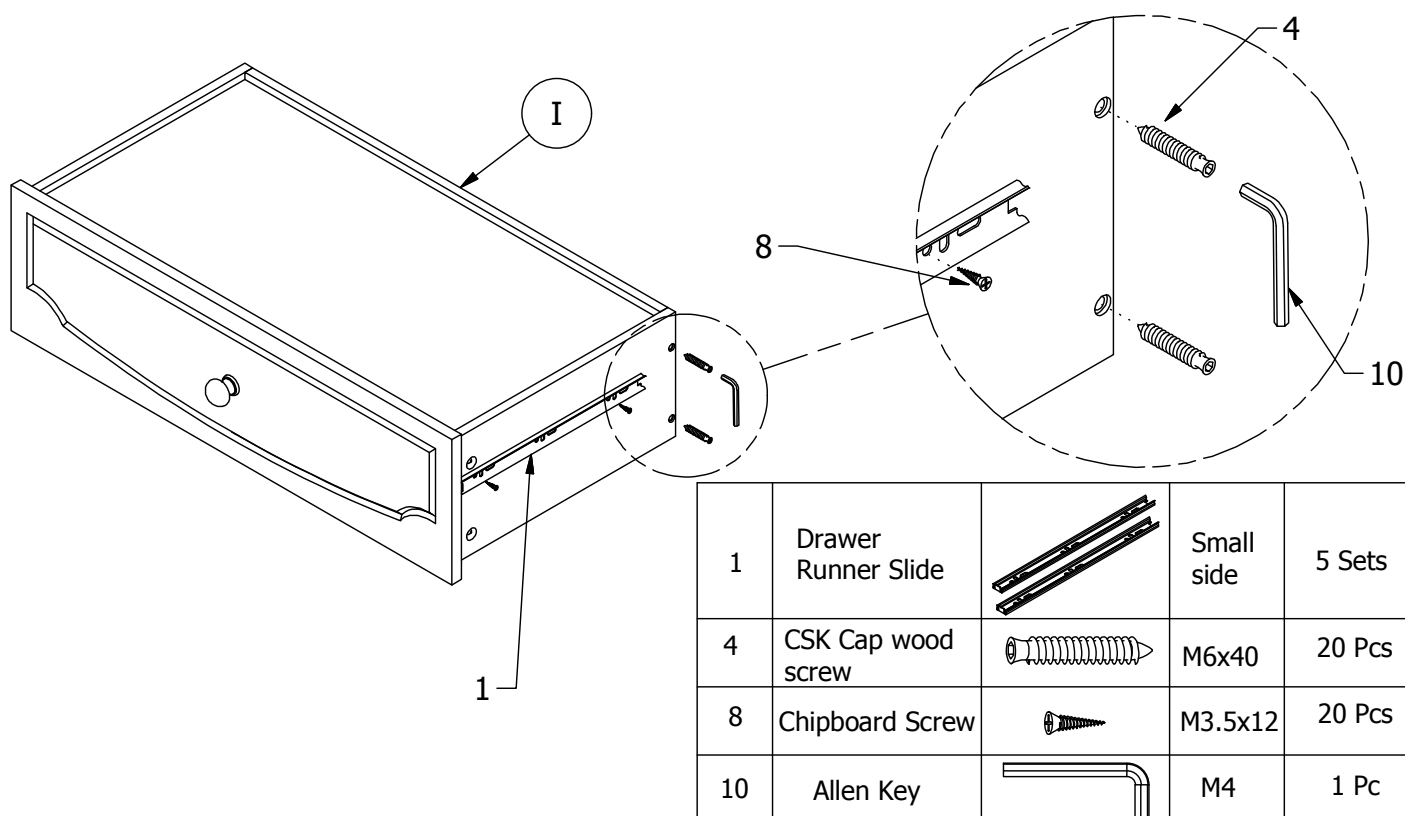

ASSEMBLY INSTRUCTIONS

Item No : W1596102258

Description : CHEST

Thank you for purchasing this quality product . Be sure to check all packing material carefully for small part that may have come loose inside the carton during shipment .

Step 7: Cover up the back of cabinet with Cabinet Back Panel (D) by using Panel Screw (Black) (9).

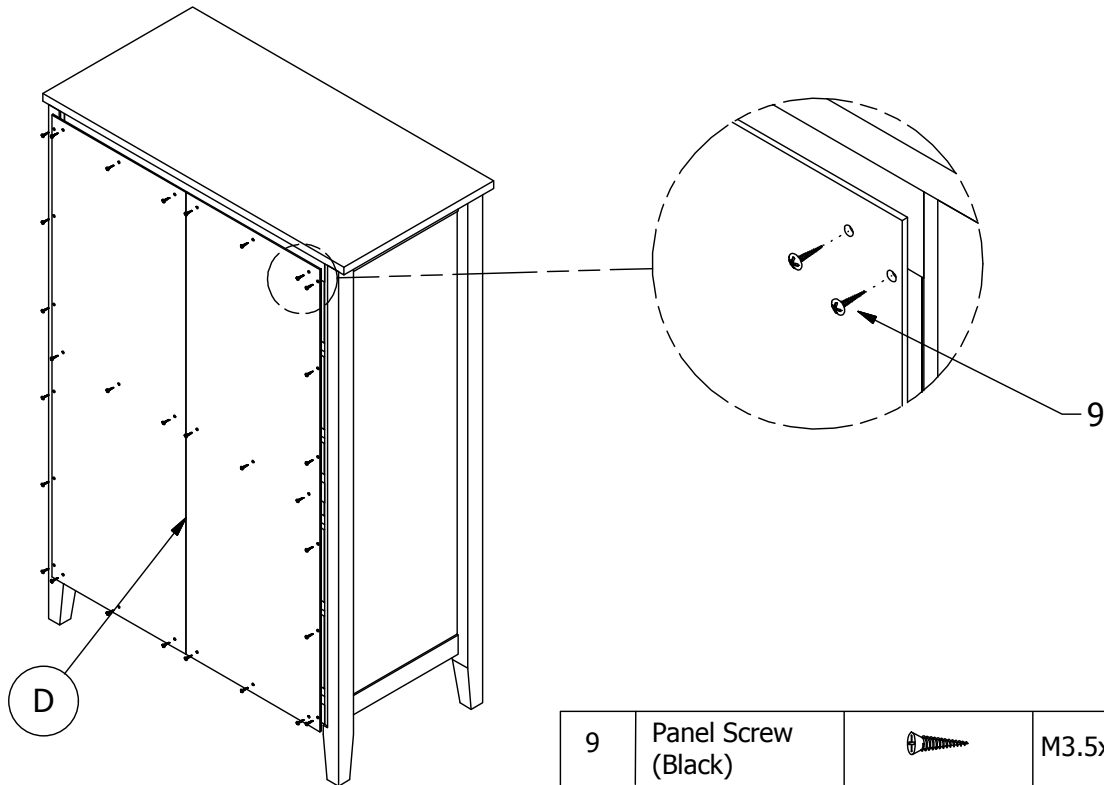

9	Panel Screw (Black)		M3.5x12	30 Pcs
---	------------------------	---	---------	--------

Finally, insert the drawers assembled like picture shown below and the Chest is done Assembled.
** Drawers should glide in-to the runner, not sitting on top of the runner.

