

ASSEMBLY INSTRUCTION

6 PCS RATTAN SOFA SET

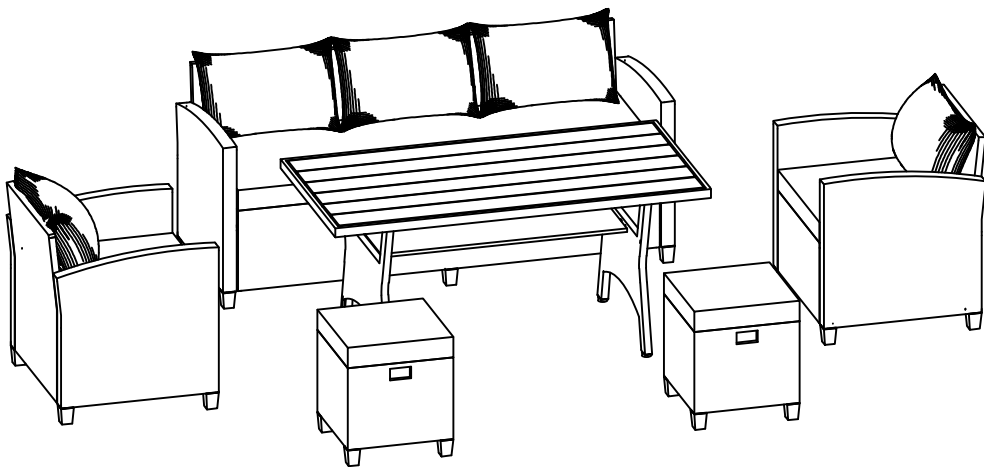

WF300003,WF300004,WF300005

x1

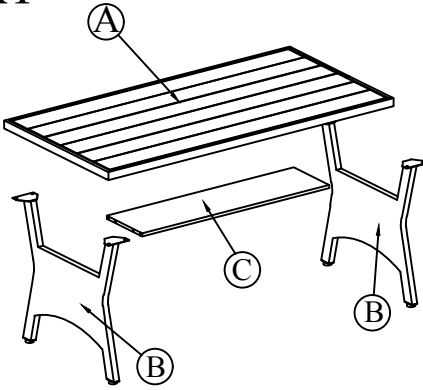

x2

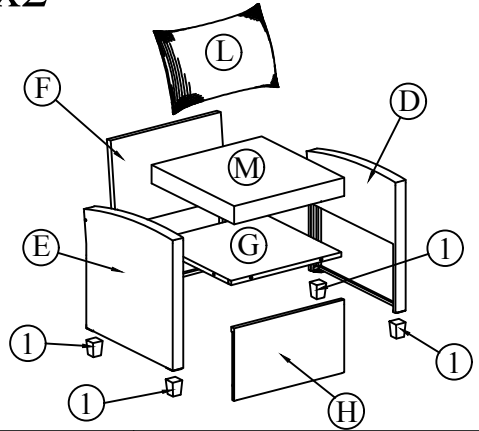

x1

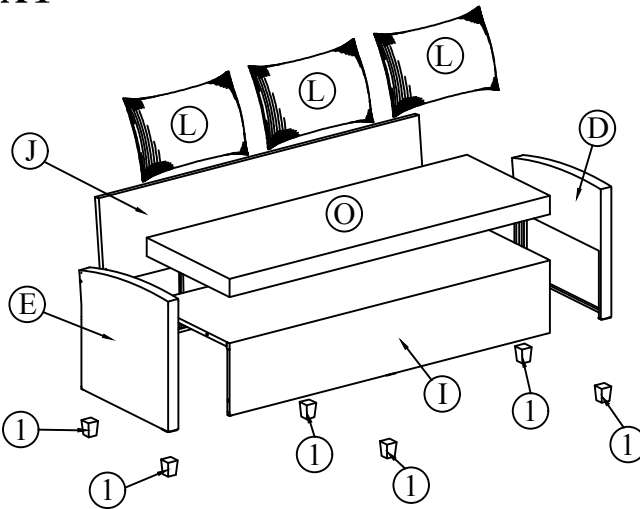

x2

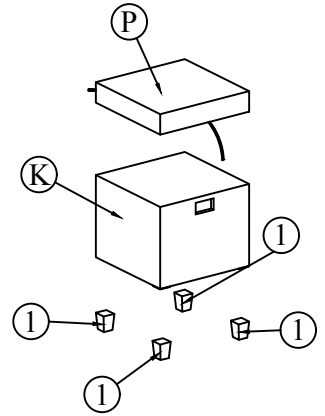

Note:

1. 50% Tighten before fixing all screws, Allen wrench is recommended instead of an electric drill.
2. Place the item on a flat ground to adjust and make sure it remains stable.
3. Tighten up all screw with tools gradually.
4. If screw are not aligned with holes during assembly, please loosen all the other screws to 50% and continue the assembly process.
5. If the item is not stable, please loosen all screws, adjust it on a flat ground and tighten up all screws again.
6. Note: If one or some screws are fully tighten during assembly, chances are the others will not be aligned with holes. In addition, all the holes are designed to be relatively larger to provide more space for the adjustment of the screws.

CARTON CONTENT:

WF300003

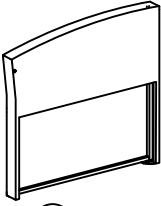

Ⓓx3

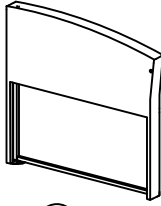

Ⓔx3

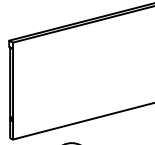

Ⓕx2



Hardware

WF300004

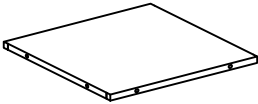

Ⓖx2

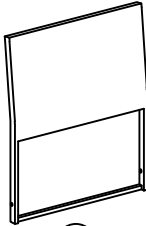

Ⓕx2

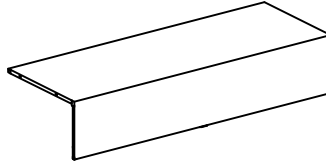

Ⓖx1

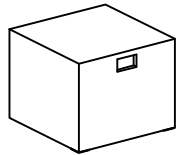

Ⓖx2

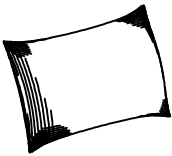

Ⓖx5

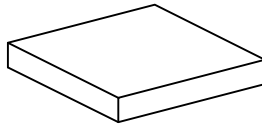

Ⓖx2

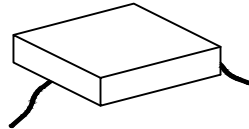

Ⓖx2

WF300005

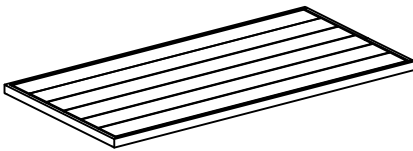

Ⓐx1

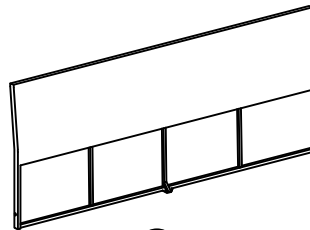

Ⓖx1

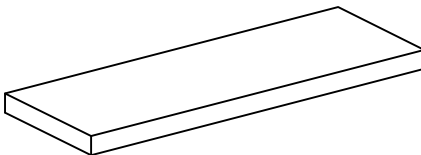

Ⓖx1





Ⓖx2







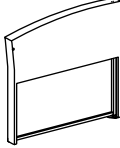
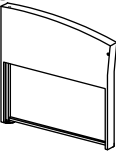
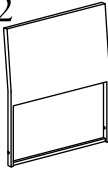
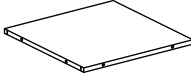
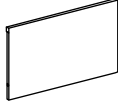
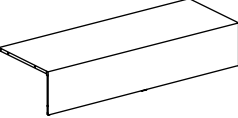
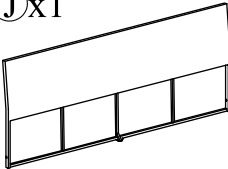
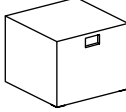
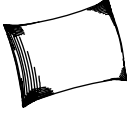
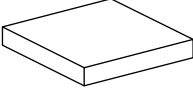
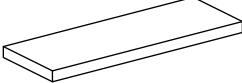
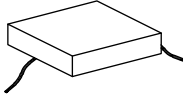



Ⓖx1

PART LIST:

<p>Ax1</p>  <p>Top Table</p>	<p>Bx2</p>  <p>Leg Table</p>	<p>Cx1</p>  <p>Front Table</p>	<p>Dx3</p>  <p>Arm Left</p>
<p>Ex3</p>  <p>Arm Right</p>	<p>Fx2</p>  <p>Back Chair</p>	<p>Gx2</p>  <p>Seat Chair</p>	<p>Hx2</p>  <p>Front Chair</p>
<p>Ix1</p>  <p>Seat Bench</p>	<p>Jx1</p>  <p>Back Bench</p>	<p>Kx2</p>  <p>Stool</p>	<p>Lx5</p>  <p>Back Cushion</p>
<p>Mx2</p>  <p>Seat Chair Cushion</p>	<p>Ox1</p>  <p>Seat Bench Cushion</p>	<p>Px2</p>  <p>Seat Stool</p>	

Hardware List:

<p>1 x 22 Pcs</p>  <p>Leg Sofa</p>	<p>2 x 8 Pcs Extra 1 pcs</p>  <p>BOLT M8 x 20MM</p>	<p>3 x 16 Pcs Extra 2 pcs</p>  <p>BOLT M6 x 30MM</p>	<p>4 x 24 Pcs Extra 2 pcs</p>  <p>BOLT M6 x 40MM</p>	
<p>5 x 22 Pcs Extra 2 pcs</p>  <p>BOLT M6 x 55MM</p>	<p>6 x 6 Pcs Extra 1 pcs</p>  <p>BOLT M6 x 70MM</p>	<p>7 x 46 Pcs Extra 8 pcs</p>  <p>FLAT WASHER M6</p>	<p>8 x 2 Pcs</p>  <p>ALLEN KEY</p>	<p>9 x 8 Pcs Extra 1 pcs</p>  <p>FLAT WASHER M8</p>

STEP 1

- (A) x1
- (B) x2
- (2) x8
- (9) x8

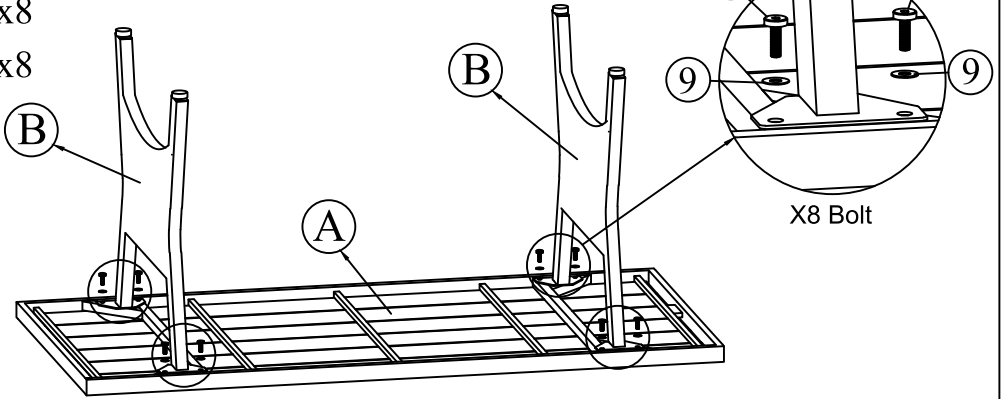

Connect The Top Table (A) & Leg Table (B), tighten Allen Bolt (2), Flat Washer (7), with Allen Key (8).

STEP 2

- (C) x1
- (3) x4
- (7) x4

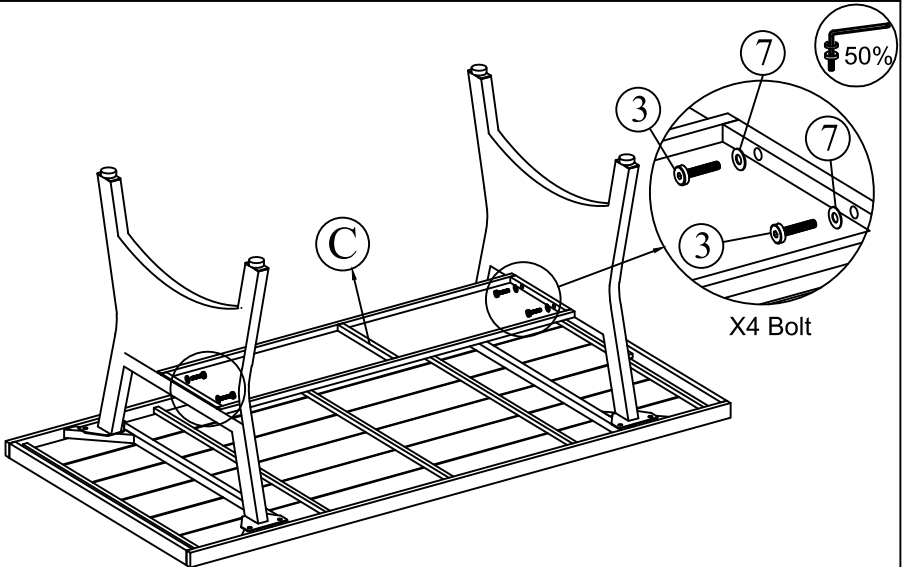

Connect The Part from STEP 1 & Front Table (C), tighten Allen Bolt (3), Flat Washer (7), with Allen Key (8).

STEP 3

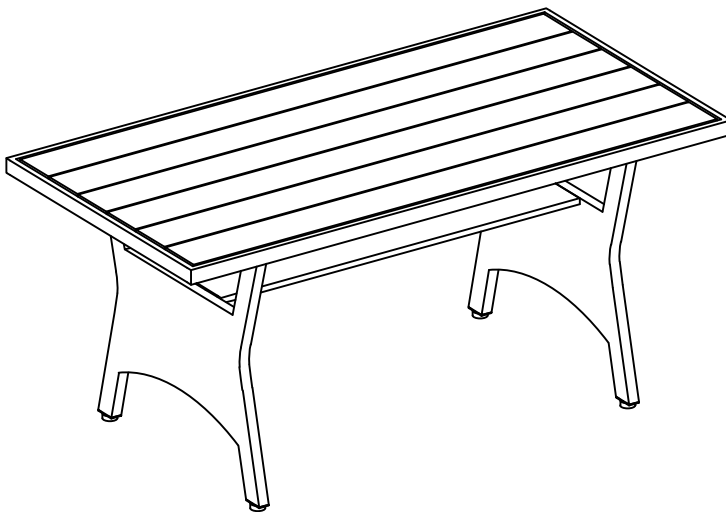

Put the Table upright and make sure all legs are level, then firmly tighten Bolts with Allen Key (8)

STEP 4



- ⓓ x1
- ⓕ x1
- ③ x1
- ⑥ x1
- ⑦ x2

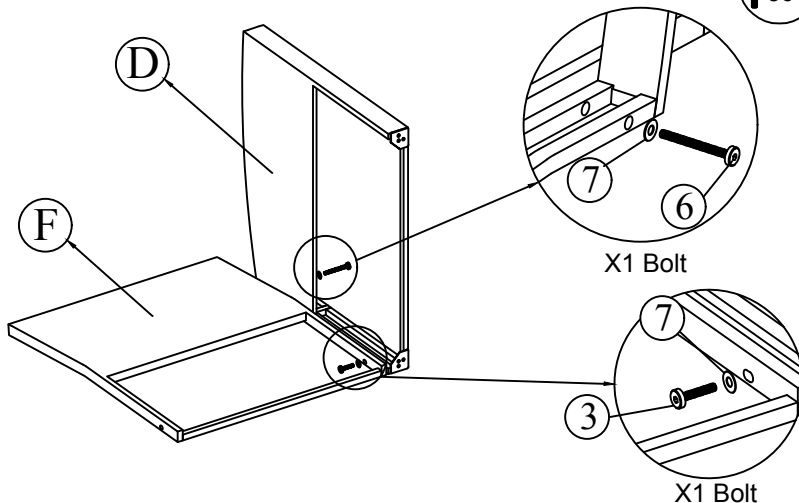

Connect The Arm Left (D) & Back Chair (F), tighten Allen Bolt (3),(6) Flat Washer (7), with Allen Key (8).

STEP 5

- (E) x1
- (3) x1
- (6) x1
- (7) x2

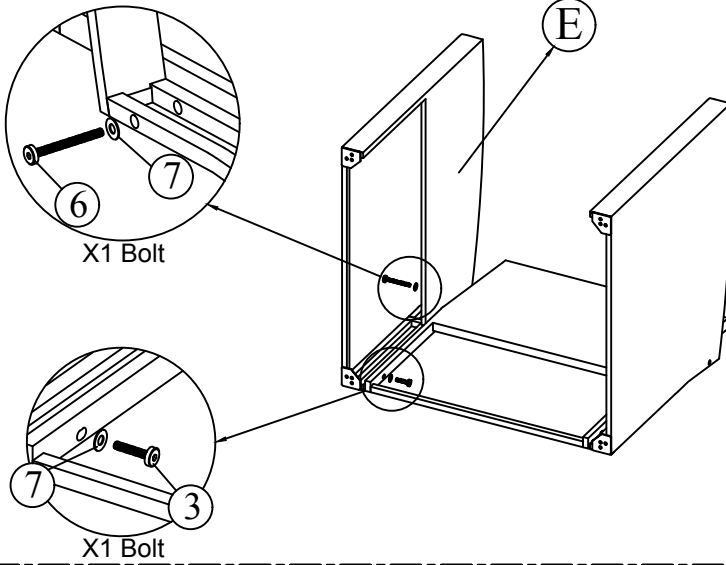

Connect The Part from STEP 4 & Arm Right (E), tighten Allen Bolt (3),(6) Flat Washer (7), with Allen Key (8).

STEP 6

- (G) x1
- (4) x6
- (7) x6

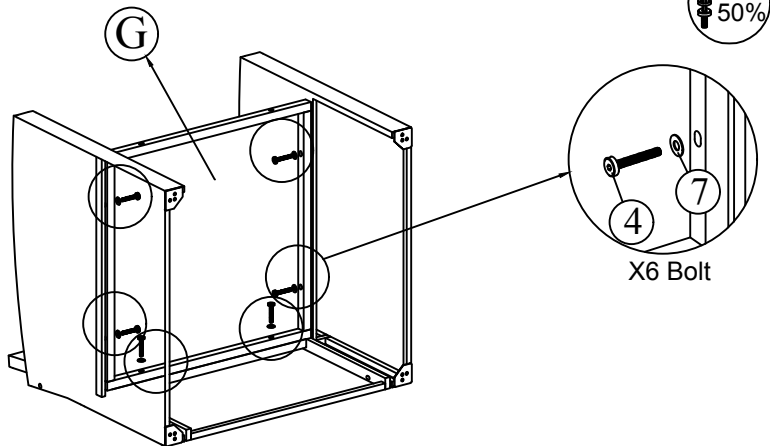

Connect The Part from STEP 5 & Seat Chair (G), tighten Allen Bolt (4), Flat Washer (7), with Allen Key (8).

STEP 7

- ⓗ x1
- ③ x2
- ④ x2
- ⑦ x4

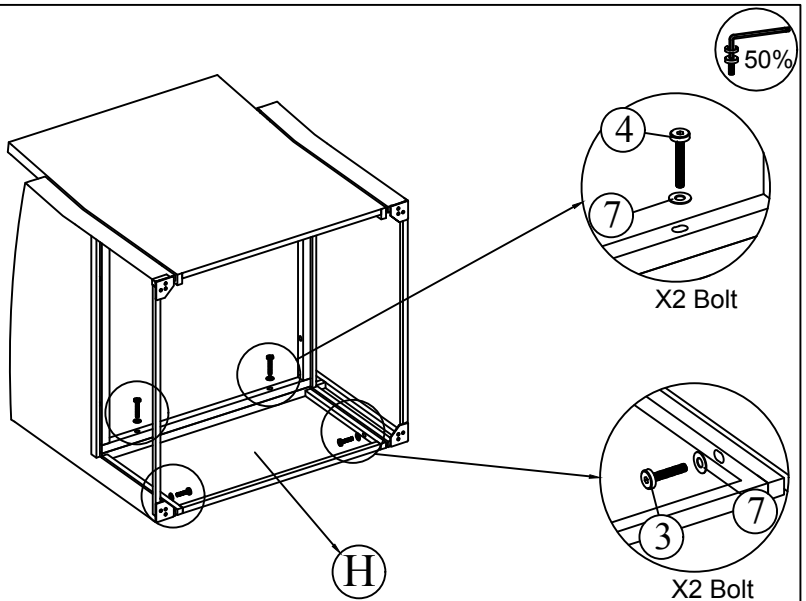

Connect The Part from STEP 6 & Front Chair (H), tighten Allen Bolt (3),(4) Flat Washer (7), with Allen Key (8).

STEP 8

- ① x4
- ⑤ x4

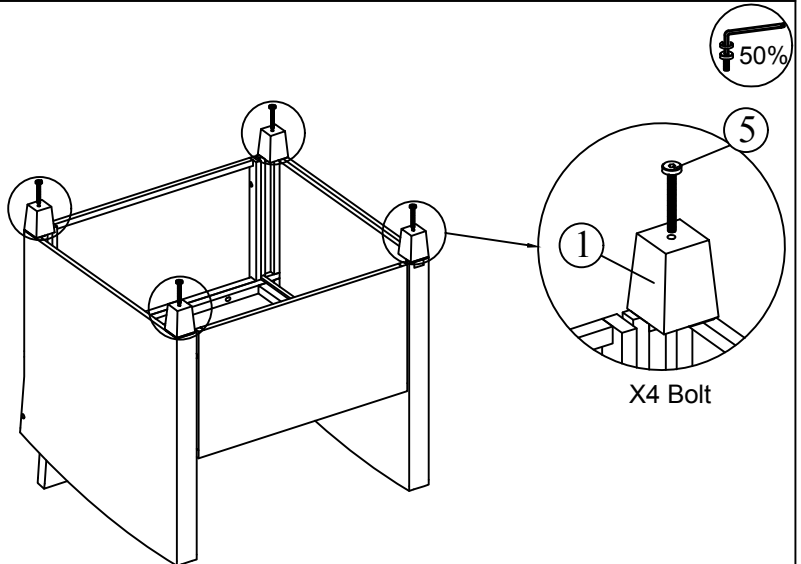

Connect The Part from STEP 7 & Leg Sofa (1), tighten Allen Bolt (5), with Allen Key (8).

STEP 9

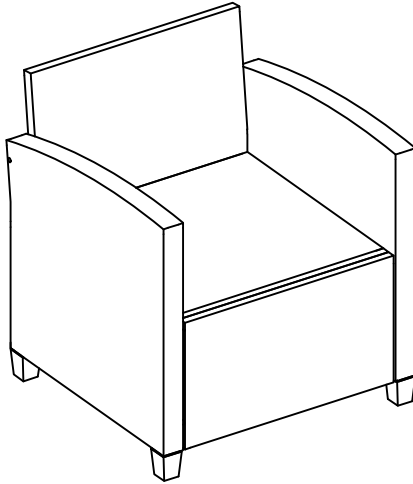

Put the Chair upright and make sure all legs are level, then firmly tighten Bolts with Allen Key (8)

STEP 10

(M)x1

(L)x1

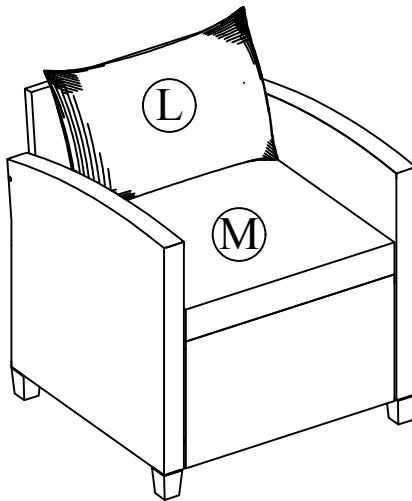

Put on Seat Chair Cushion (M), Back Cushion (L) to finish Chair.

STEP 11

- (D)x1
- (J)x1
- (3)x1
- (6)x1
- (7)x2

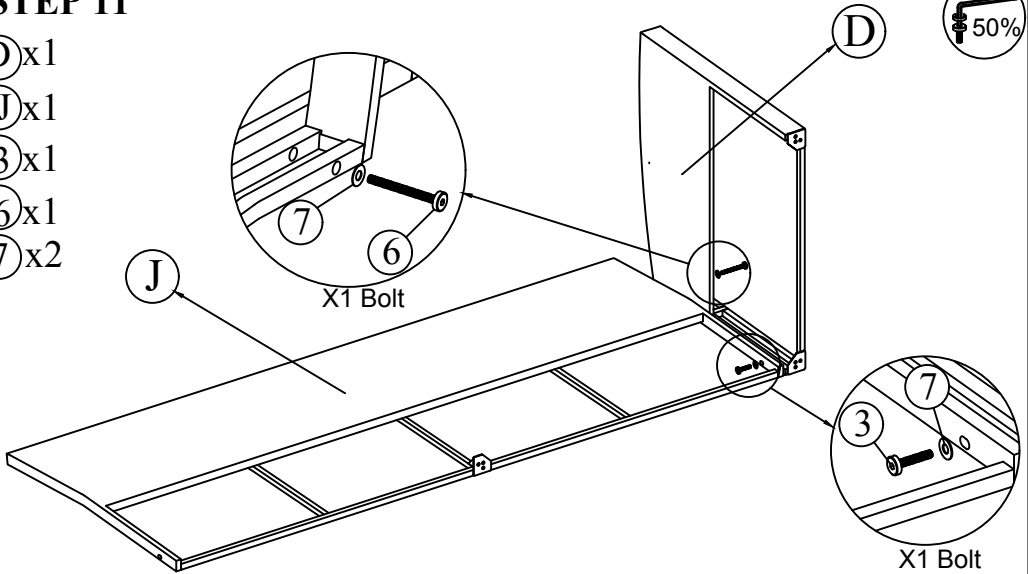

Connect The Arm Left (D) & Back Bench (J), tighten Allen Bolt (3),(6), Flat Washer (7) with Allen Key (8).

STEP 12

- (E)x1
- (3)x1
- (6)x1
- (7)x2

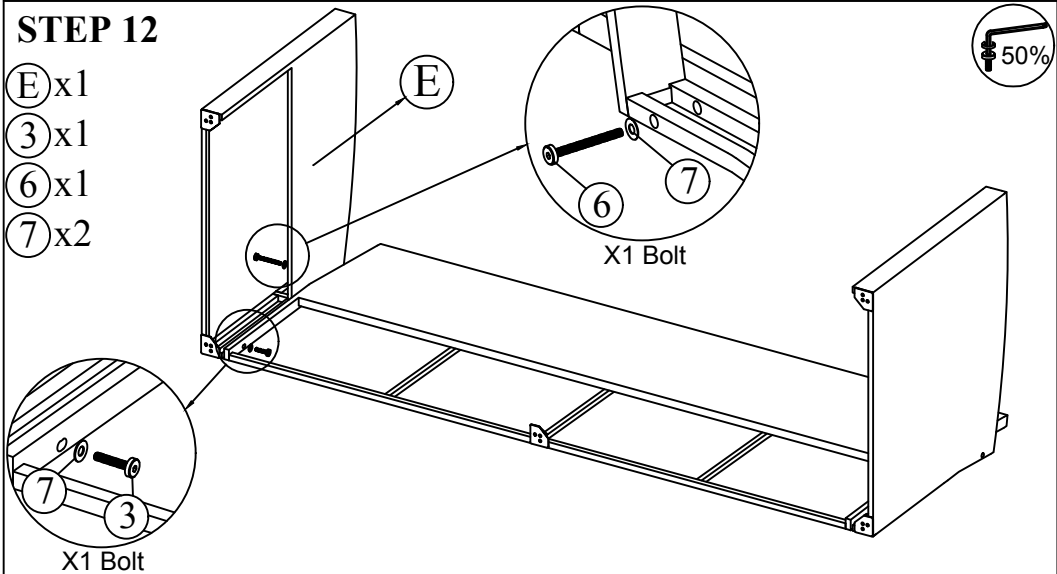

Connect The Part from STEP 11 & Arm Right (E) , tighten Allen Bolt (3),(6) , Flat Washer (7) with Allen Key (8).

STEP 13

- ① x1
- ③ x1
- ④ x6
- ⑦ x7

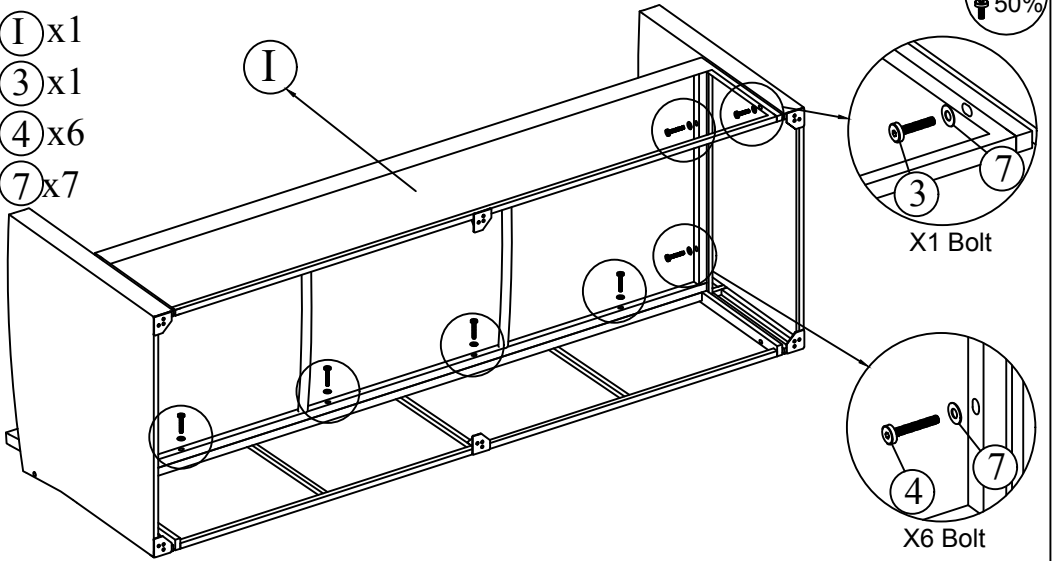

Connect The Part from STEP 12 & Seat Bench (I), tighten Allen Bolt (3),(4), Flat Washer (7), with Allen Key (8).

STEP 14

- ③ x1
- ④ x2
- ⑦ x3

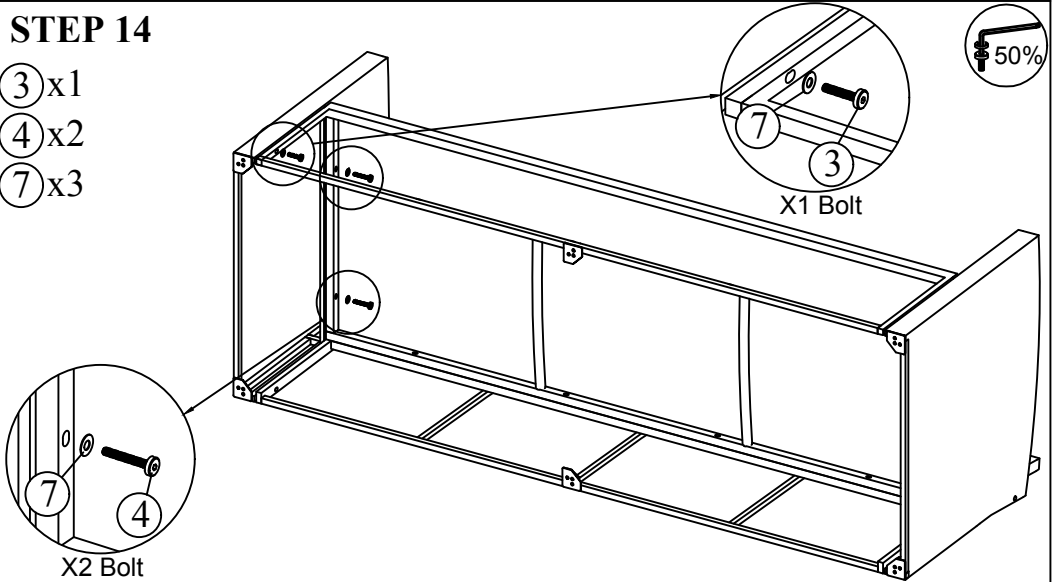

Connect The Part from STEP 13 , tighten Allen Bolt (3),(4), Flat Washer (7), with Allen Key (8).

STEP 15

① x6

⑤ x6

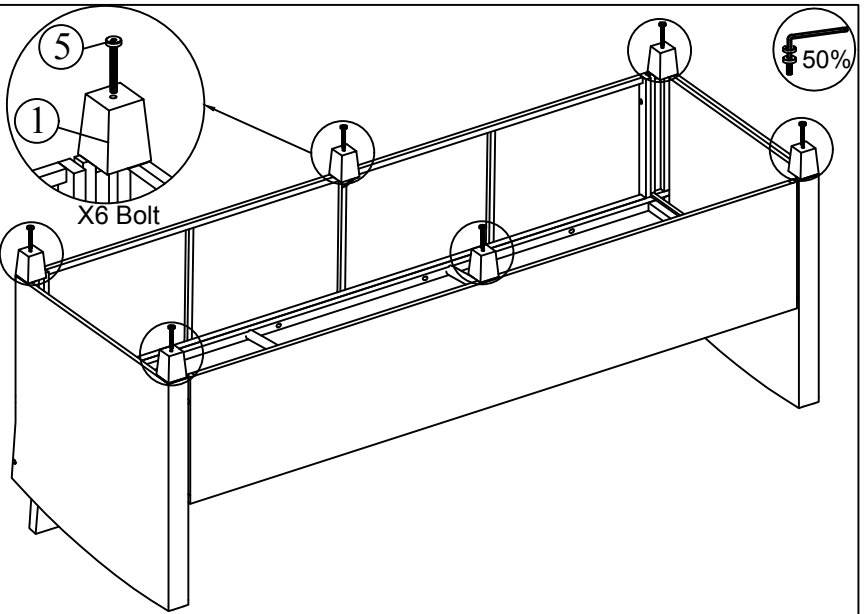

Connect The Part from STEP 14 & Leg Sofa (1), tighten Allen Bolt (5), with Allen Key (8).

STEP 16

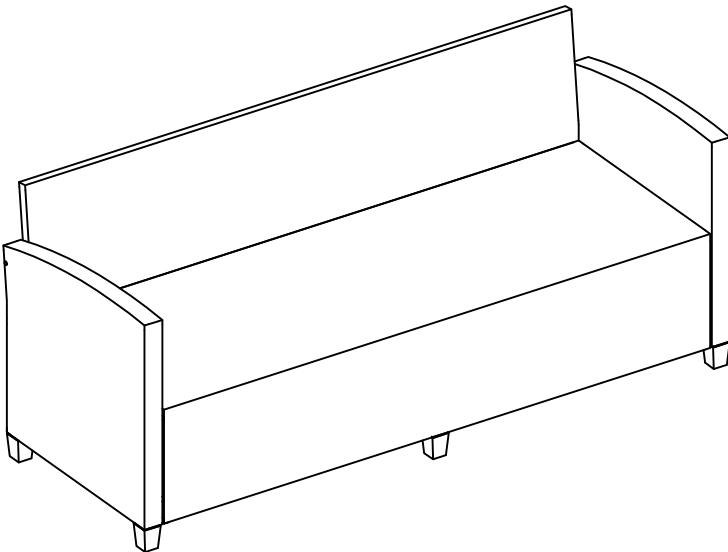

Put the Bench upright and make sure all legs are level, then firmly tighten Bolts with Allen Key (8)

STEP 17

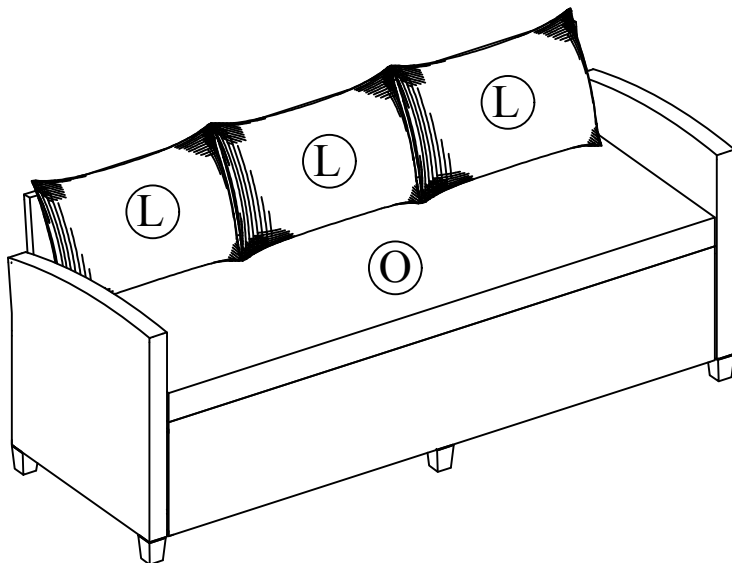

Put on Seat Bench Cushion (O), Back Cushion (L) to finish Bench.

STEP 18

- Ⓚ x1
- ① x4
- ⑤ x4

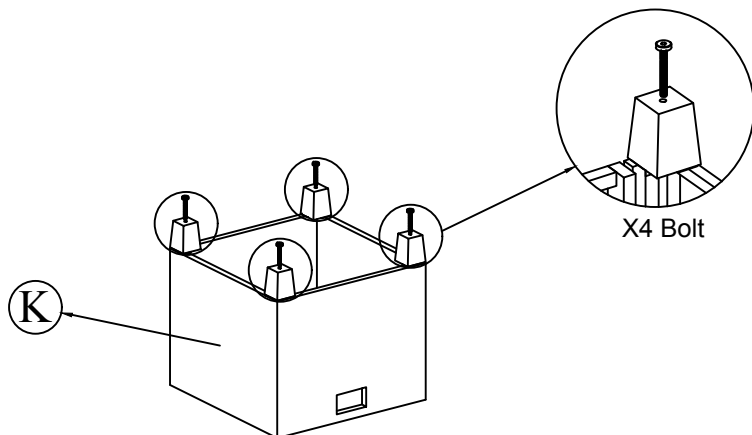

Connect The STool & Leg Sofa (1), tighten Allen Bolt (5), with Allen Key (8).

STEP 19

(P) x1

(P)

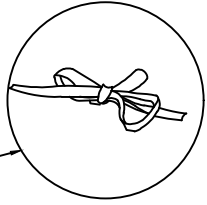
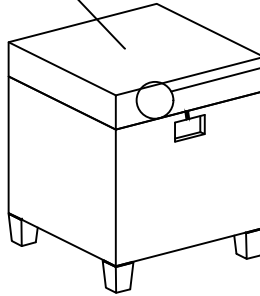

Put on Seat Stool (P) to finish Bench.

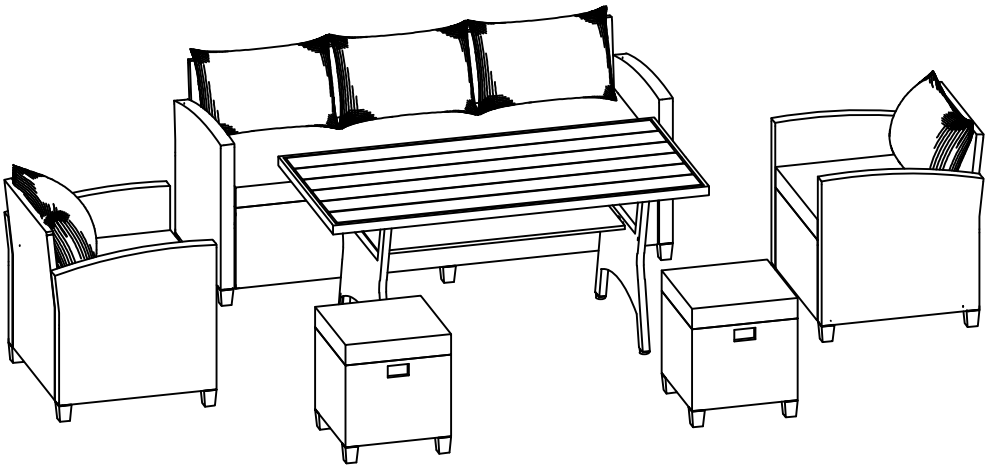

FINISH SOFA