

ASSEMBLY INSTRUCTION

RATTAN FURNITURE

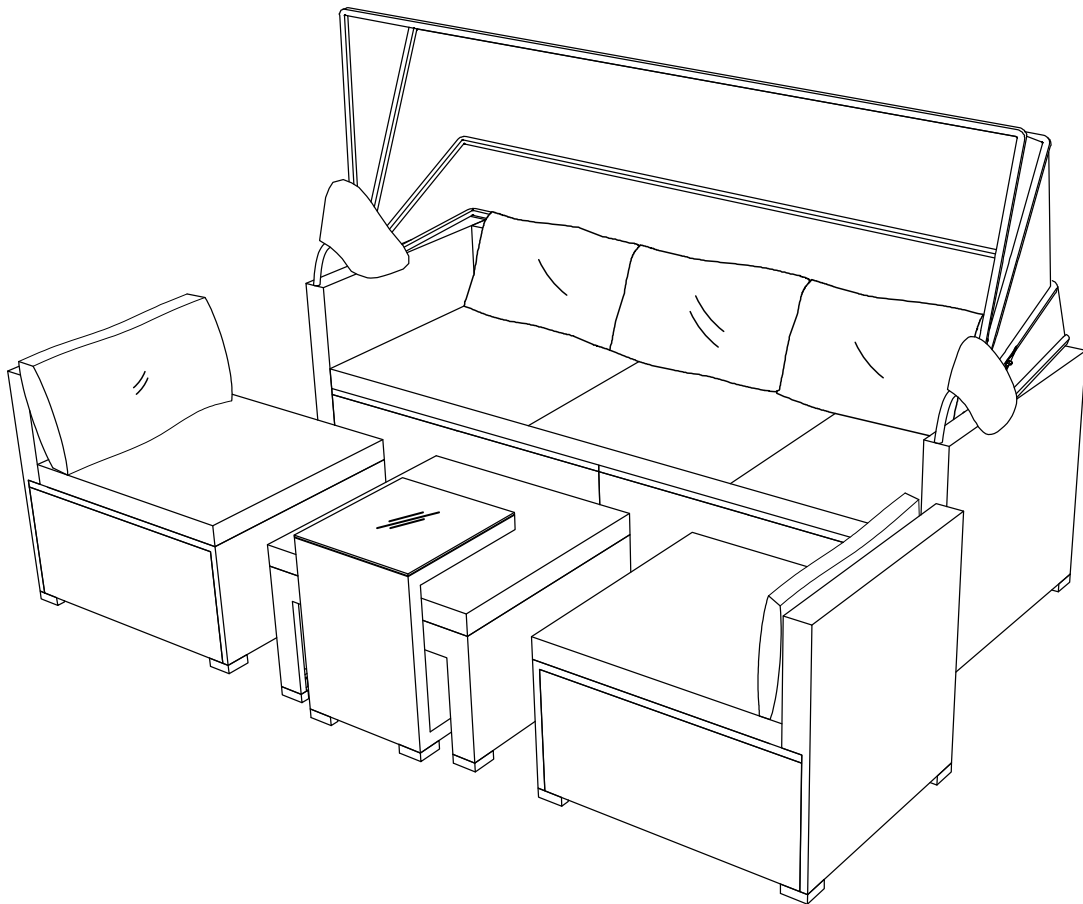

WF301544; WF301545; WF301546

Notice:

1. 50% Tighten before fixing all screws, Allen wrench is recommended instead of an electric drill.
2. Place the item on a flat ground to adjust and make sure it remains stable.
3. Tighten up all screws with tools gradually.
4. If the screws are not aligned with holes during assembly, please loosen all the other screws to 50% and continue the assembly process.
5. If the item is not stable, please loosen all the screws, adjust it on a flat ground and tighten up all screws again.
6. Note : If one or some screws are fully tightened during assembly, chances are the others will not be aligned with holes. In addition, all the holes are designed to be relatively larger to provide more space for the adjustment of the screws.

Exploded View

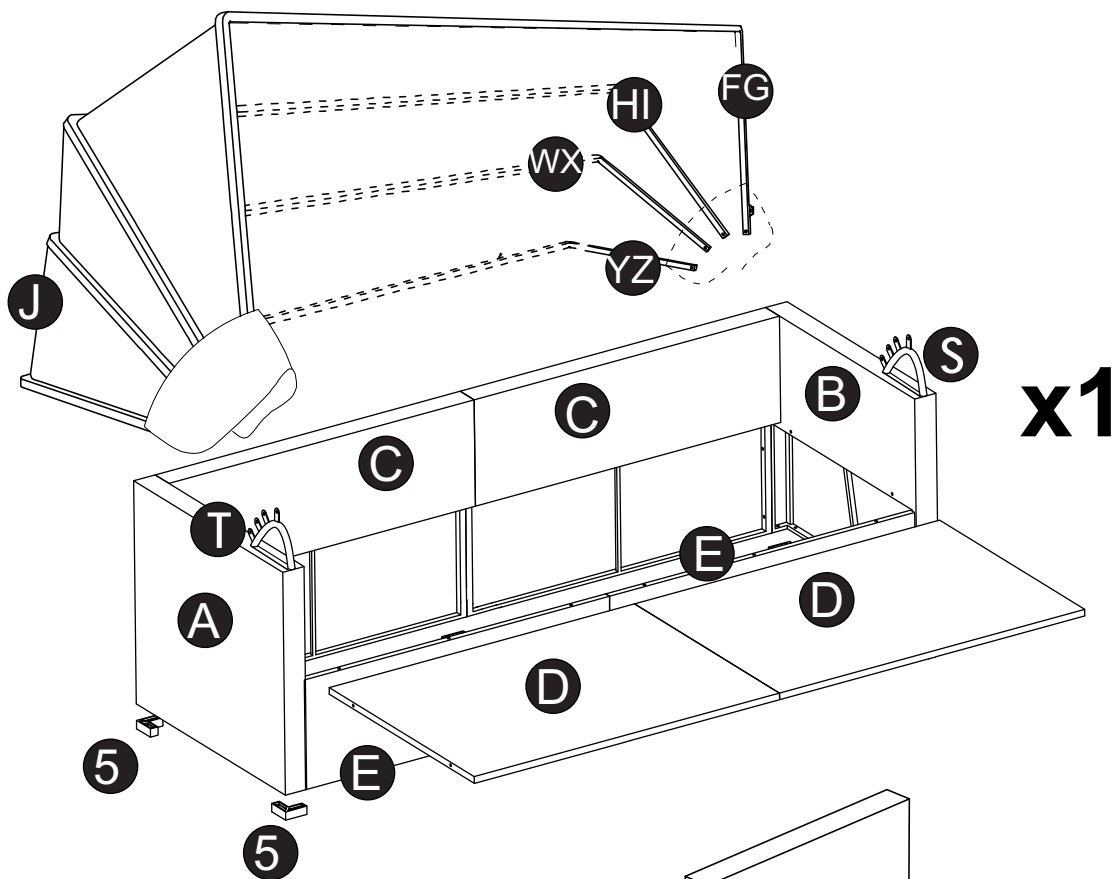



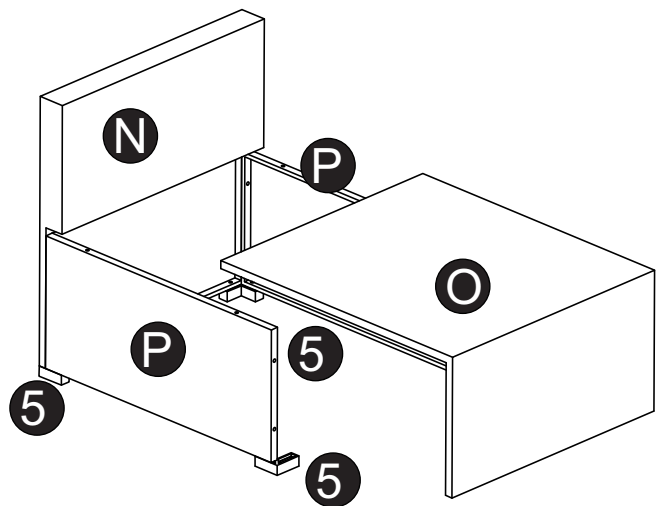

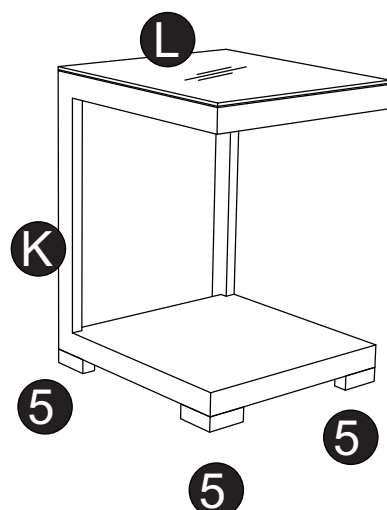
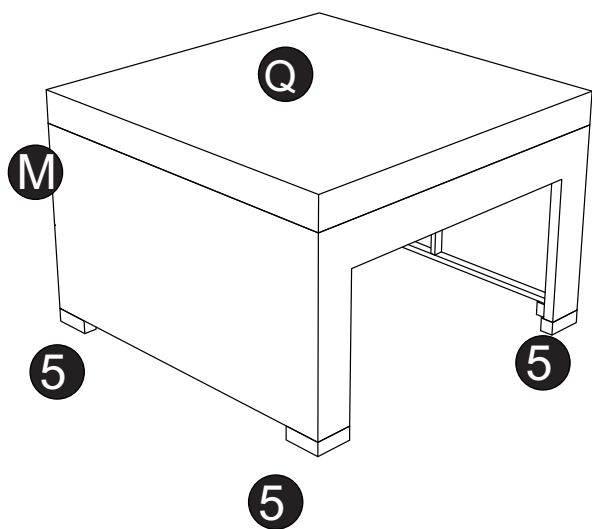

x2



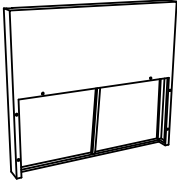
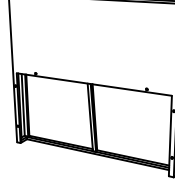
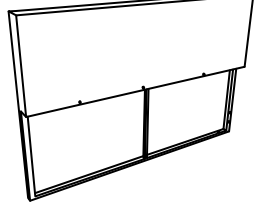
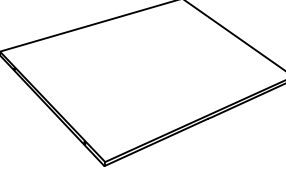
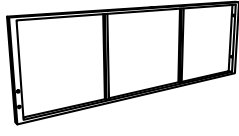
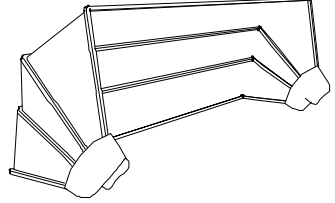
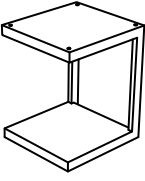

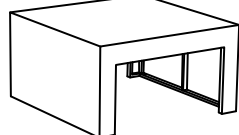
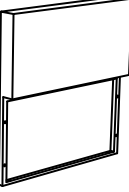
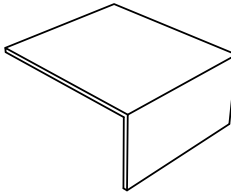
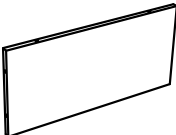
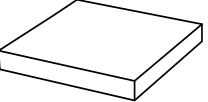







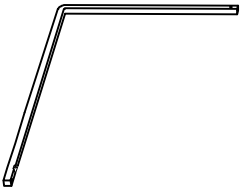
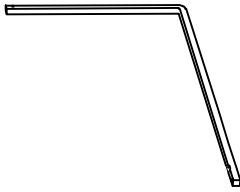
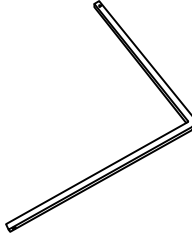
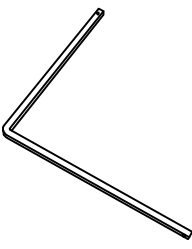
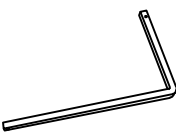
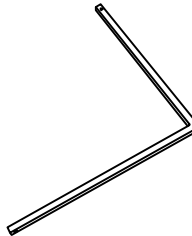
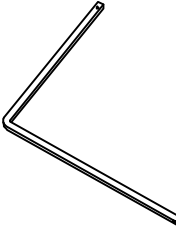
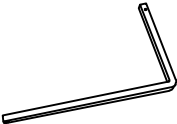

x1

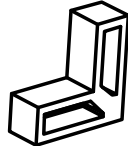

Part List and Hardware

<p>A</p>  <p>(1 PC)</p>	<p>B</p>  <p>(1 PC)</p>	<p>C</p>  <p>(2 PCS)</p>
<p>D</p>  <p>(2 PCS)</p>	<p>E</p>  <p>(2 PCS)</p>	<p>J</p>  <p>(1 PC)</p>
<p>K</p>  <p>(1 PC)</p>	<p>L</p>  <p>(1 PC)</p>	<p>M</p>  <p>(1 PC)</p>
<p>N</p>  <p>(2 PCS)</p>	<p>O</p>  <p>(2 PCS)</p>	<p>P</p>  <p>(4 PCS)</p>
<p>Q</p>  <p>(6 PCS)</p>	<p>R</p>  <p>(5 PCS)</p>	<p>S</p>  <p>(1 PC)</p>
<p>T</p>  <p>(1 PC)</p>		

Part List and Hardware

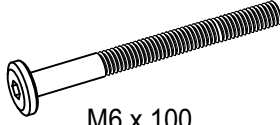
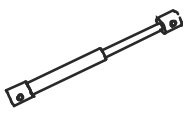
<p>F</p>  <p>(1 PC)</p>	<p>G</p>  <p>(1 PC)</p>	<p>H</p>  <p>(1 PC)</p>	<p>I</p>  <p>(1 PC)</p>
<p>W</p>  <p>(1 PC)</p>	<p>X</p>  <p>(1 PC)</p>	<p>Y</p>  <p>(1 PC)</p>	<p>Z</p>  <p>(1 PC)</p>
<p>1</p>  <p>M6 x 55 mm</p> <p>(6 PCS)</p>	<p>2</p>  <p>M6 x 35 mm</p> <p>(48 PCS)</p>	<p>3</p>  <p>M6 x 25 mm</p> <p>(52PCS)</p>	 <p>Ø6 x 14 mm</p> <p>(78 PCS)</p>
<p>5</p>  <p>(20 PCS)</p>	<p>6</p>  <p>M6 x 20mm</p> <p>(6 PCS)</p>	<p>7</p>  <p>(2 PCS)</p>	 <p>Eru M6</p> <p>(12 PCS)</p>
<p>9</p>  <p>M6</p> <p>(6 PCS)</p>	<p>10</p>  <p>Allenkey 4x 60</p> <p>(2 PCS)</p>	<p>11</p>  <p>Spanner No.10</p> <p>(1 PC)</p>	 <p>(2 PCS)</p>
<p>13</p>  <p>M6 x 100</p> <p>(2 PCS)</p>	<p>14</p>  <p>(2 PCS)</p>		

CARTON CONTENT:

WF301544:



S x1



T x1

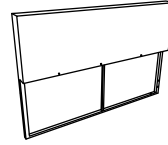

C x2

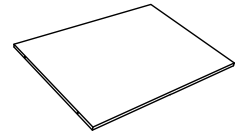

D x2

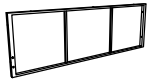

E x2

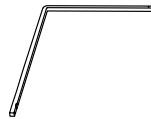

F x1

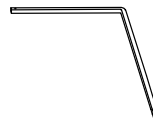

G x1

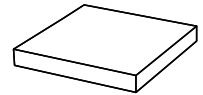

Q x1

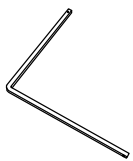

H x1

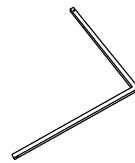

I x1

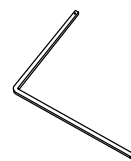

W x1

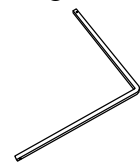

X x1

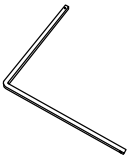

Y x1

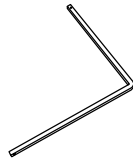

Z x1

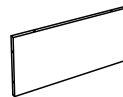

P x4

WF301545:

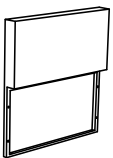

N x2

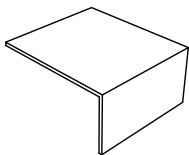

O x1



R x1

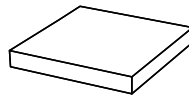

Q x4

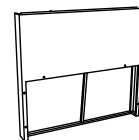

A x1



B x1

WF301546:

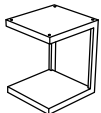

K x1

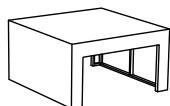

M x1

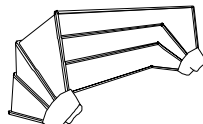

J x1

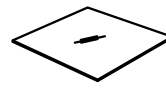

L x1

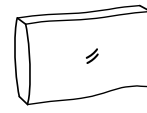

R x4

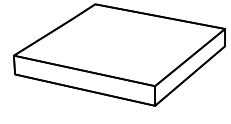

Q x1

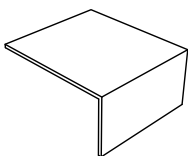

O x1

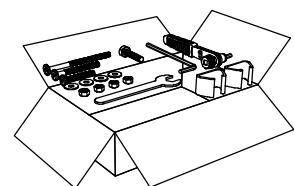

ALL INCLUDED BOX-WF301546

Hardware

Step 1:

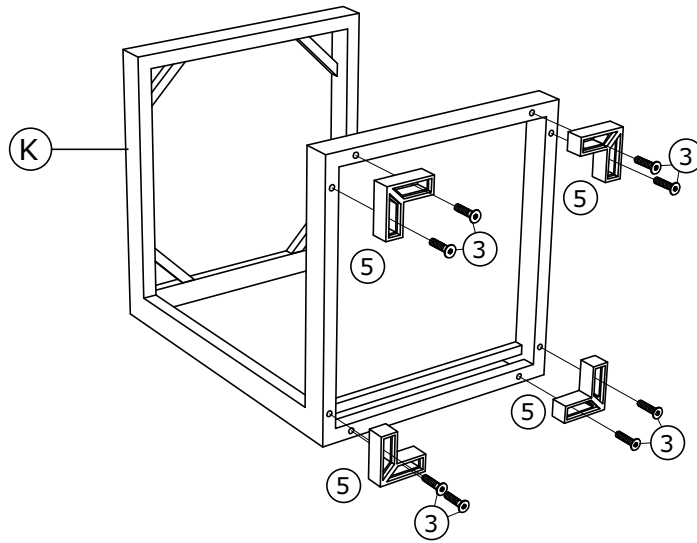

③ *8 ⑤ *4 K*1

Step 2:

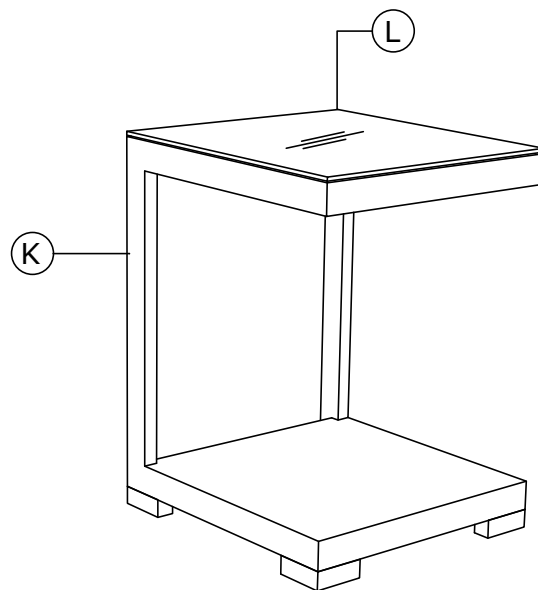

L*1

Step 3:

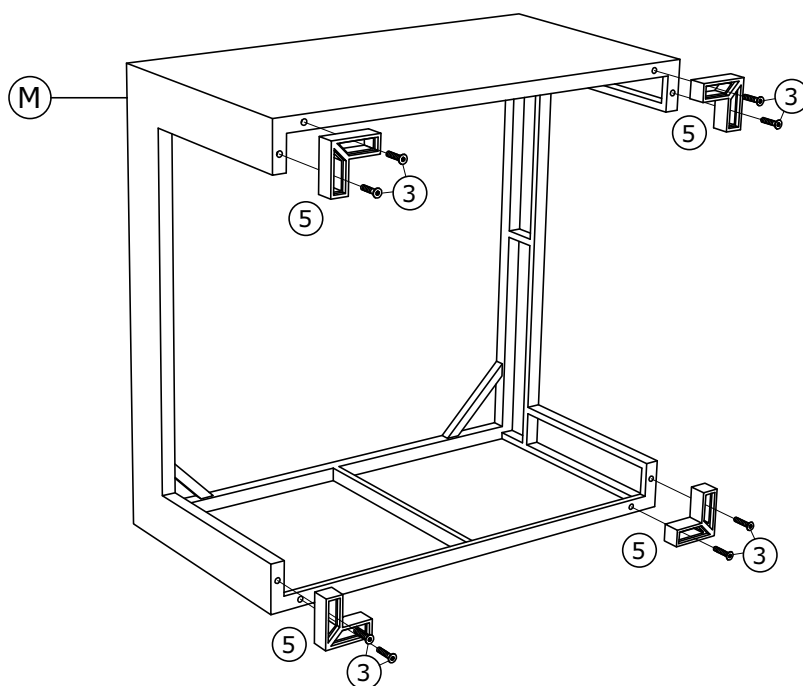
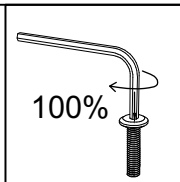

③ *8 ⑤ *4 M *1

Step 4:

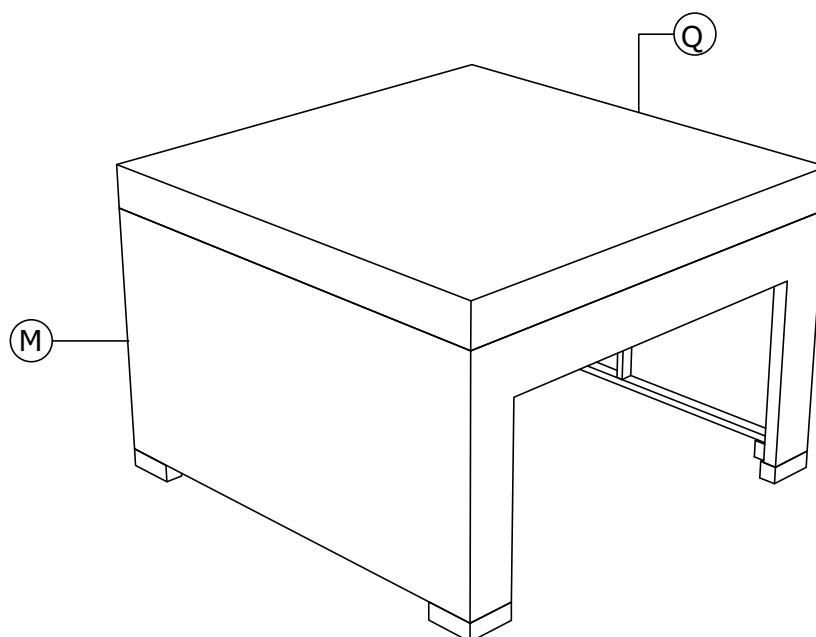

Q *1

Step 5:

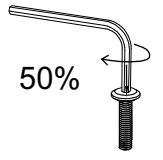
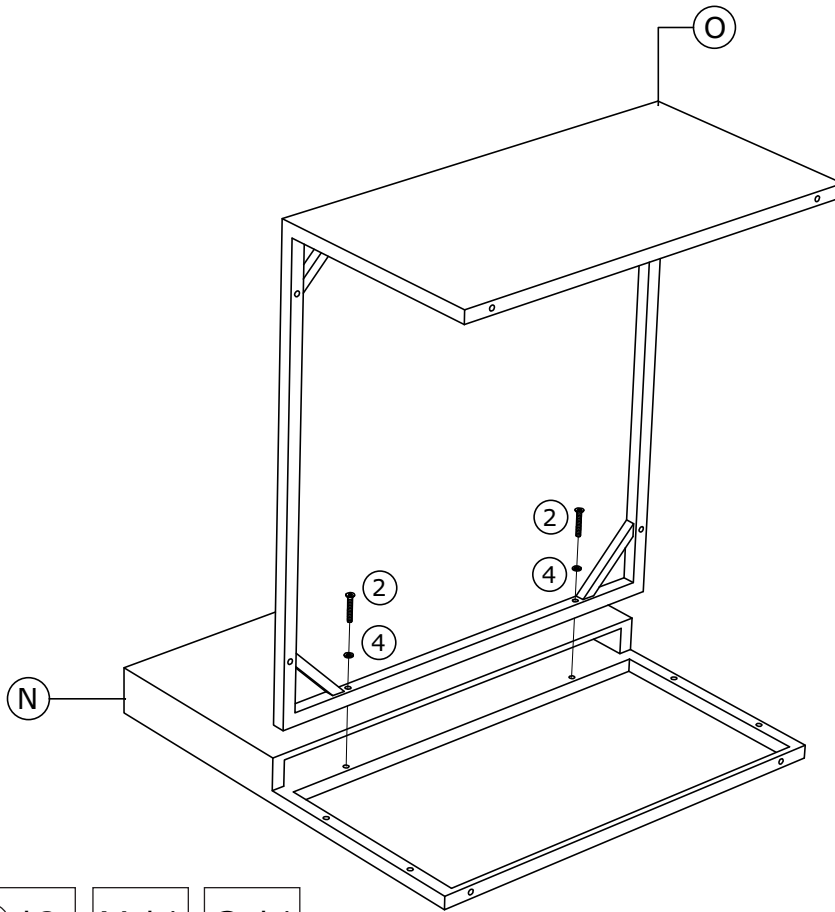

x2

② *2 ④ *2 N *1 O *1

Step 6:

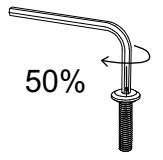
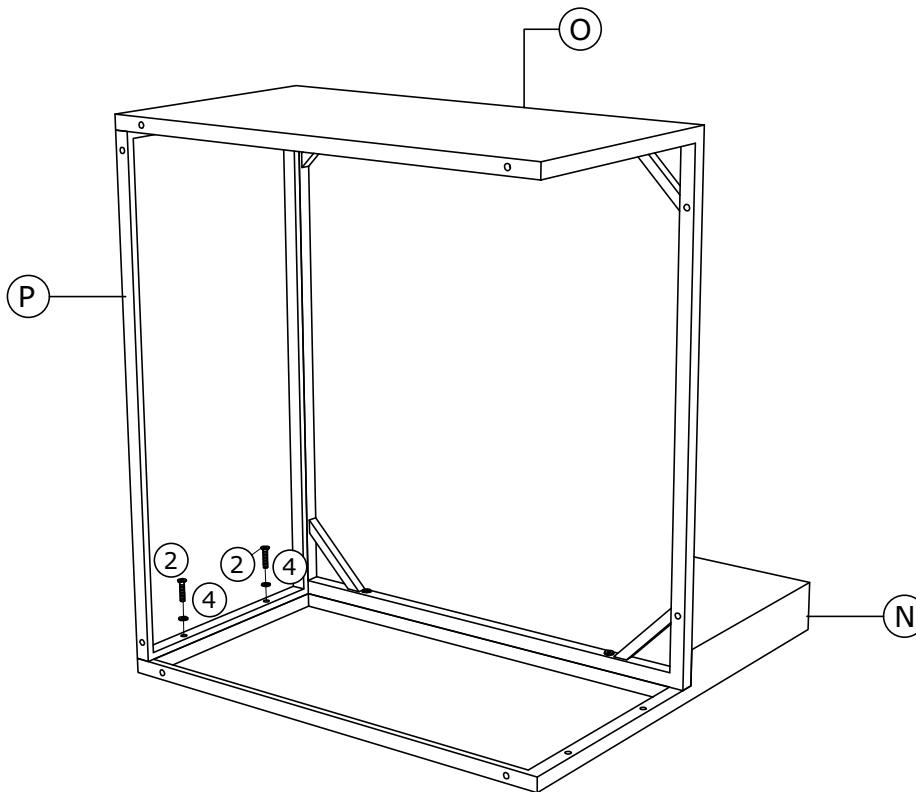

x2

② *2 ④ *2 P *1

Step 7:

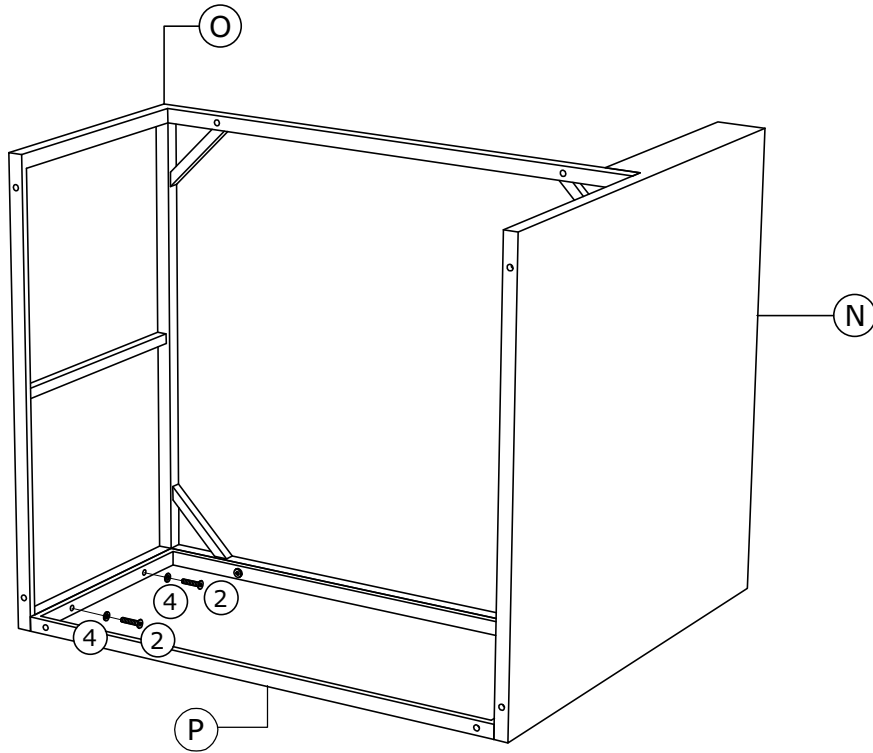
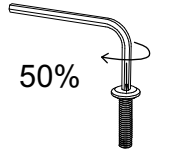

x2

- ② *2
- ④ *2

Step 8:

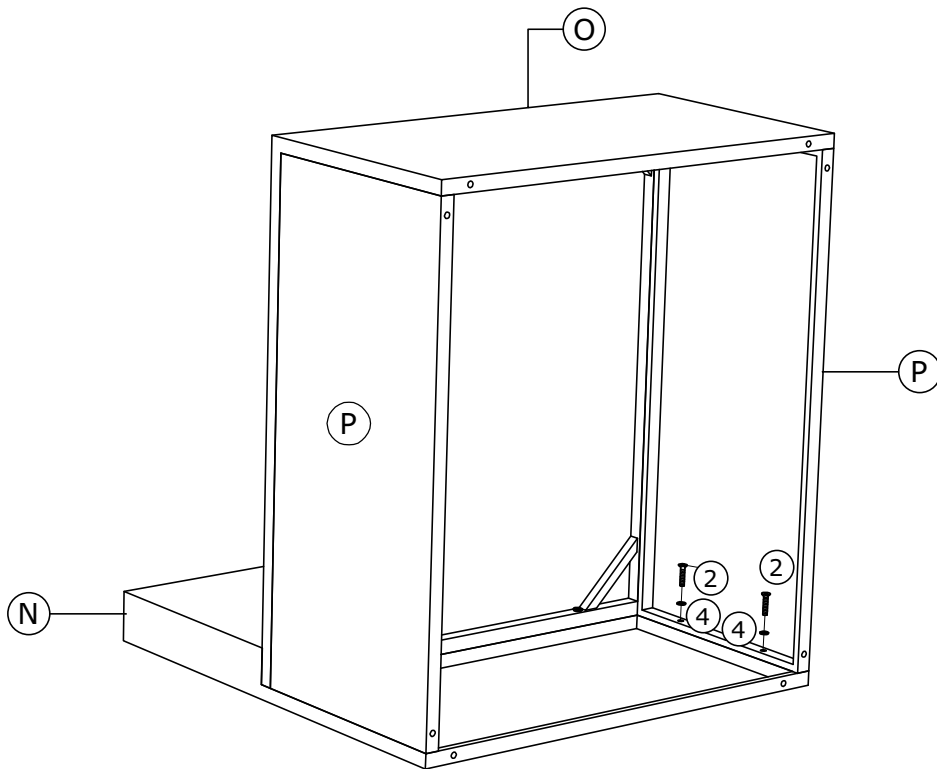
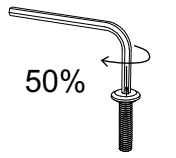

x2

- ② *2
- ④ *2
- P *1

Step 9:

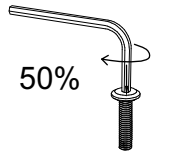
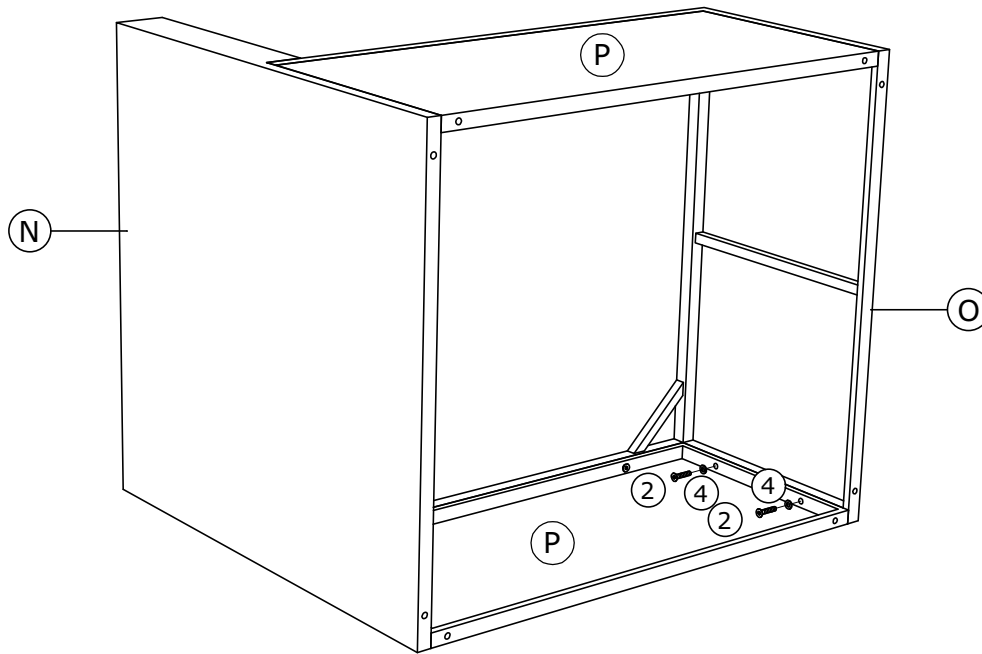

x2

② *2

④ *2

Step 10:

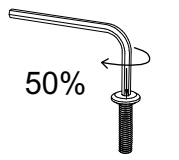
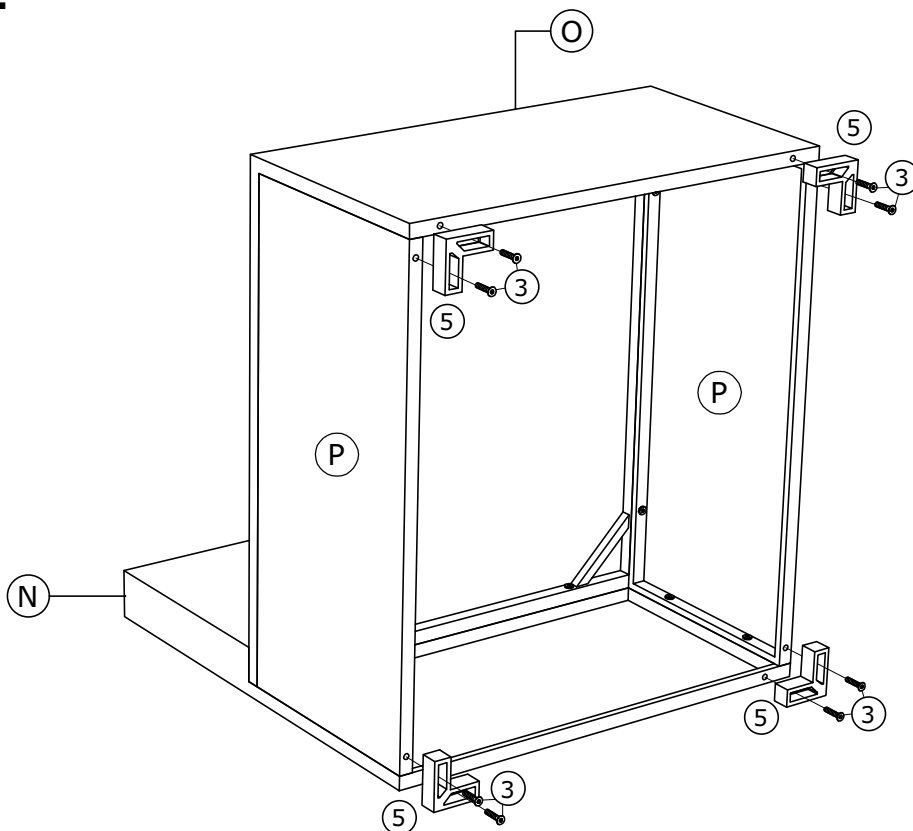

x2

③ *8

⑤ *4

Step 11:

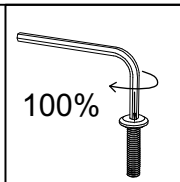

x2

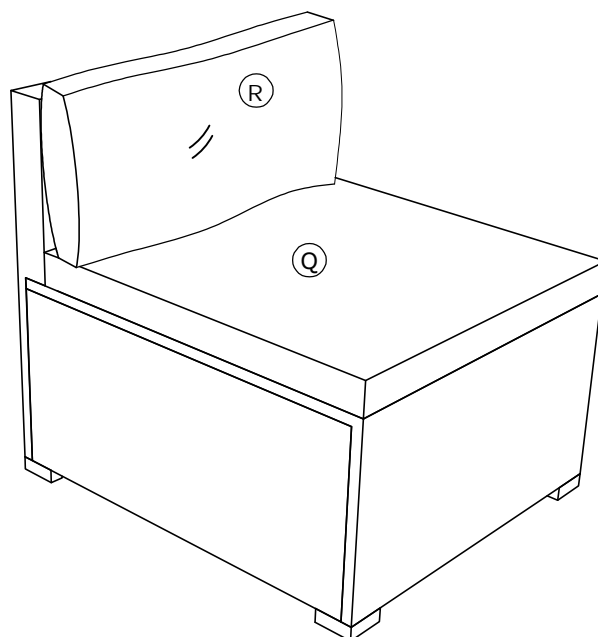

X *1

Y *1

Step 12:

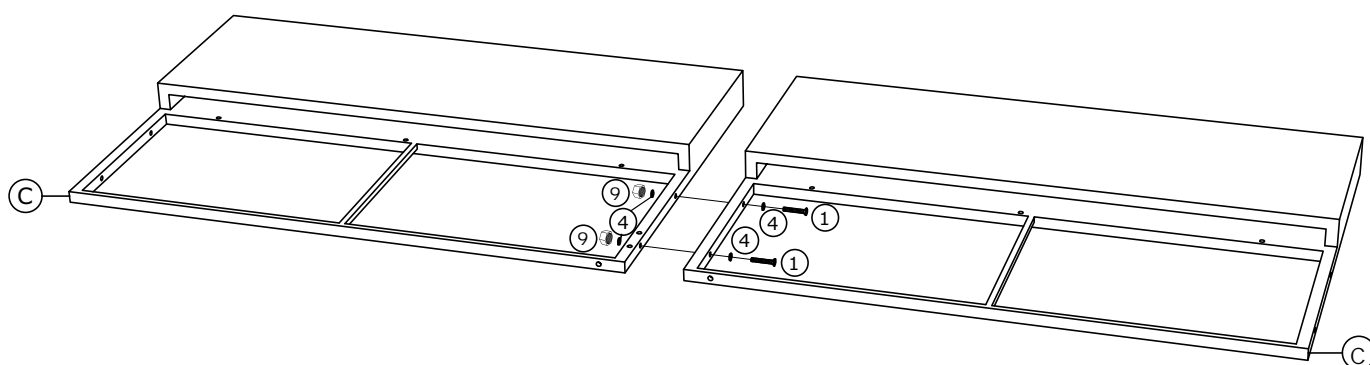
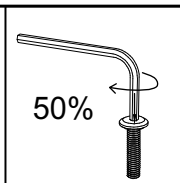

① *2

④ *4

C *2

⑨ *2

Step 13:

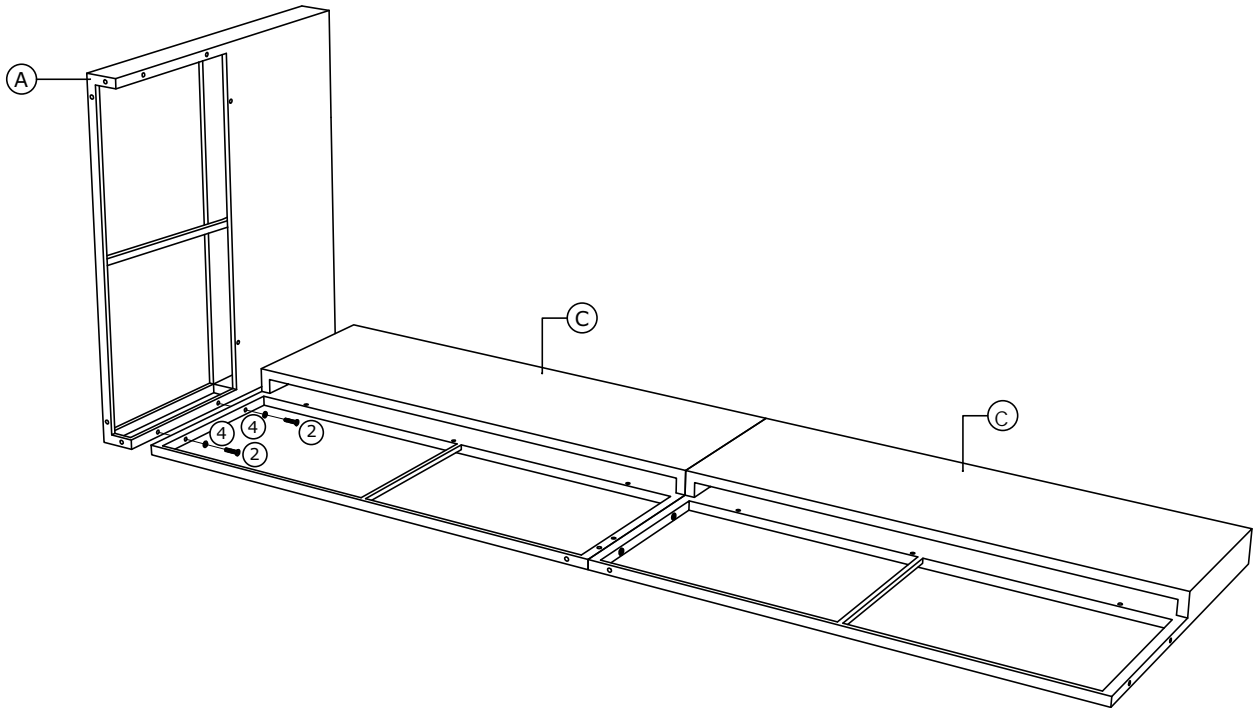

- ② *2
- ④ *2
- A *1

Step 14:

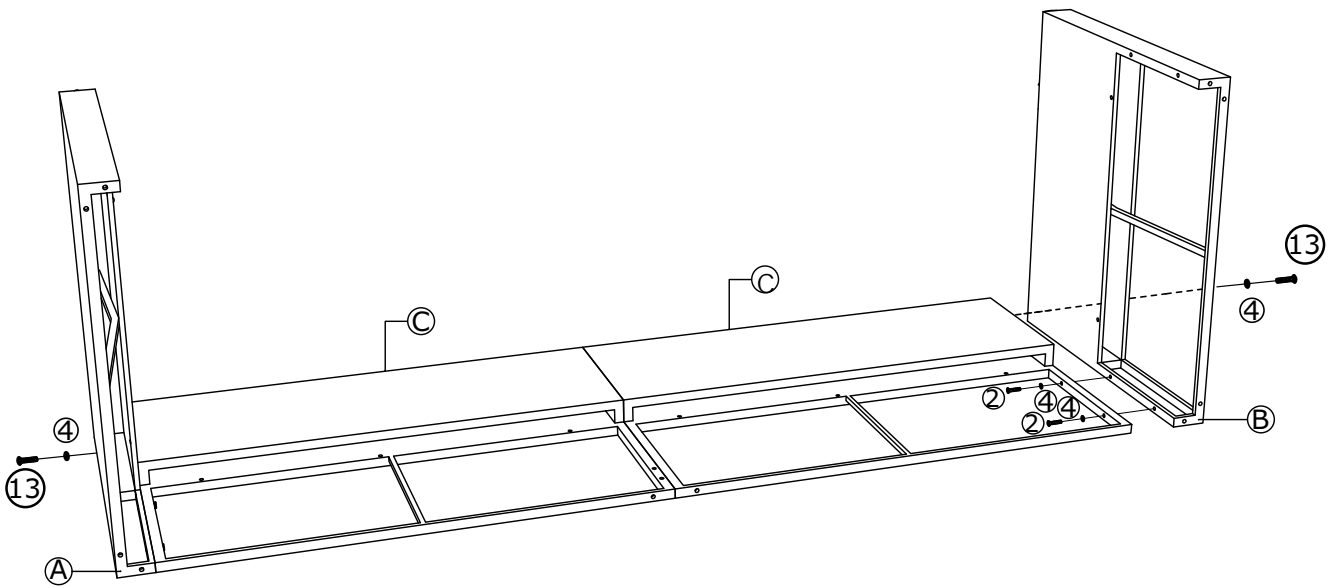

- ② *2
- ④ *4
- 13 *2
- B *1

Step 15:

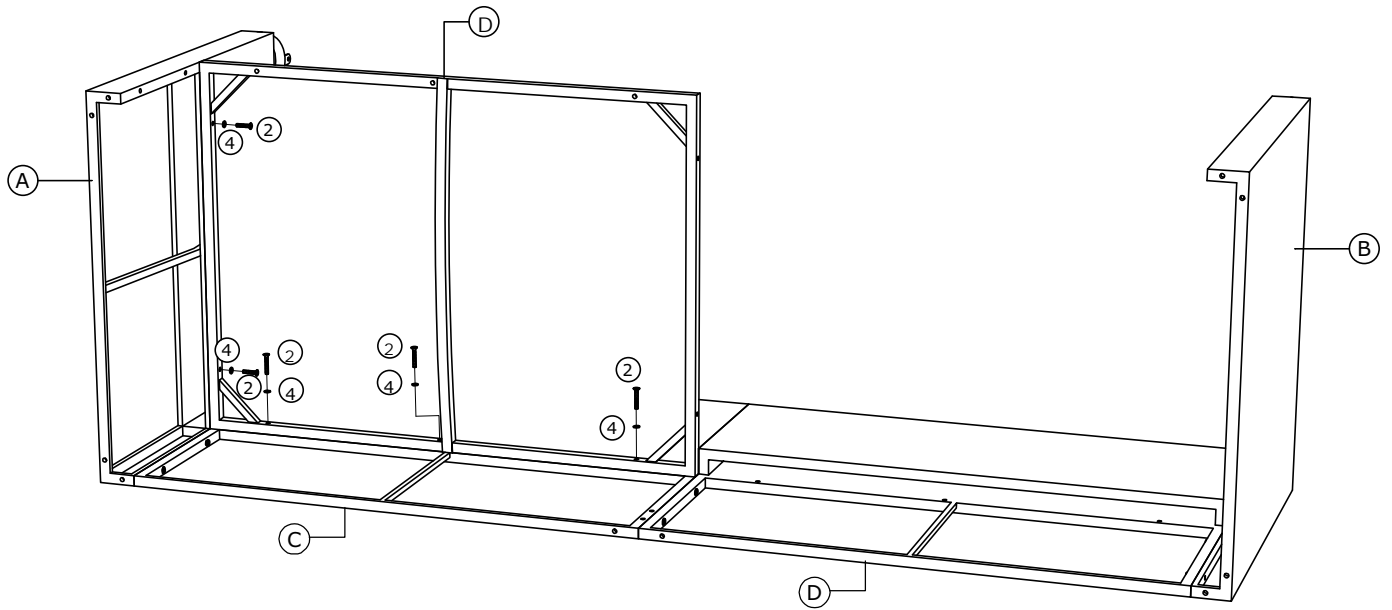
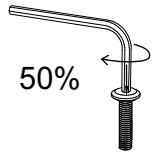

②*5 ④*5 D*1

Step 16:

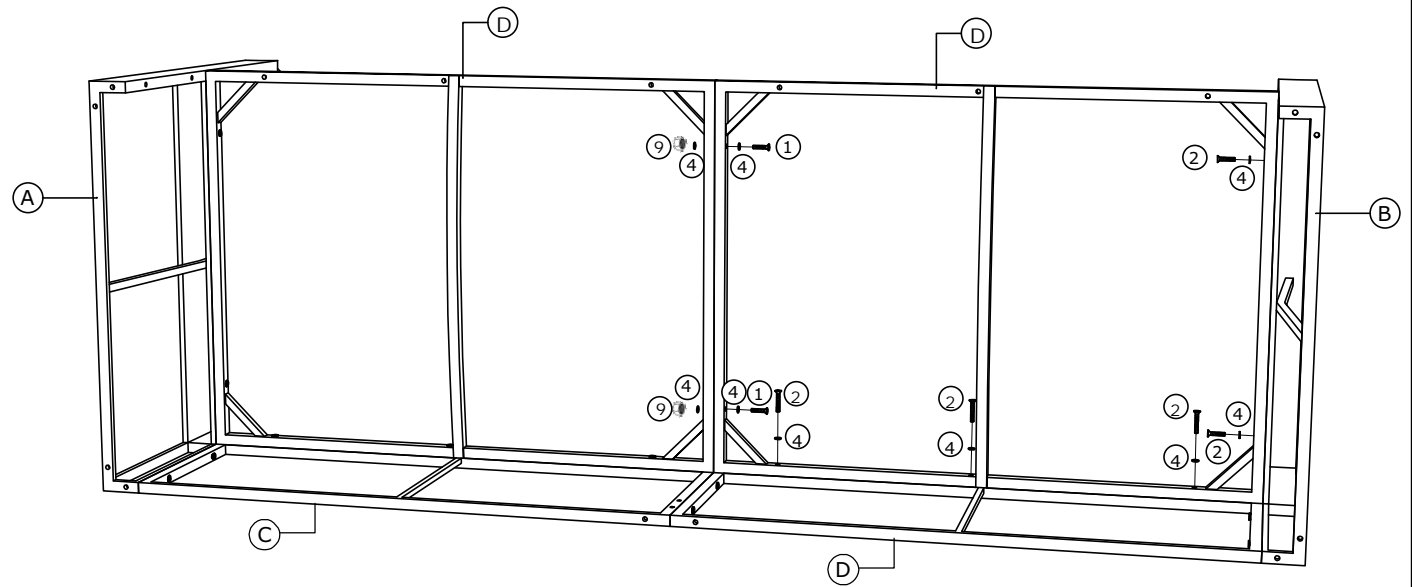
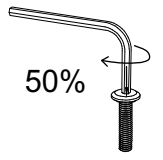

①*2 ④*9 ⑨*2 ②*5 D*1

Step 17:

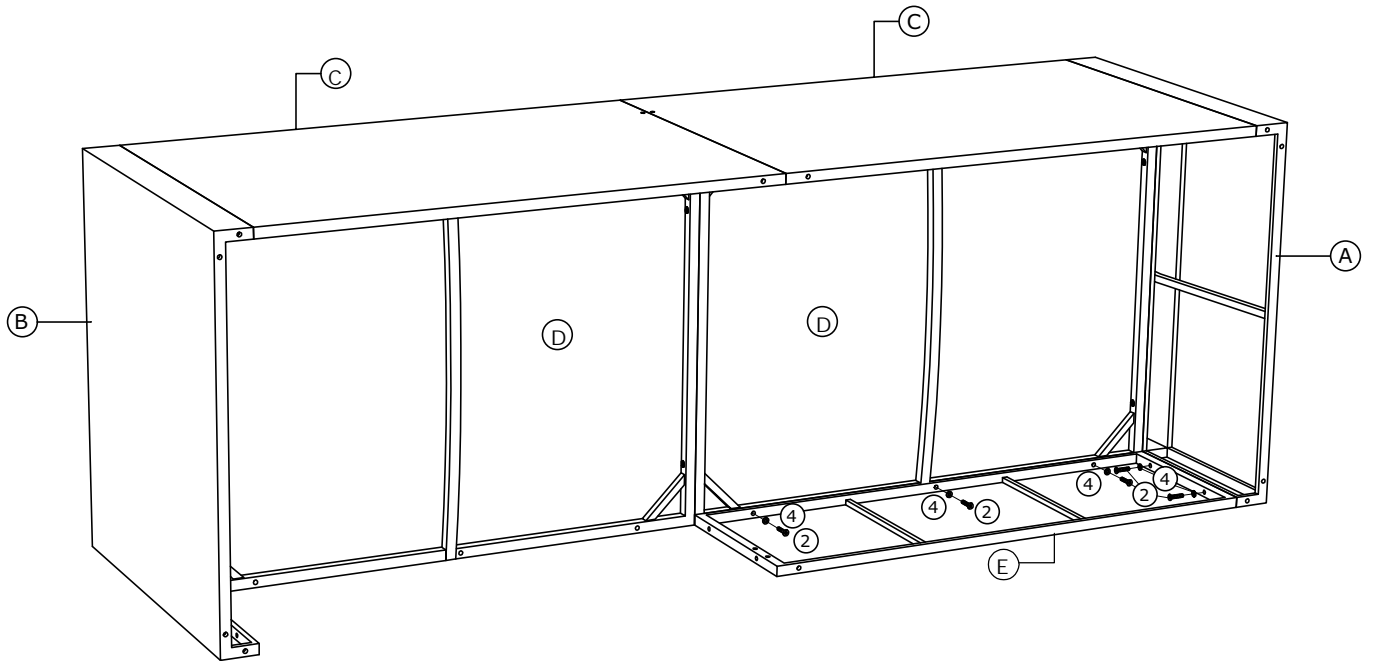
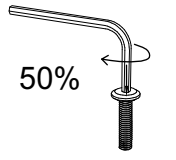

- ② *5
- ④ *5
- E *1

Step 18:

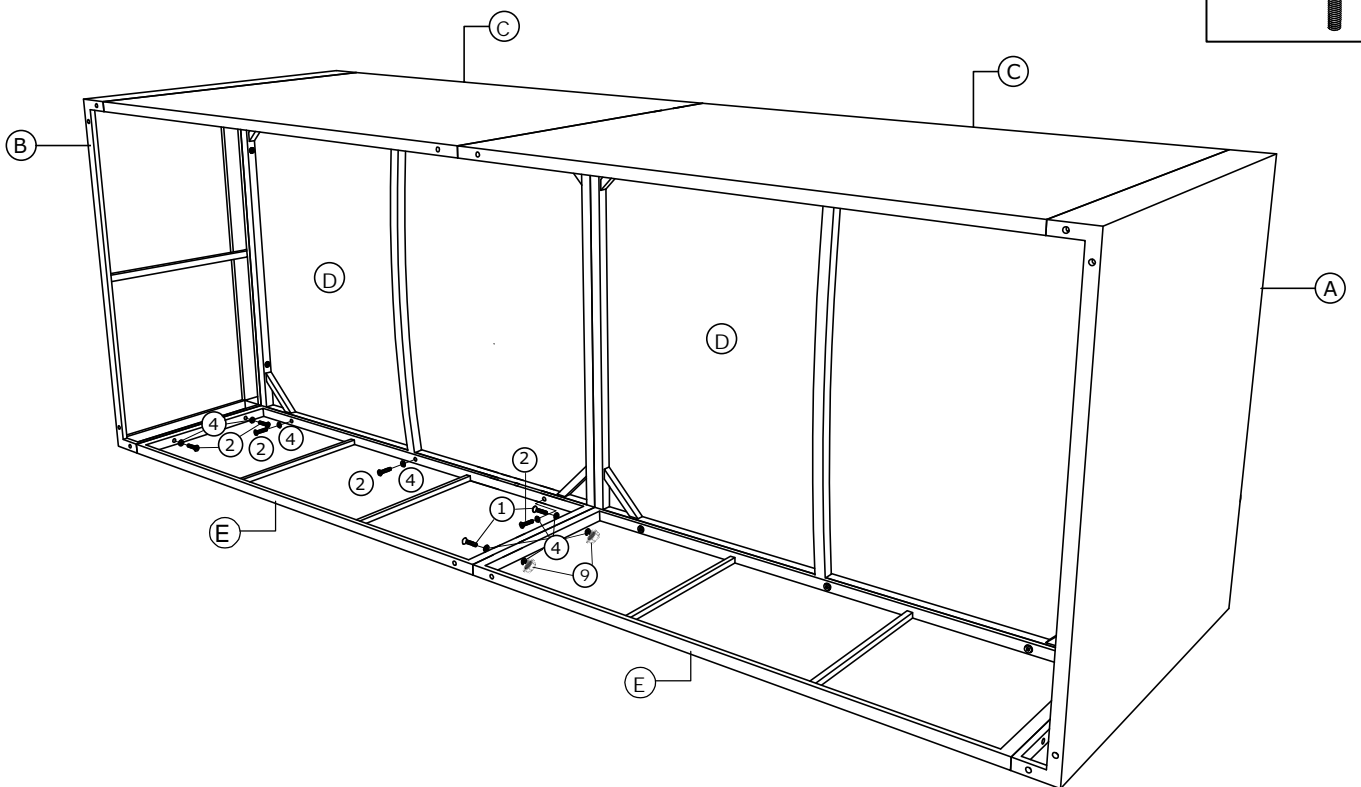
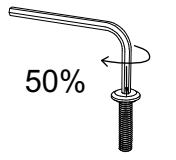

- ① *2
- ② *5
- ④ *9
- E *1
- ⑨ *2

Step 19:

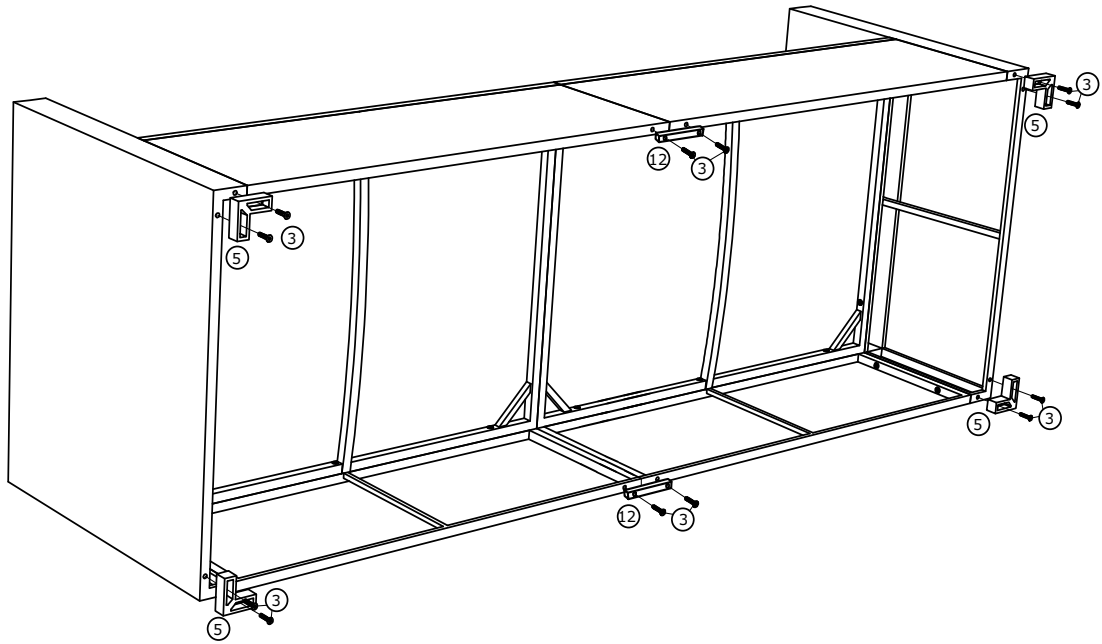
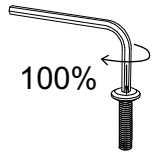

③*12

⑤*4

⑫*2

Step 20:

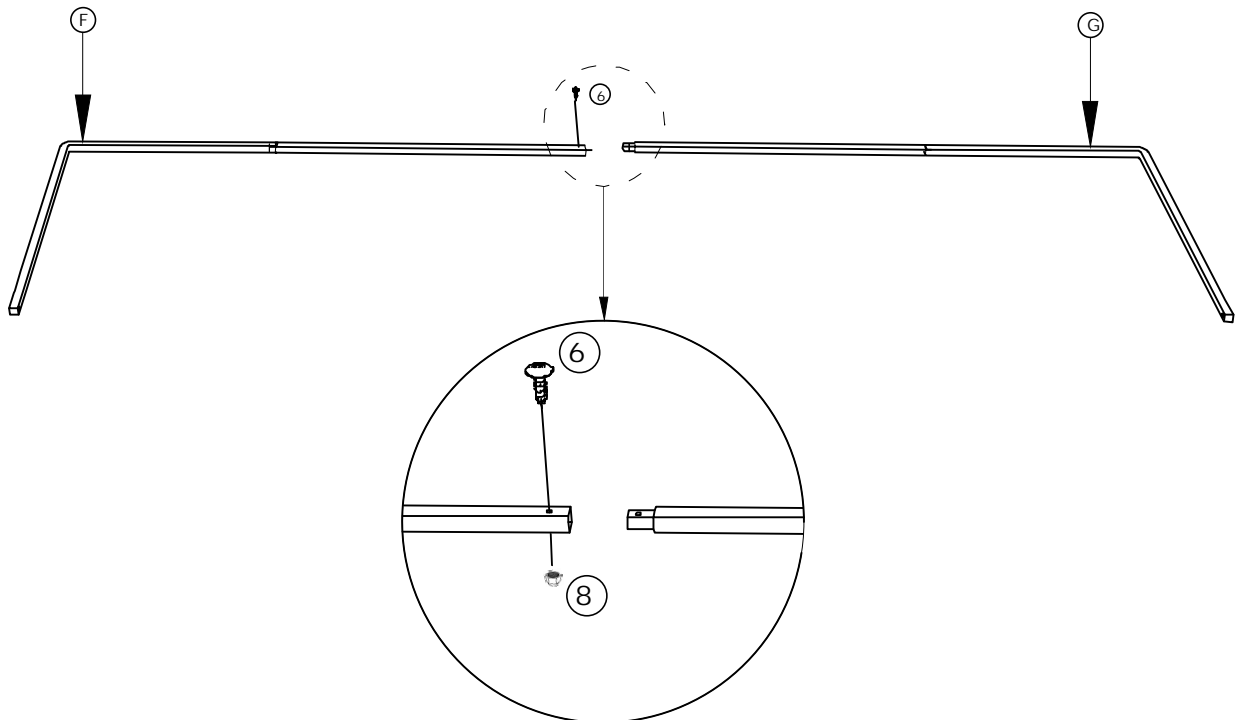
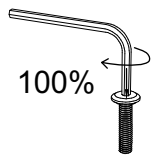

⑧*1

⑥*1

F*1

G*1

Step 21:

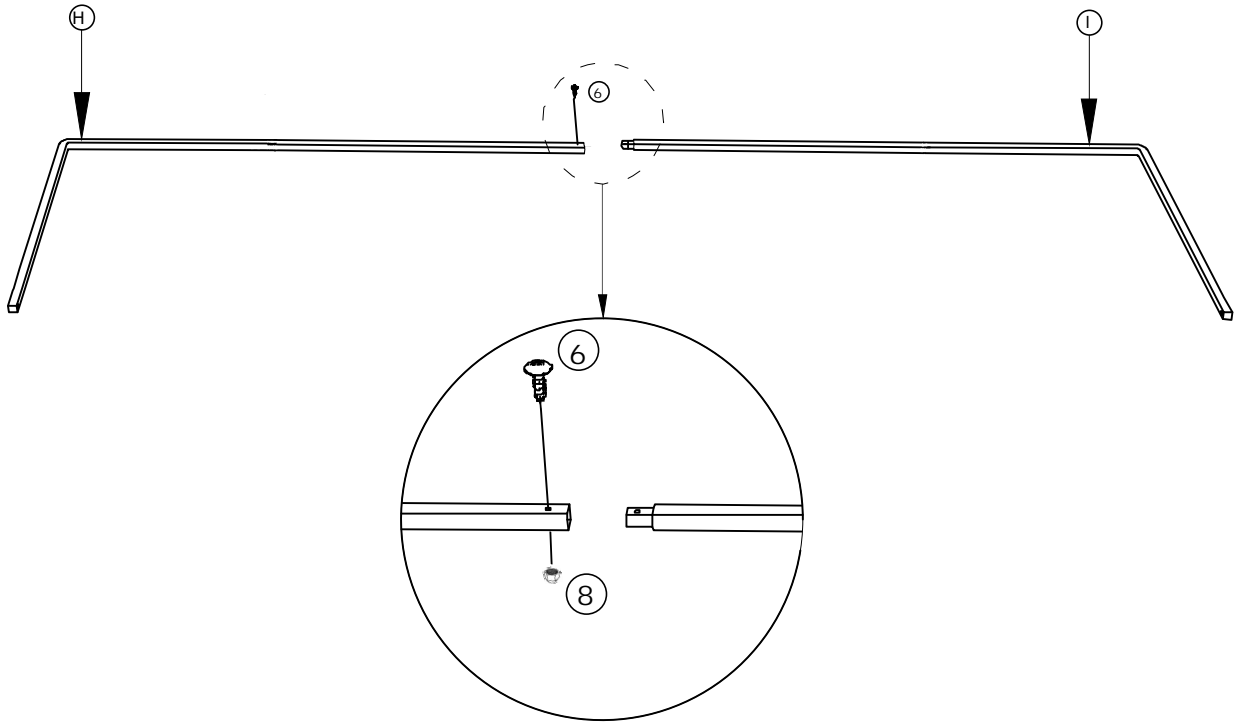
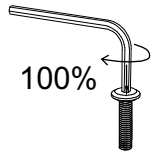

⑥ *1 H*1 I*1 ⑧ *1

Step 22:

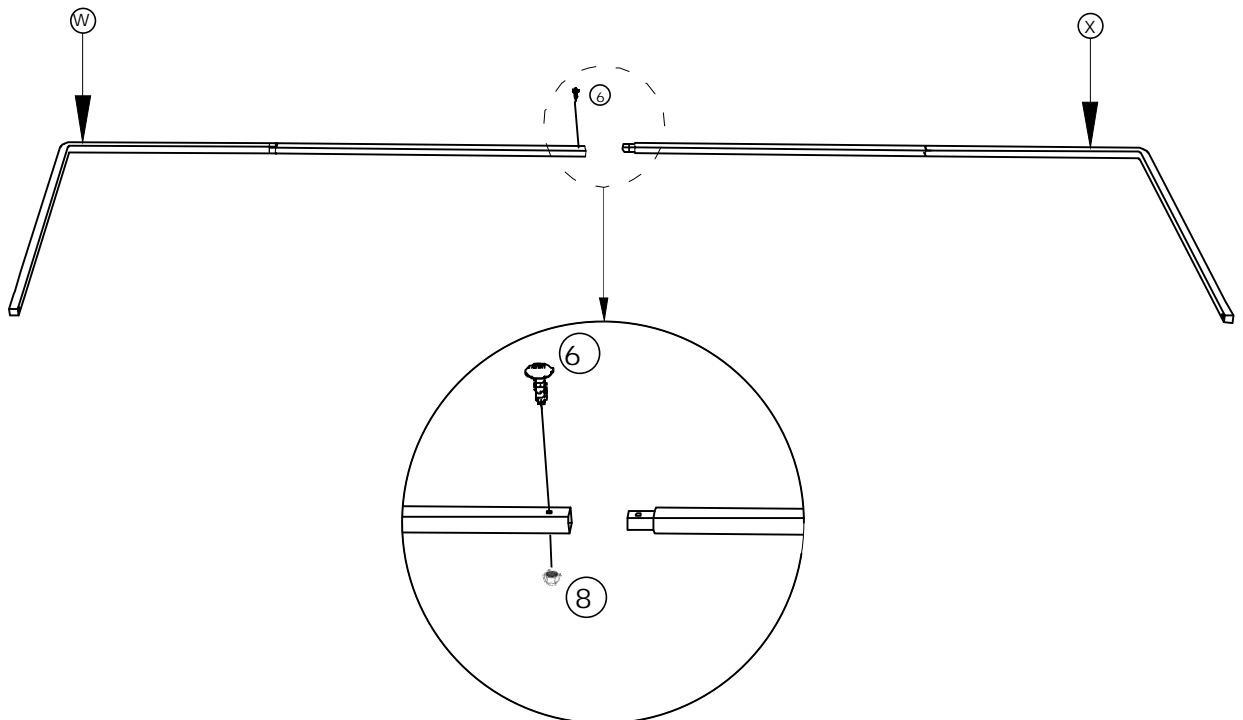
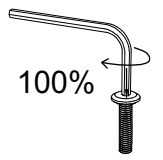

⑥ *1 W*1 X*1 ⑧ *1

Step 23:

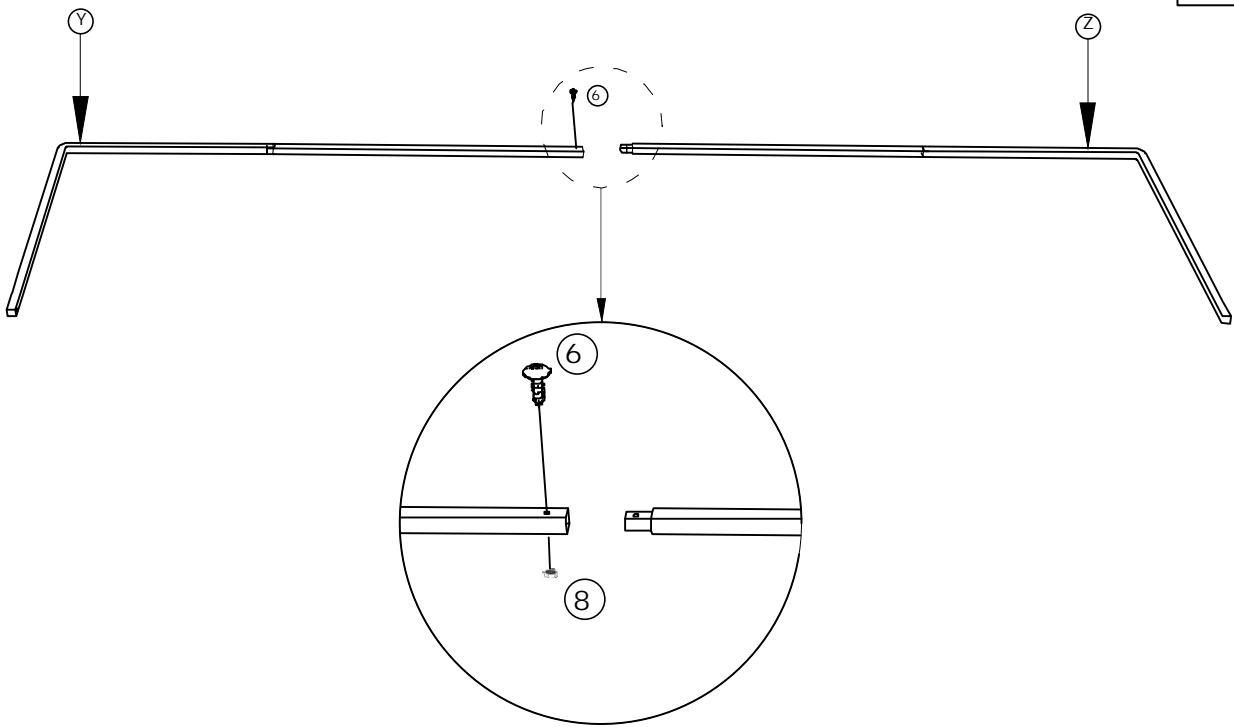

- ⑥ *1
- Y*1
- Z*1
- ⑧ *1

Step 24:

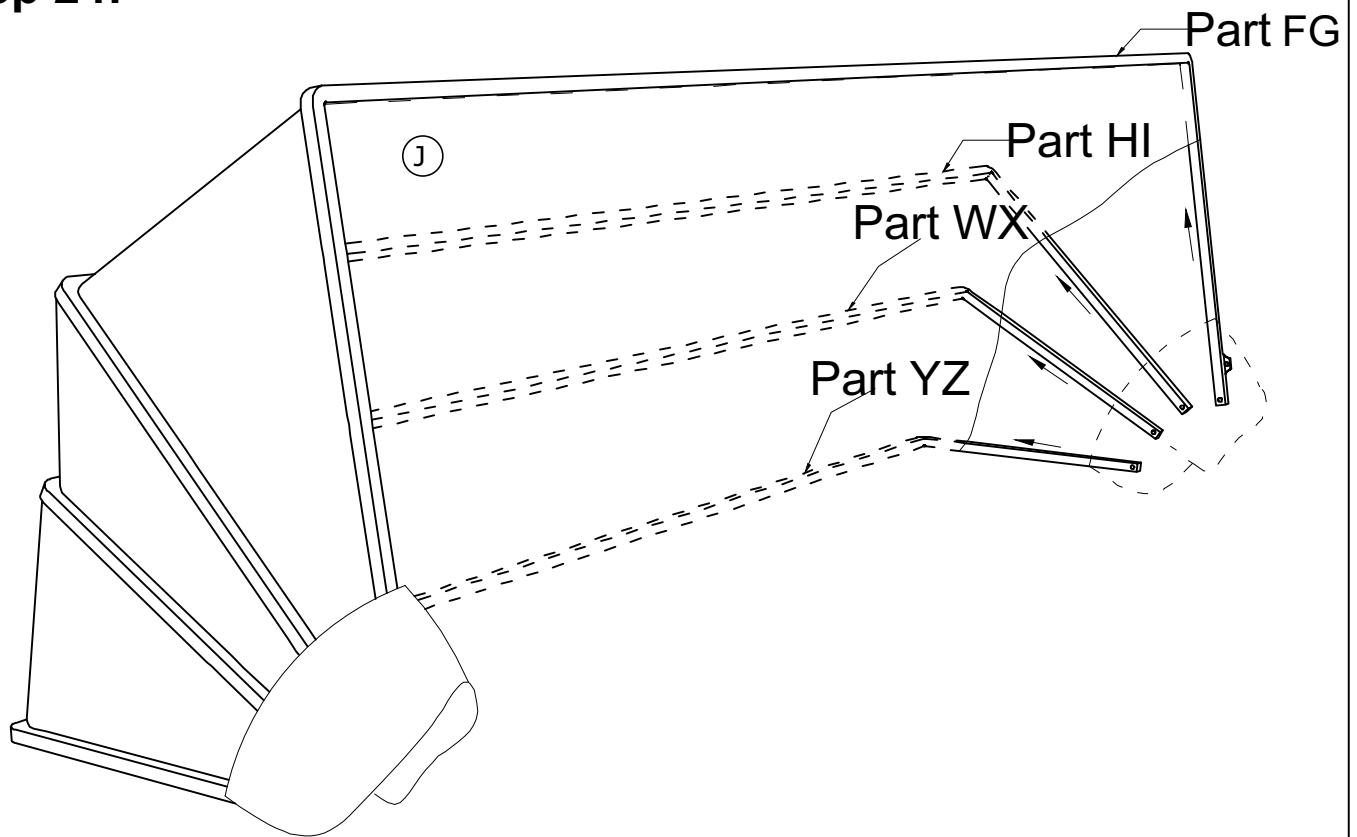

- J *1

Step 25:

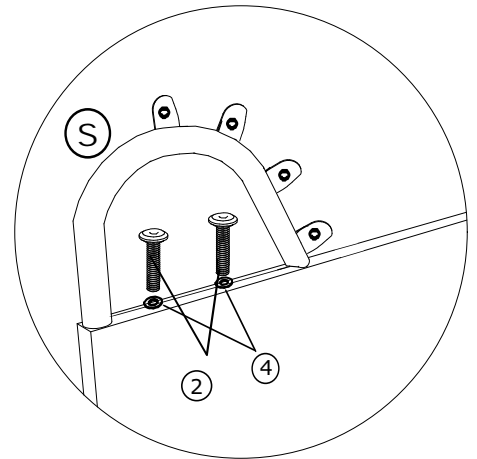
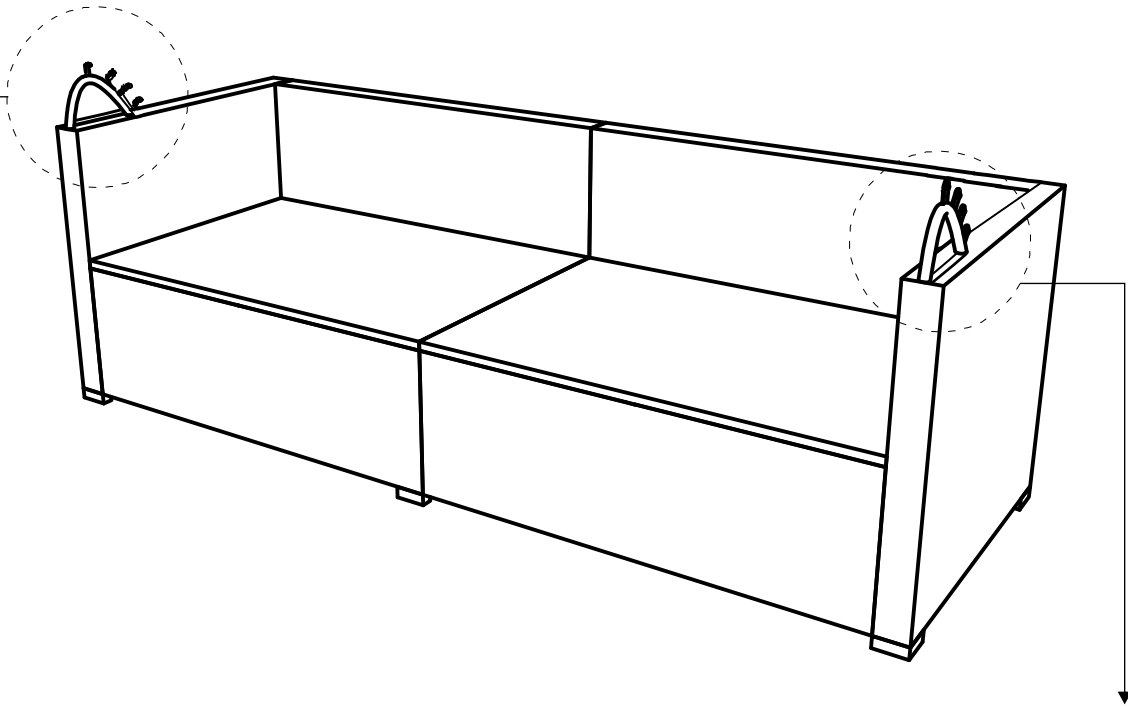
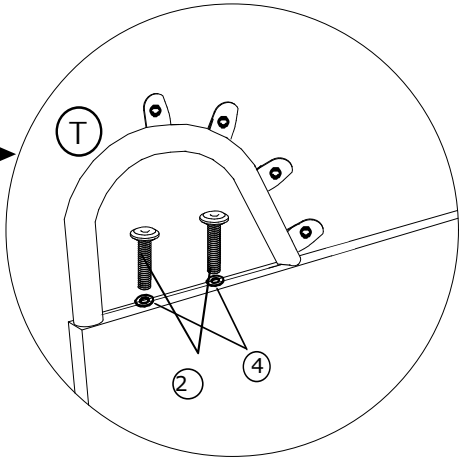

② *4

④ *2

T *1

S *1

Step 26:

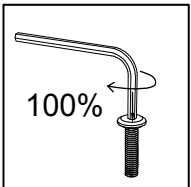
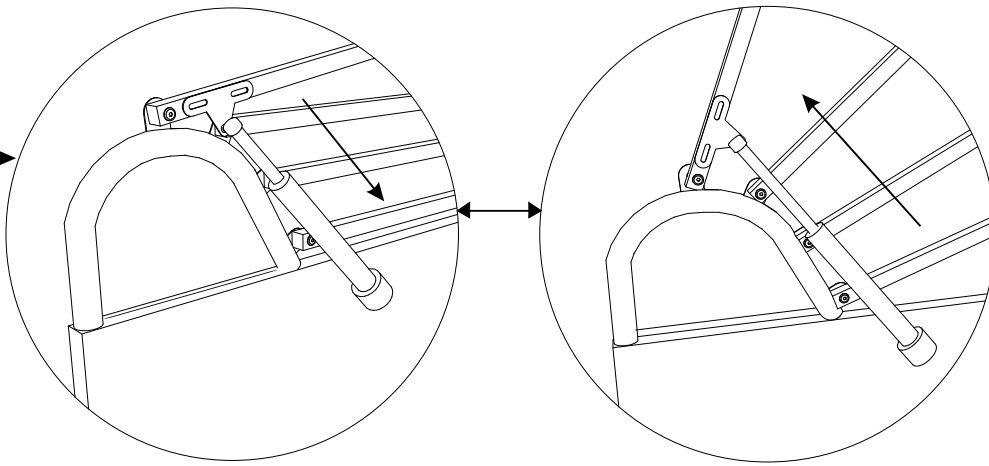

Always Keep The Iron Sheet of Part FG Upward Like "T" not " "

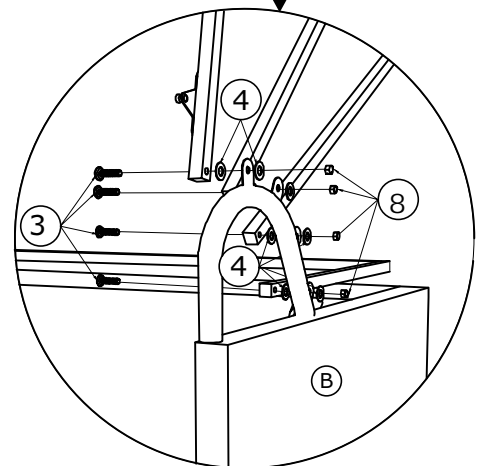
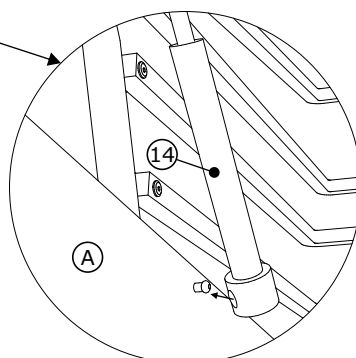
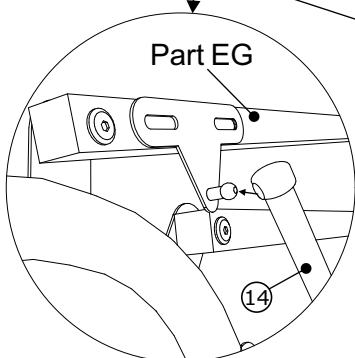
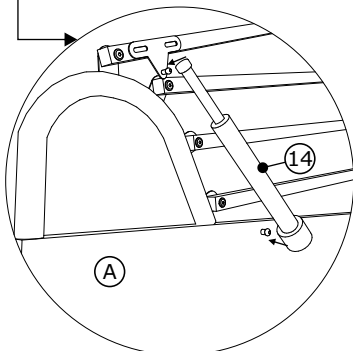
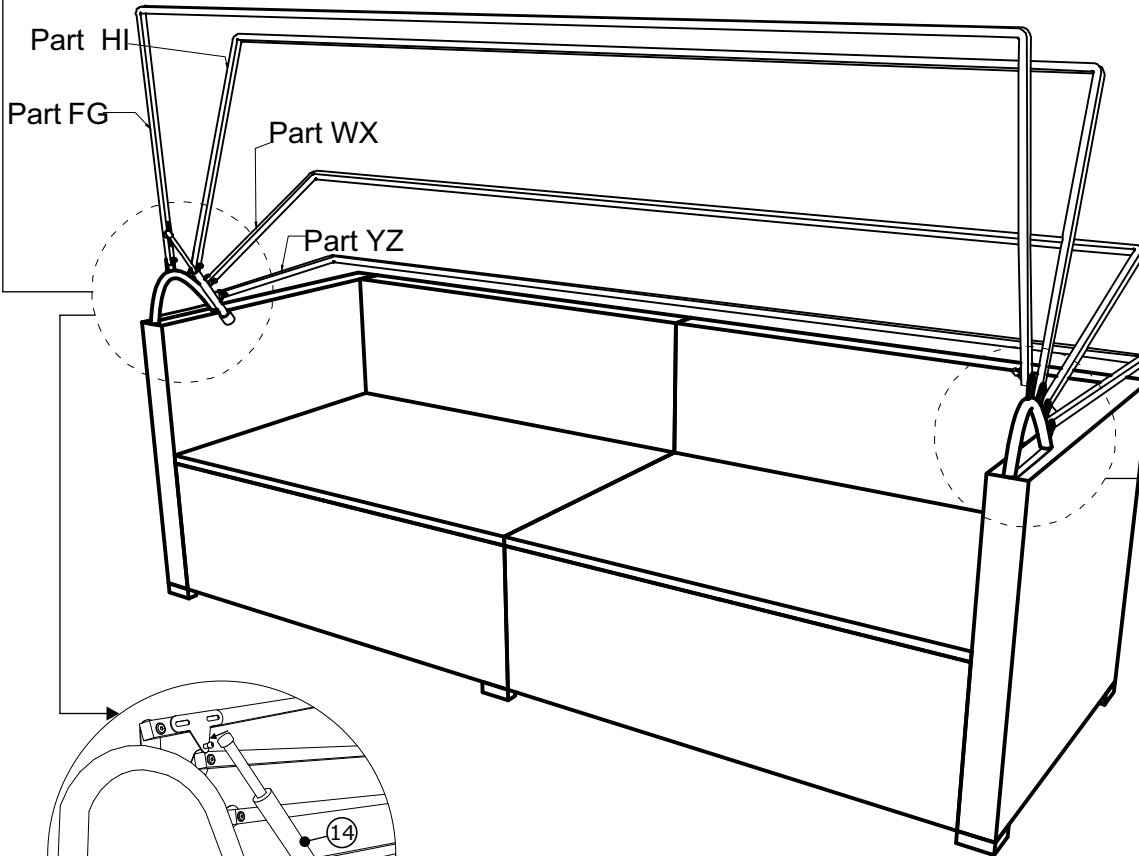

- 4*16
- 8*8
- 14*2
- 3*8

Step 27:

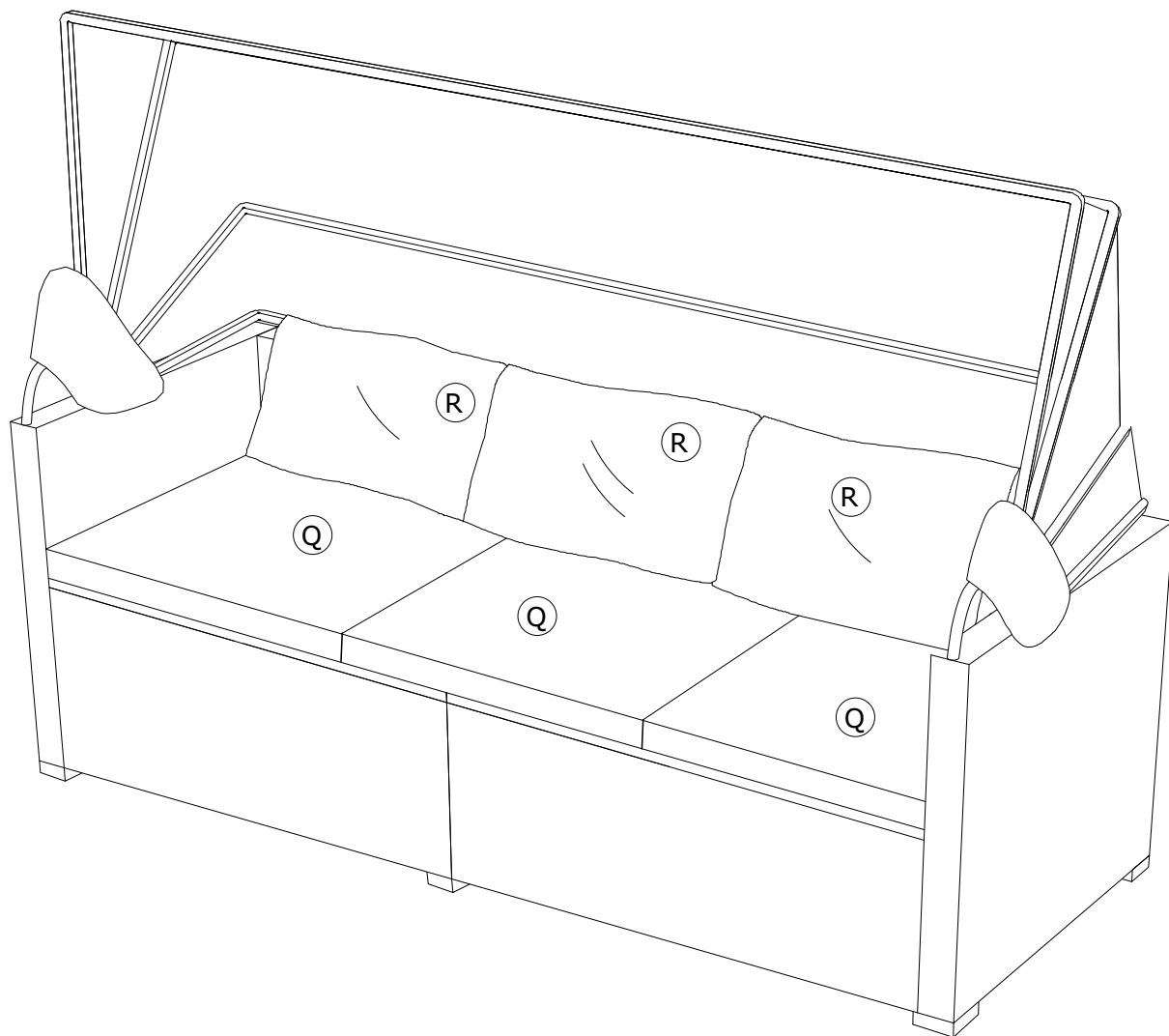

Q *3

R *3