

# ASSEMBLY INSTRUCTION

## RATTAN FURNITURE

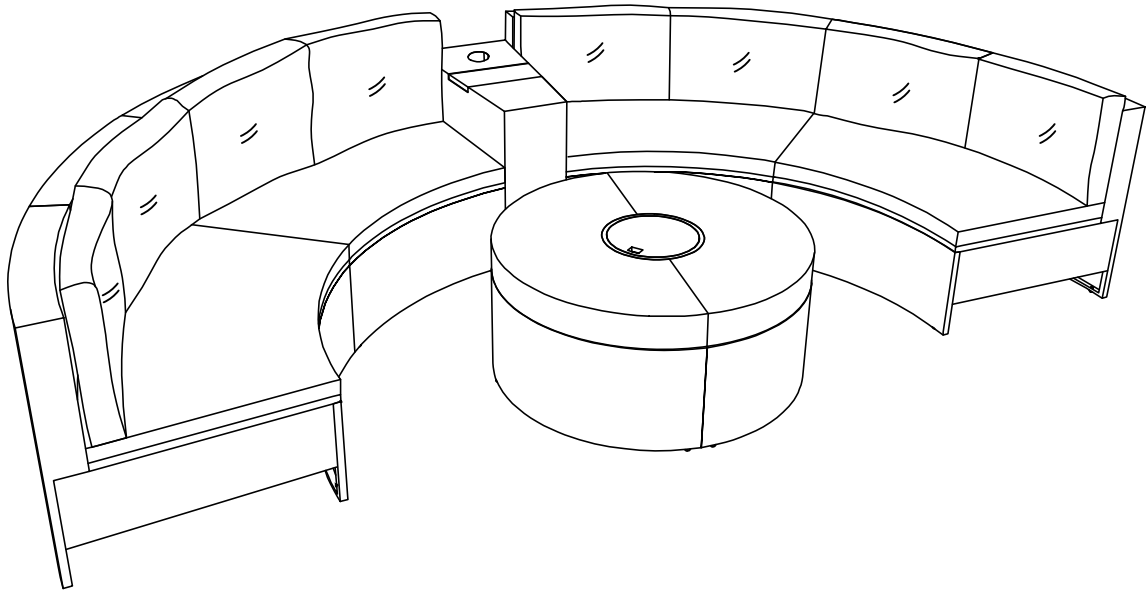

**WF299823; WF299824**

**WF299825; WF299826**

Notice:

1. 50% Tighten before fixing all screws, Allen wrench is recommended instead of an electric drill.
2. Place the item on a flat ground to adjust and make sure it remains stable.
3. Tighten up all screws with tools gradually.
4. If the screws are not aligned with holes during assembly, please loosen all the other screws to 50% and continue the assembly process.
5. If the item is not stable, please loosen all the screws, adjust it on a flat ground and tighten up all screws again.
6. Note : If one or some screws are fully tightened during assembly, chances are the others will not be aligned with holes. In addition, all the holes are designed to be relatively larger to provide more space for the adjustment of the screws.

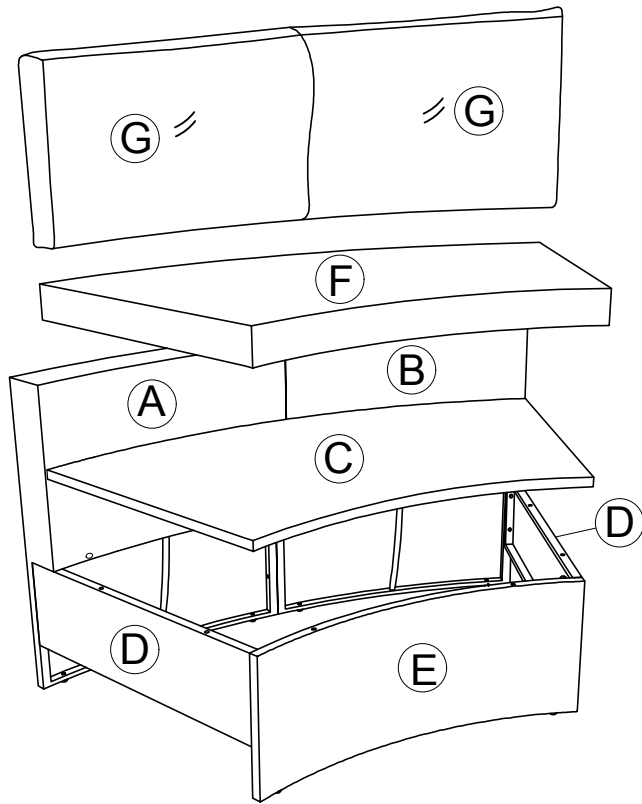

**x4**

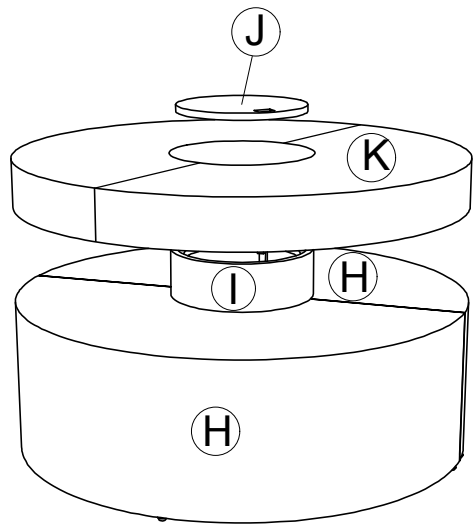



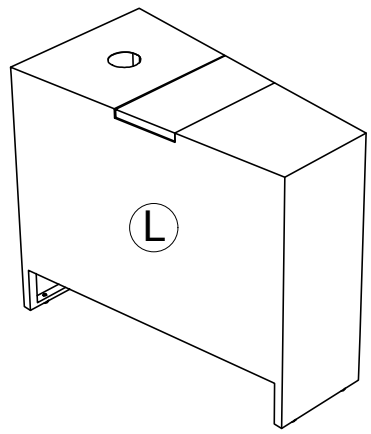



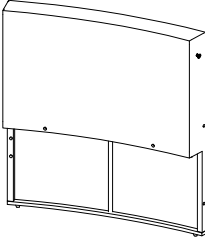
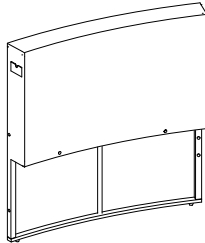
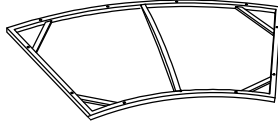
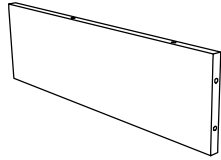
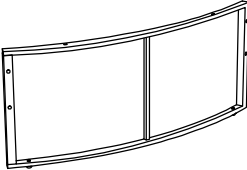
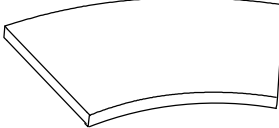
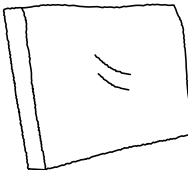
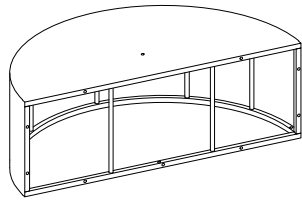
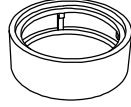
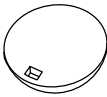
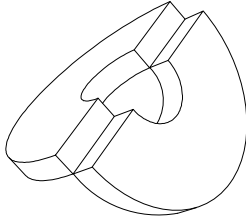
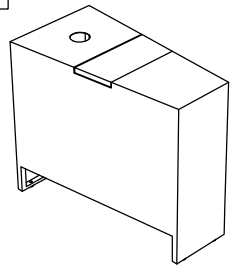

**x1**

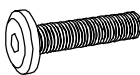
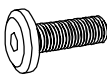

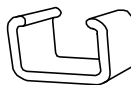
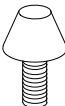
**x1**

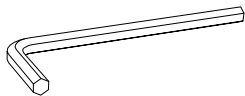
# Part List and Hardware

<p><b>A</b></p>  <p>Right Back Frame(4 pcs)</p>	<p><b>B</b></p>  <p>Left Back Frame(4 pcs)</p>	<p><b>C</b></p>  <p>Seat Bench Frame(4 pcs)</p>	<p><b>D</b></p>  <p>Side Frame(8 pcs)</p>
<p><b>E</b></p>  <p>Front Side Frame(4 pcs)</p>	<p><b>F</b></p>  <p>Seat Cushion (4 pcs)</p>	<p><b>G</b></p>  <p>Back Cushion (8 pcs)</p>	<p><b>H</b></p>  <p>Stool Frame (2 pcs)</p>
<p><b>I</b></p>  <p>Tray(1 pc)</p>	<p><b>J</b></p>  <p>Top Tray(1 pc)</p>	<p><b>K</b></p>  <p>Seat Stool Cushion (1 pc)</p>	<p><b>L</b></p>  <p>Side Table (1 pc)</p>
<p><b>1</b></p>  <p>Bolt M6x50 (17 pcs)</p>	<p><b>2</b></p>  <p>Bolt M6x40 (16 pcs)</p>	<p><b>3</b></p>  <p>Bolt M6x30 (58 pcs)</p>	<p><b>4</b></p>  <p>Washer M6 (108 pcs)</p>
<p><b>5</b></p>  <p>Connector (8 pcs)</p>	<p><b>6</b></p>  <p>Adjustable Feet (12 pcs)</p>	<p><b>7</b></p>  <p>Ecu (17 pcs)</p>	<p><b>8</b></p>  <p>Allen Key(2 pcs)</p> <p><b>9</b></p>  <p>Key (1 pc)</p>
			<p>03-12</p>

WF299823AAE

CARTON CONTENT:

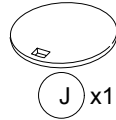
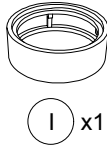
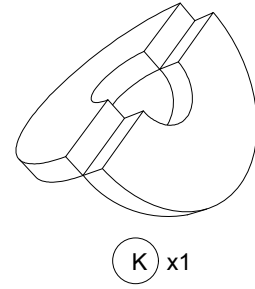
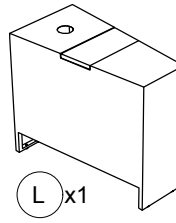
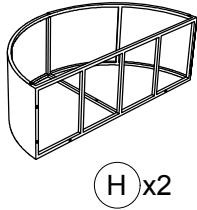

WF299824AAE

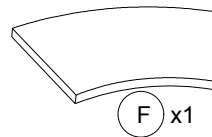
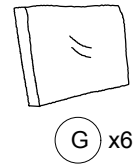
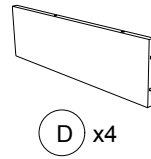
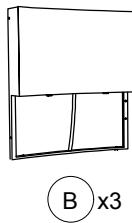
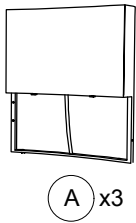

WF299825AAE

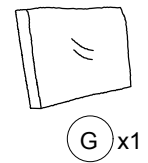
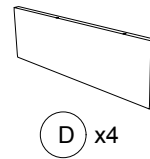
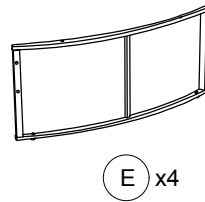
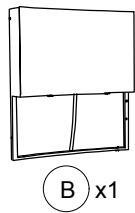
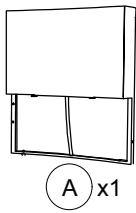

WF299826AAE

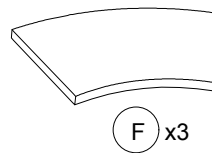
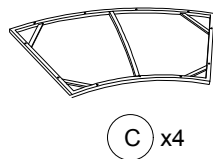

# STEP 1

A x1

B x1

① x2

④ x4

⑦ x2

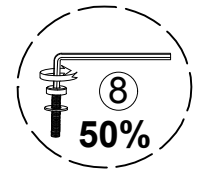
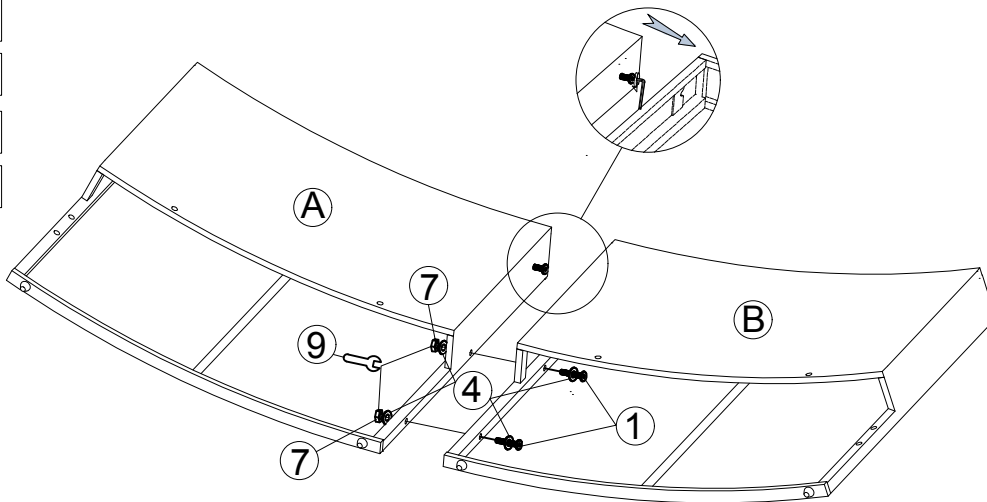

X4

Connect Right Back Sofa (A) & Left Back Sofa (B) with Bolt (1), washer (4), Ecrus (7).

# STEP 2

C x1

② x4

④ x4

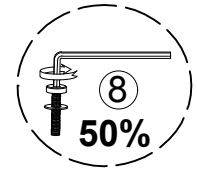
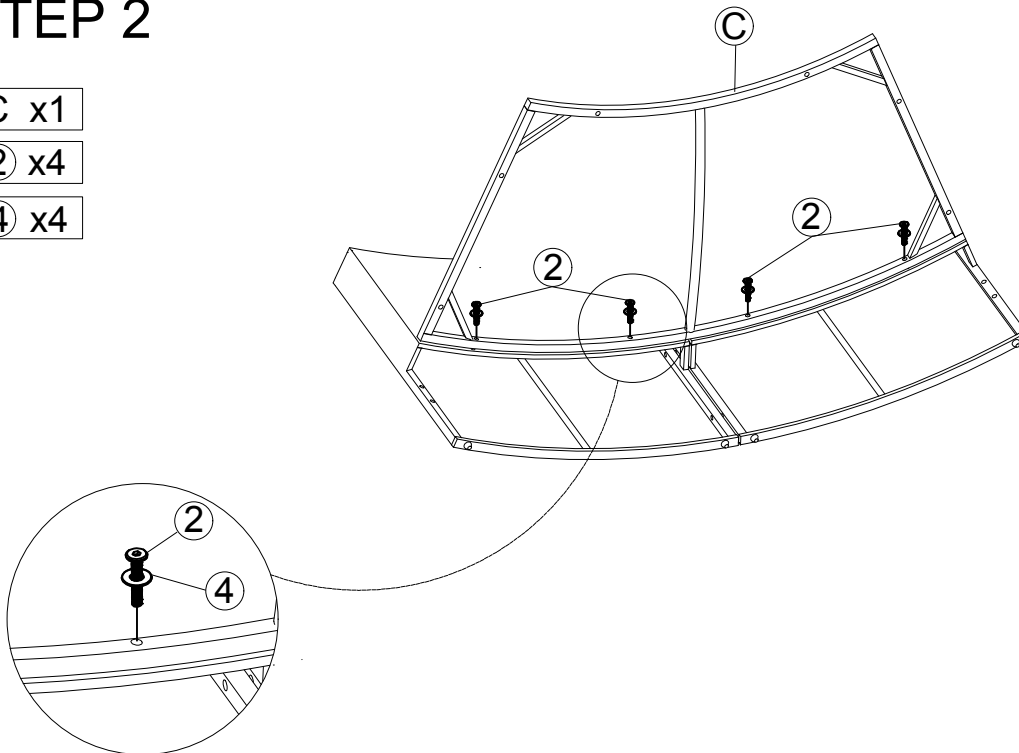

X4

Connect the Part from Step 1 & Seat Bench Frame (C) with Bolt (2), washer (4).

# STEP 3

E x1

③ x2

④ x2

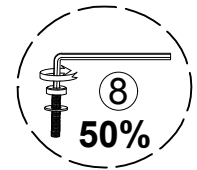
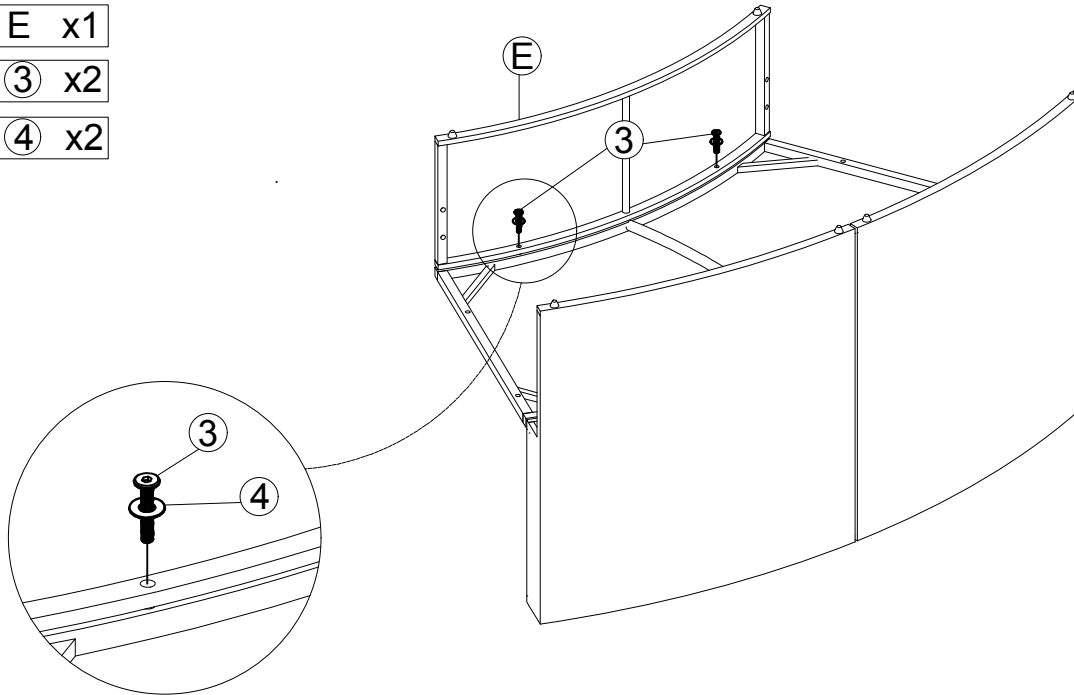

X4

Connect the Part from Step 2 & Front Side Frame (E) with Bolt (3), washer (4).

# STEP 4

D x2

③ x12

④ x12

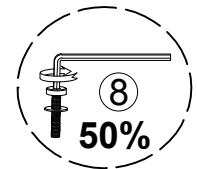
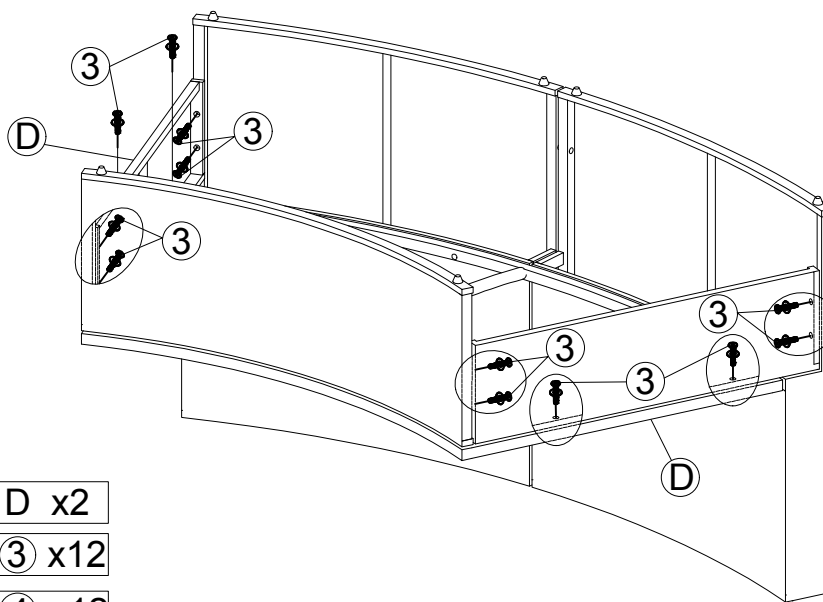

X4

Connect the Part from Step 3 & Side Frame (D) with Bolt (3), washer (4).

## STEP 5

F x1

G x2

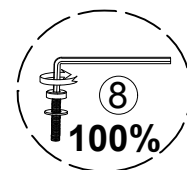

X4

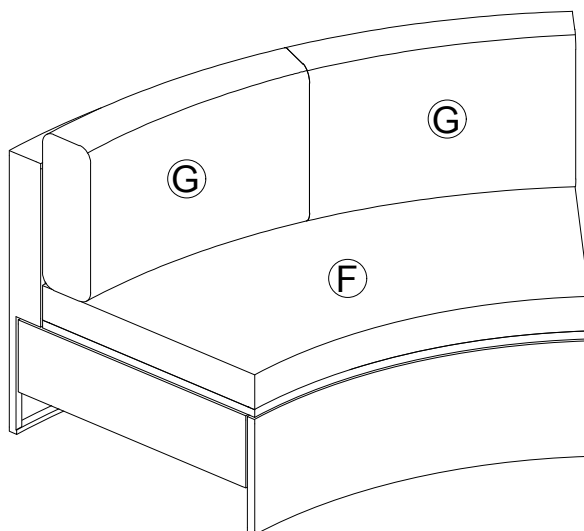

Put the Seat Cushion (F) & Back Cushion (G) to Finish Bench.

## STEP 6

H x2

① x9

④ x18

⑦ x9

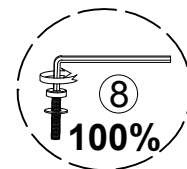

X1

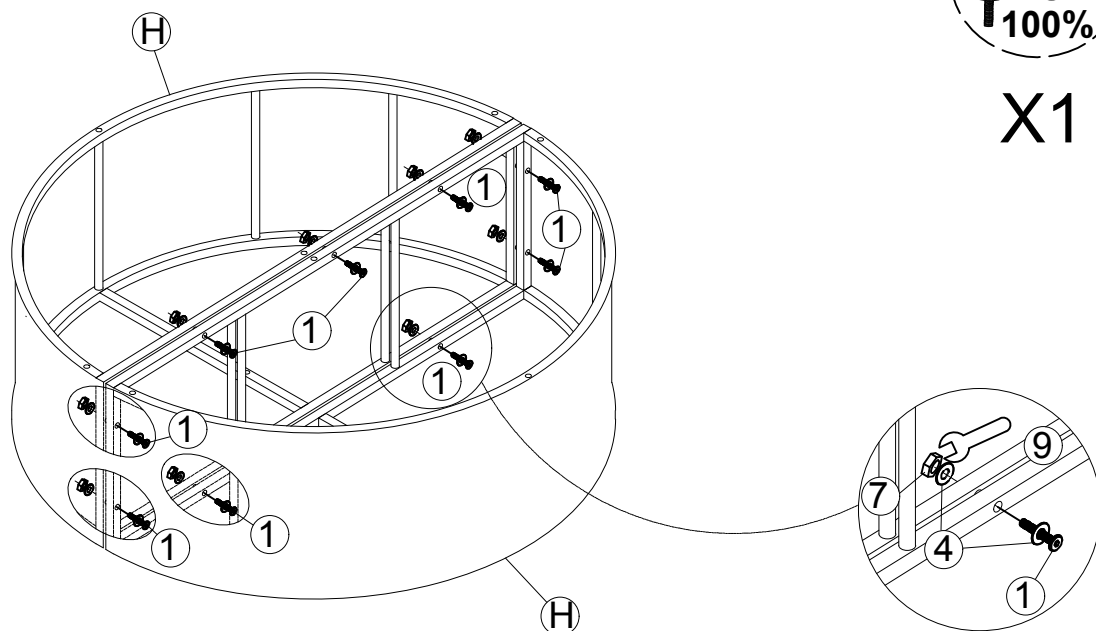

Connect Stool Frame (H) with Bolt (1), washer (4), Ecrú (7).

# STEP 7

1 x1

3 x2

4 x2

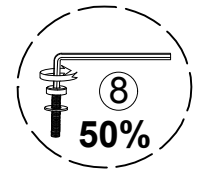

X1

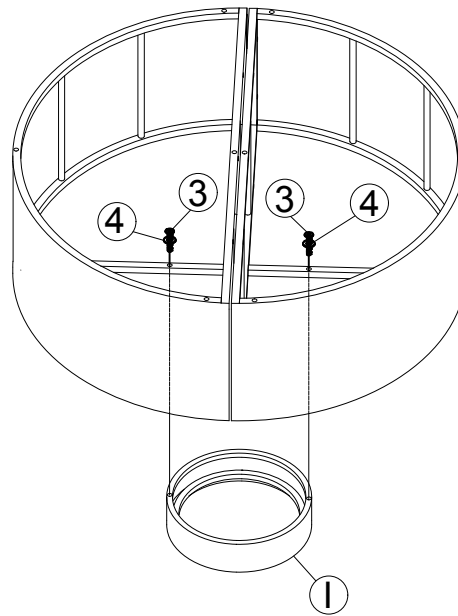

Connect the Part from Step 6 & Tray (1) with Bolt (3), washer (4).

# STEP 8

6 x8

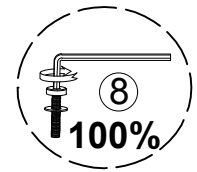

X1

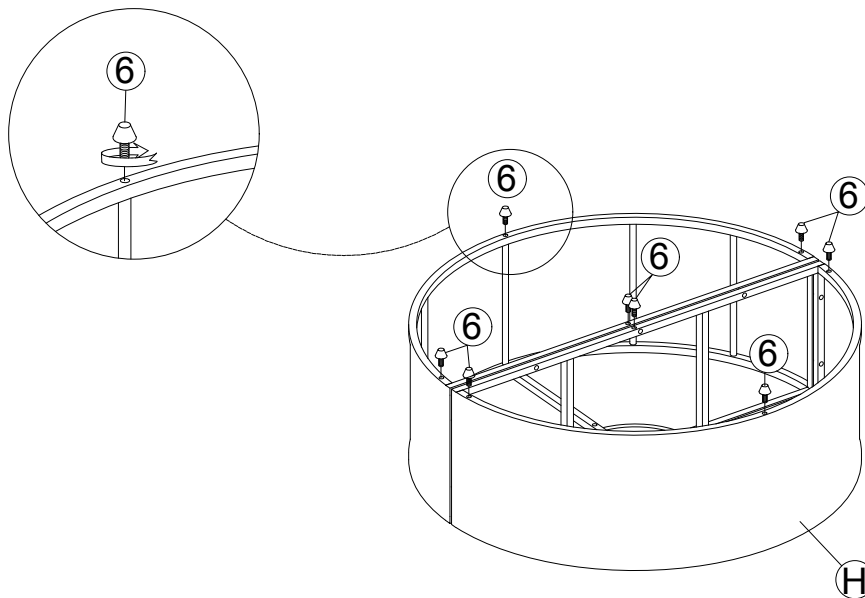

Connect the Part from Step 7 & Adjustable Feet (6) by Hand.



## STEP 9

I x1

J x1

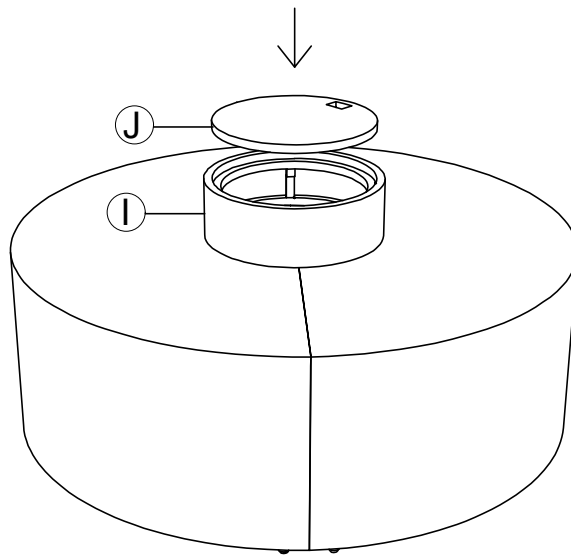

X1

Put the Top Tray (J) inside Tray (I) by Hand.

## STEP 10

K x1

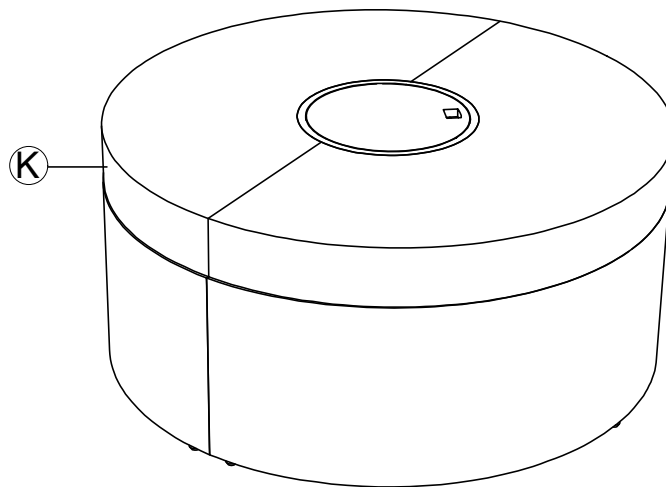

X1

Put the Seat Stool Cushion (K) to Finish Stool.

# STEP 11

⑥ x4

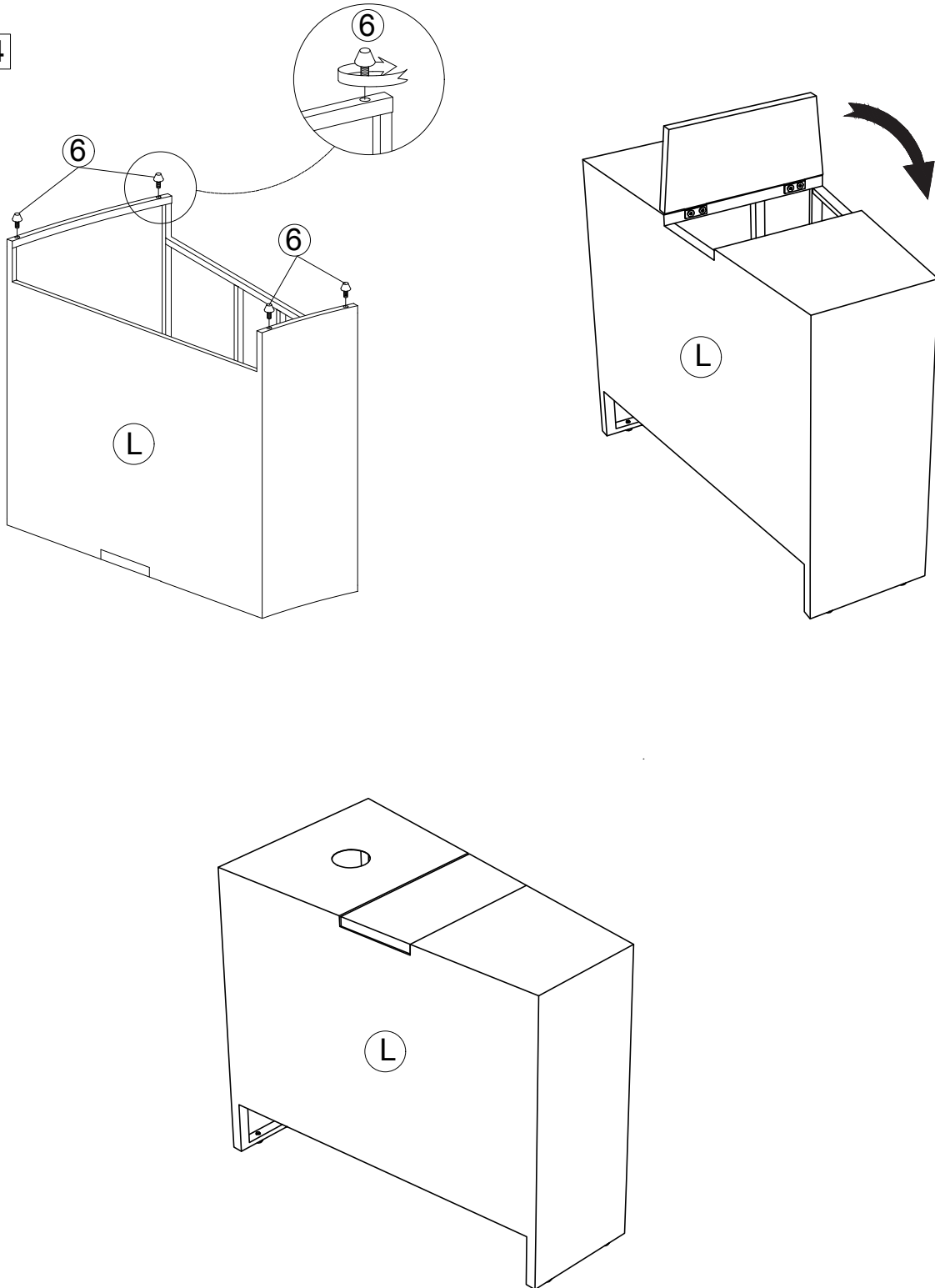

Connect the Side Table (L) & Adjustable Feet (6) by Hand.

# STEP 12

⑤ x8

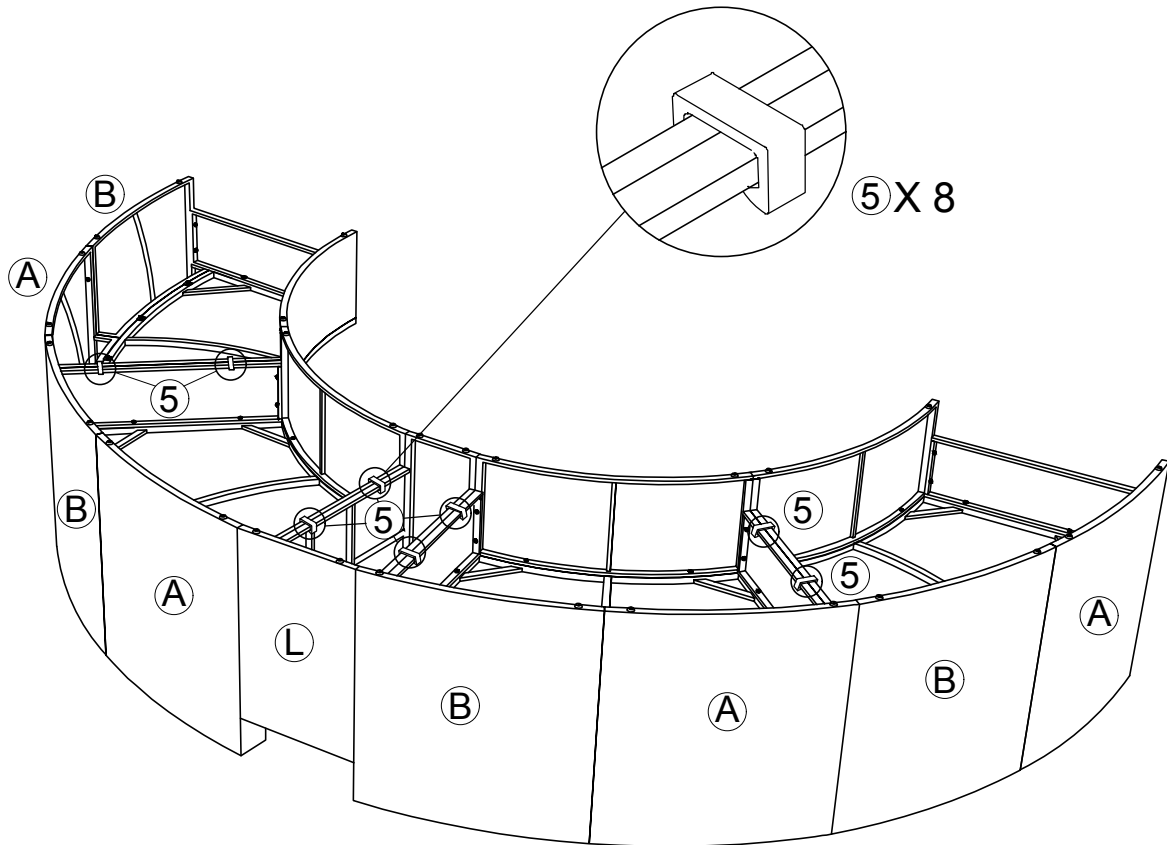

Connect the Bench & Side Table (M) with Connector (5) by Hand.

# STEP 13

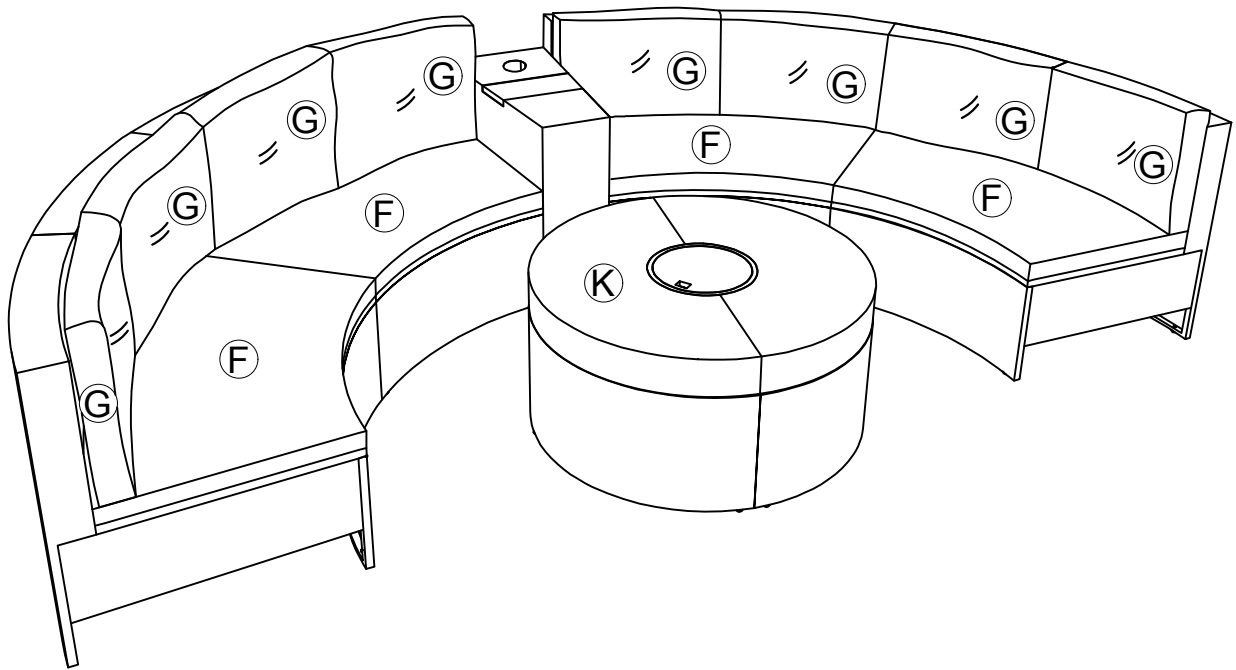

Finish.