

ASSEMBLY INSTRUCTION

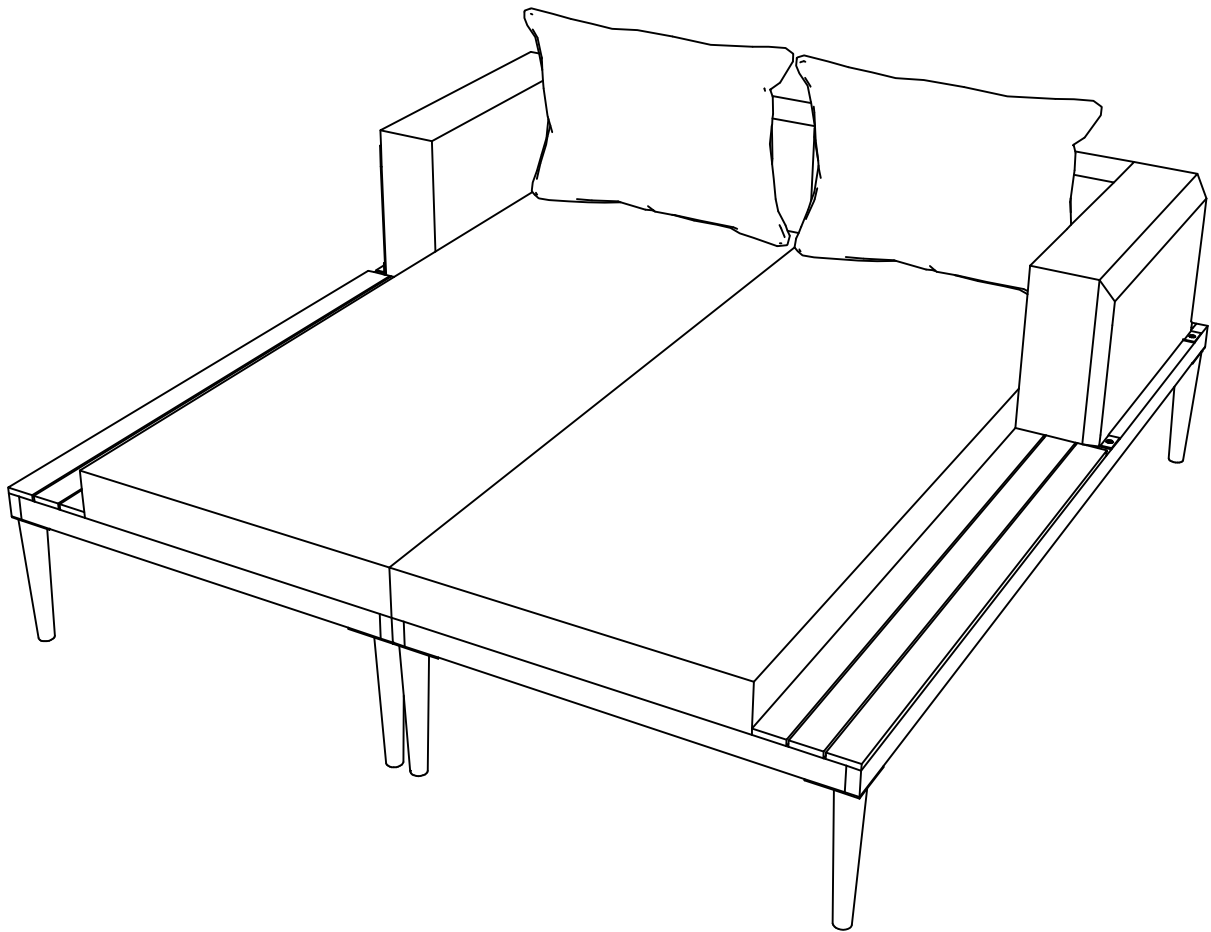

WF316839

WF316840

Notice:

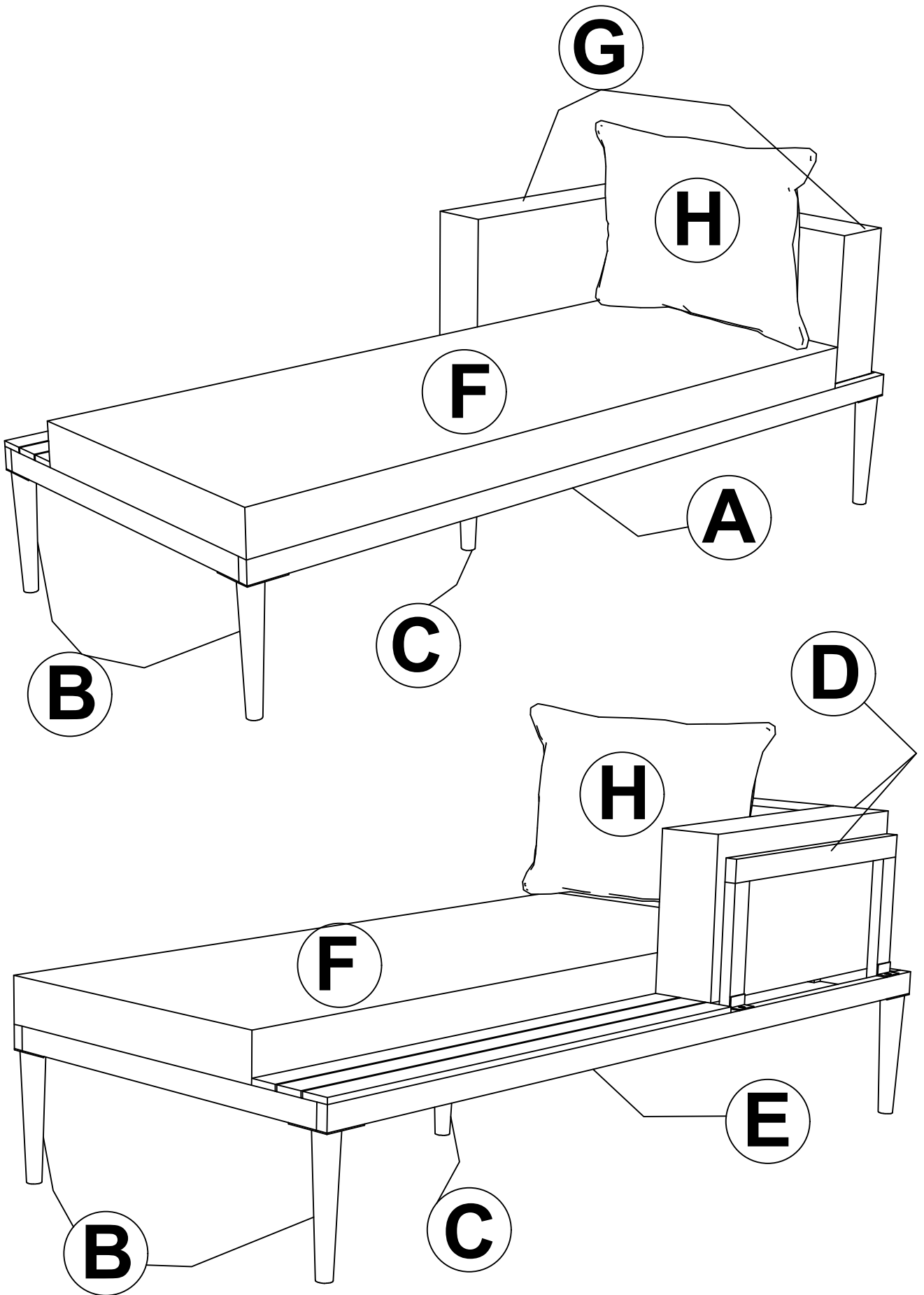

1. 50% Tighten before fixing all screws, Allen wrench is recommended instead of an electric drill.
2. Place the item on a flat ground to adjust and make sure it remains stable.
3. Tighten up all screws with tools gradually.
4. If the screws are not aligned with holes during assembly, please loosen all the other screws to 50% and continue the assembly process.
5. If the item is not stable, please loosen all the screws, adjust it on a flat ground and tighten up all screws again.
6. Note : If one or some screws are fully tightened during assembly, chances are the others will not be aligned with holes. In addition, all the holes are designed to be relatively larger to provide more space for the adjustment of the screws.

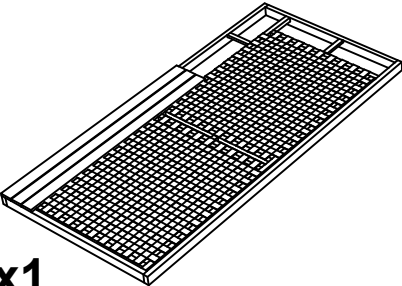
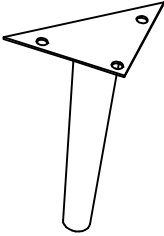
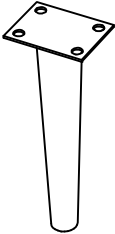
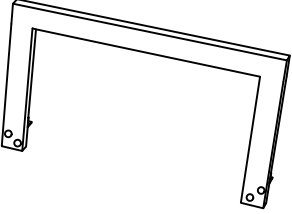
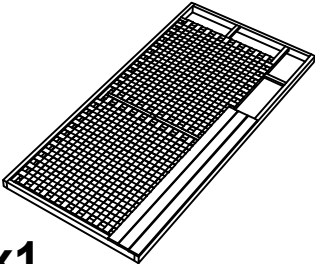
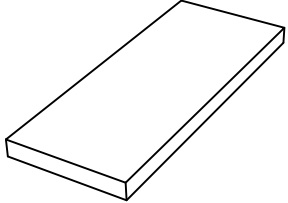
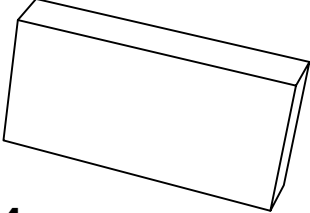
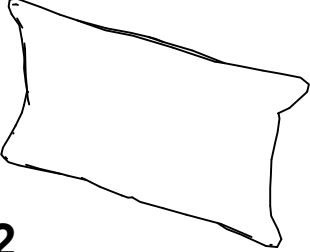

PART LIST

 <p>Ax1</p>	 <p>Bx8</p>	 <p>Cx2</p>
 <p>Dx4</p>	 <p>Ex1</p>	 <p>Fx2</p>
 <p>Gx4</p>	 <p>Hx2</p>	

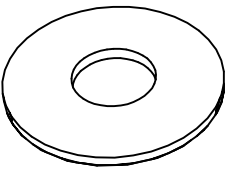
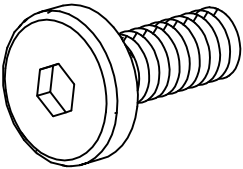
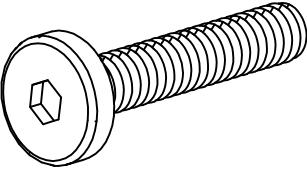
HARDWARE LIST

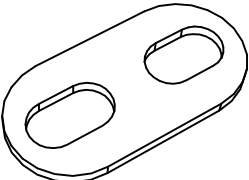
 <p>1- Washer : 60 pcs Extra : 2 pcs</p>	 <p>2- Bolt 6x15 : 44 pcs Extra : 2 pcs</p>	 <p>3- Bolt 6x35 : 16 pcs Extra : 2 pcs</p>	 <p>4- Allen key : 2</p>
 <p>5- Bracket : 2 pcs</p>			

CARTON CONTENT

WF316839

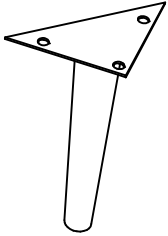

Bx8

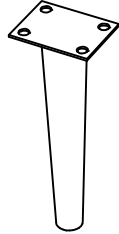

Cx2

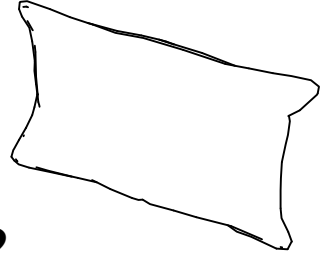

Hx2

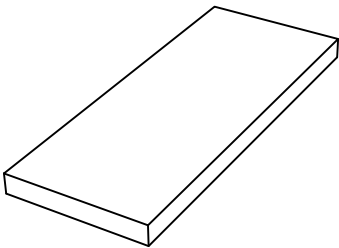

Fx2

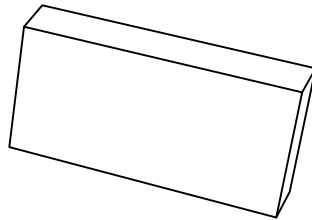

Gx4

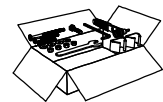

Hardware

WF316840

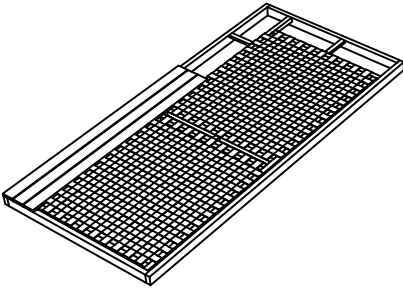

Ax1

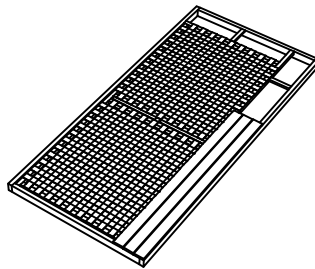

Ex1

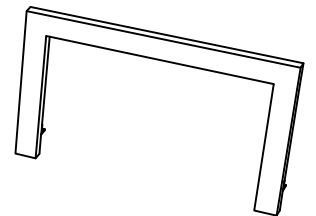

Dx4

Step 1

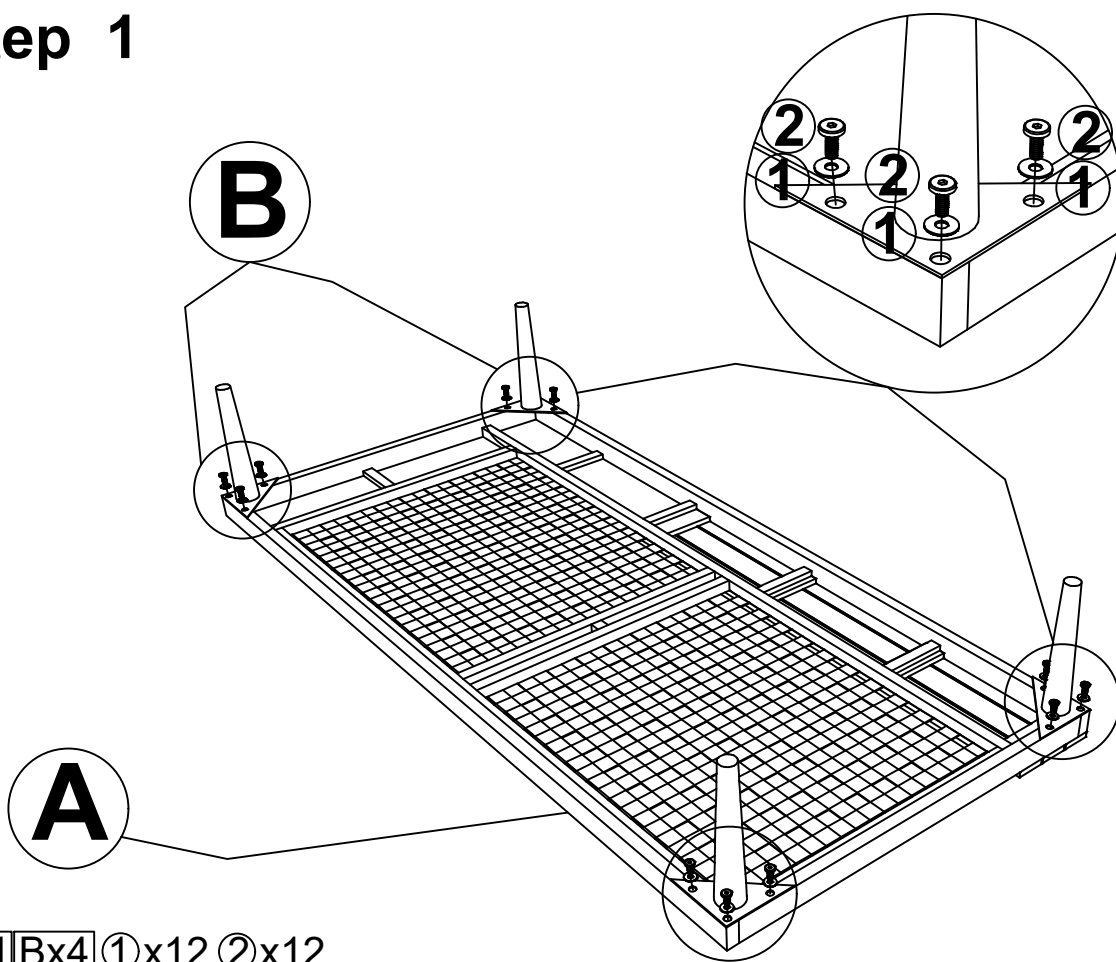

Ax1 Bx4 ①x12 ②x12

Step 2

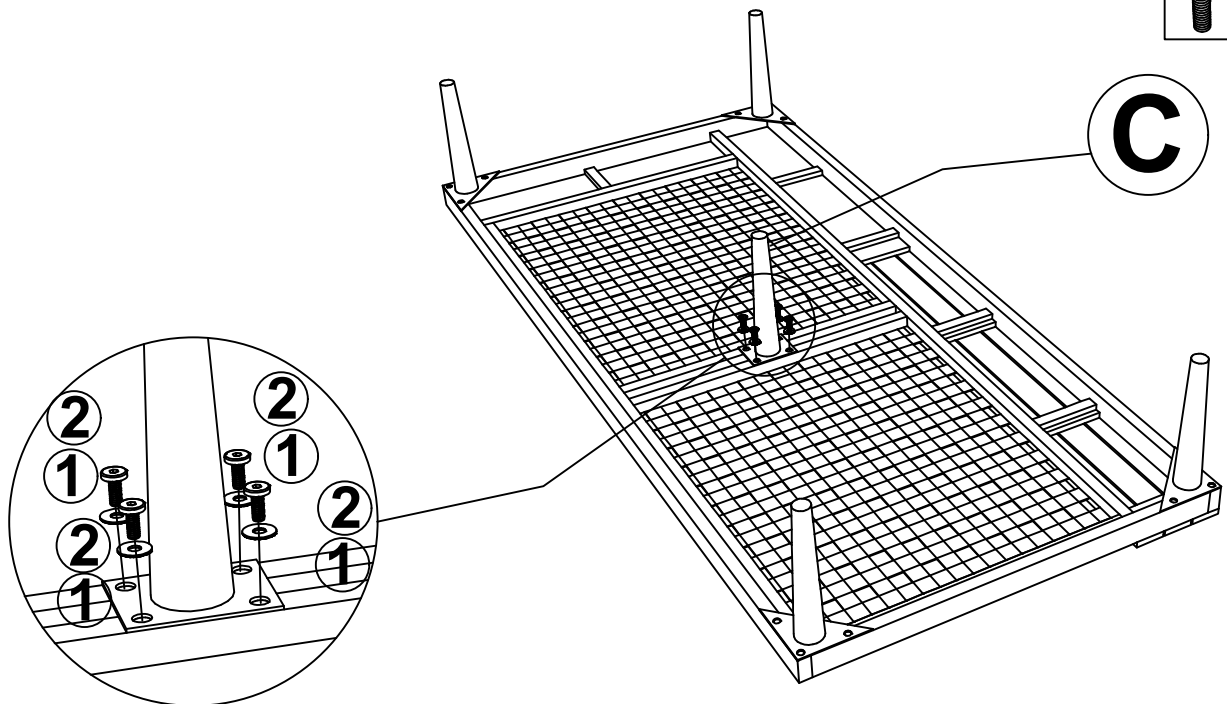

Cx1 ①x4 ②x4

Step 3

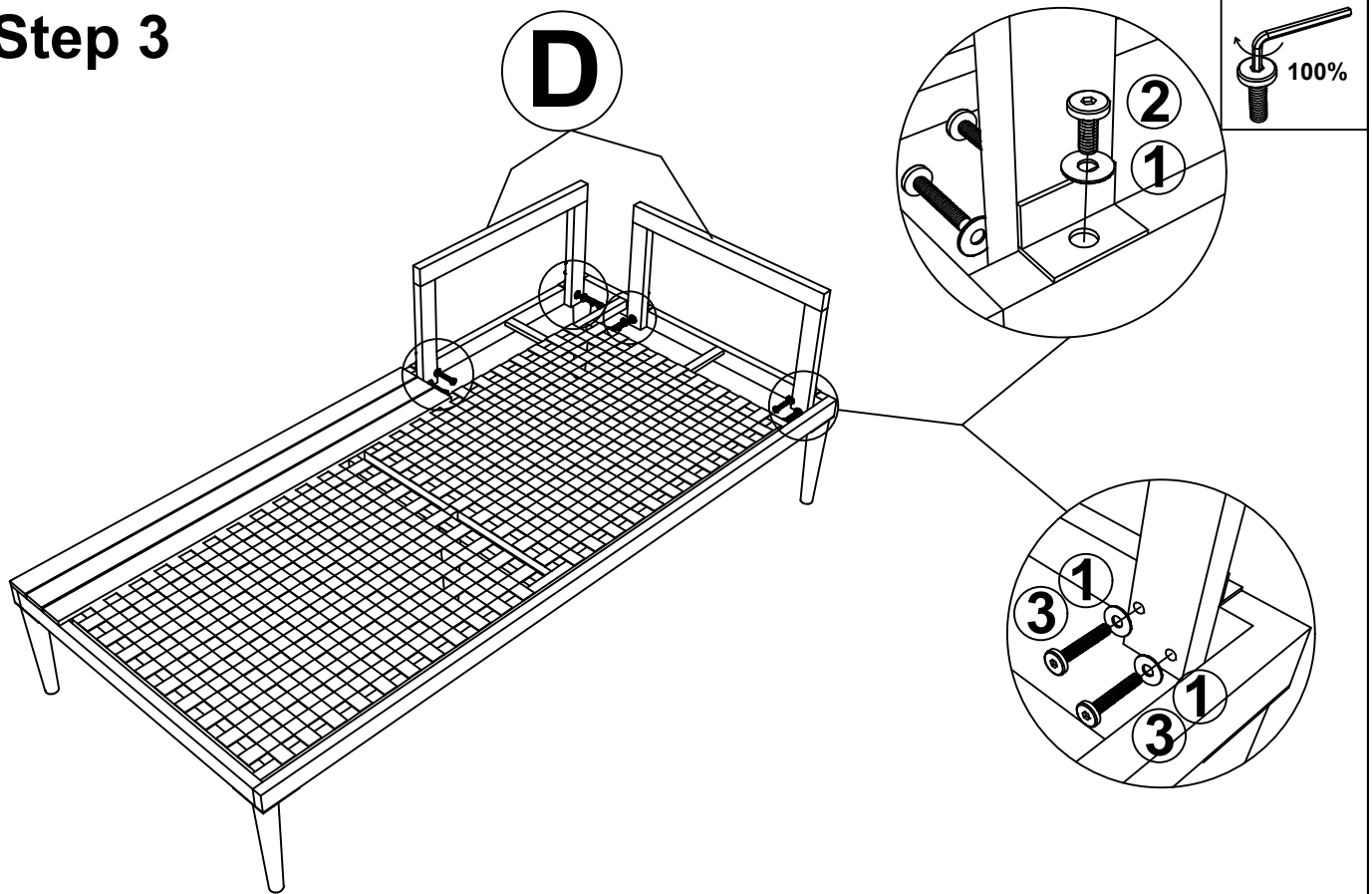

Dx2 ①x12 ②x4 ③x8

Step 4

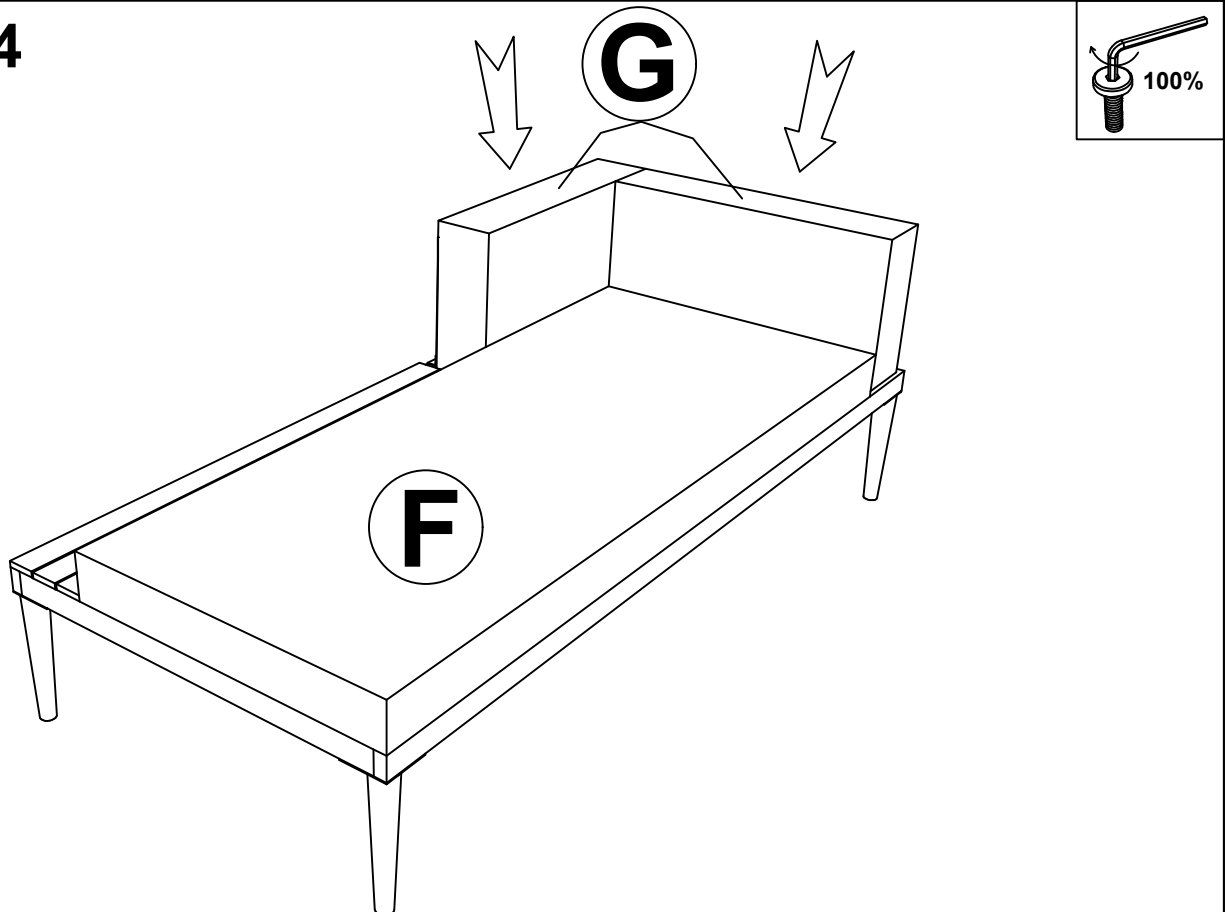

Fx1 Gx2

Step 5

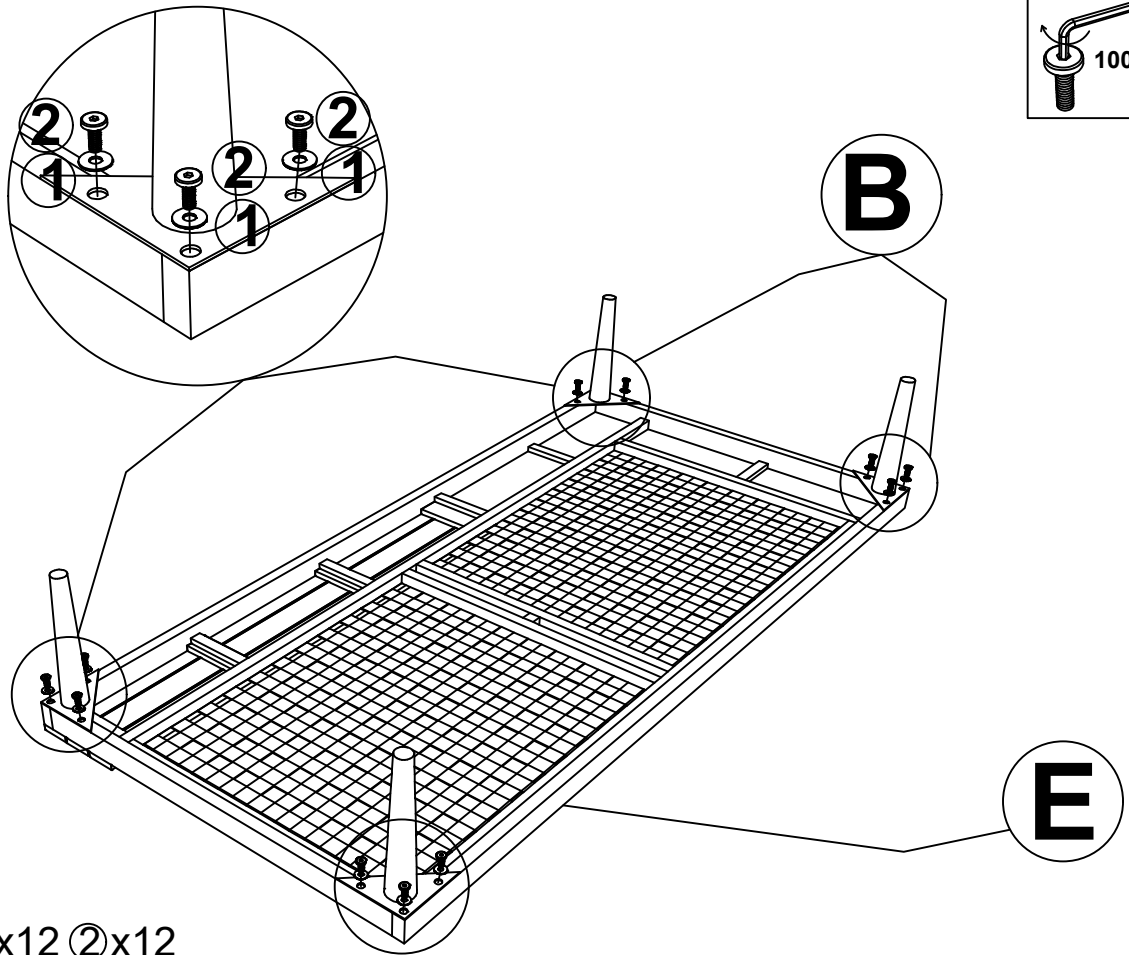

Ex1 Bx4 ①x12 ②x12

Step 6

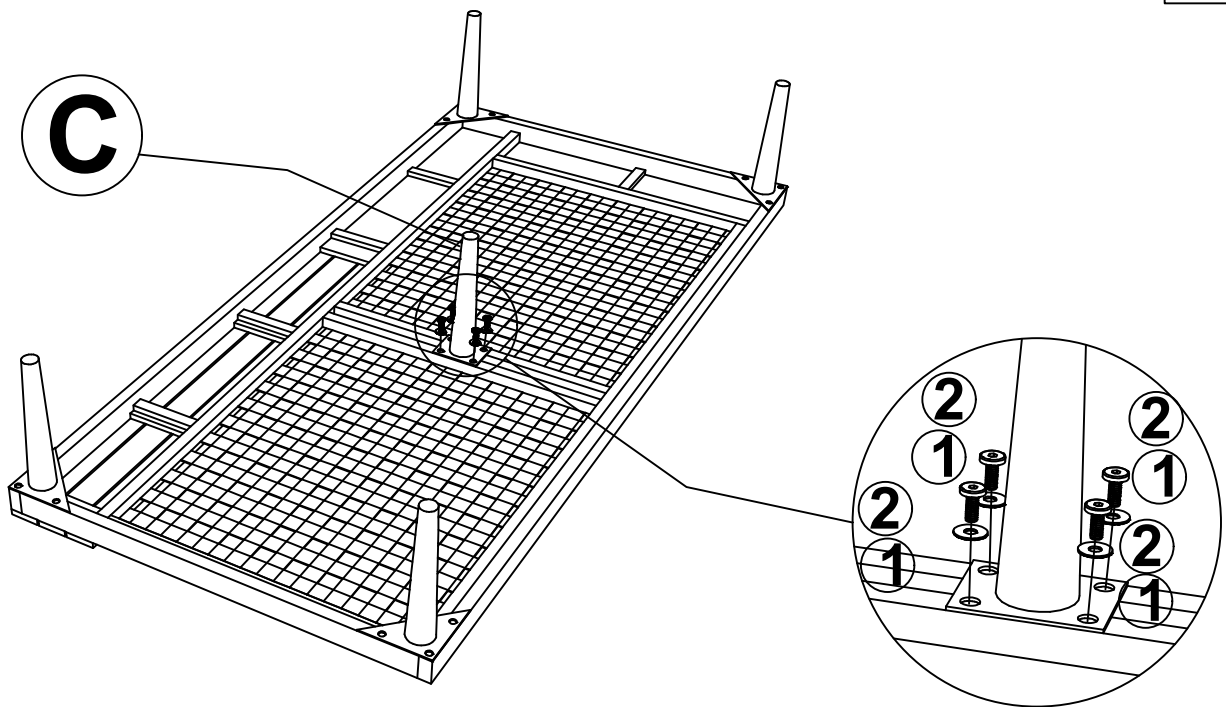

Cx1 ①x4 ②x4

Step 7

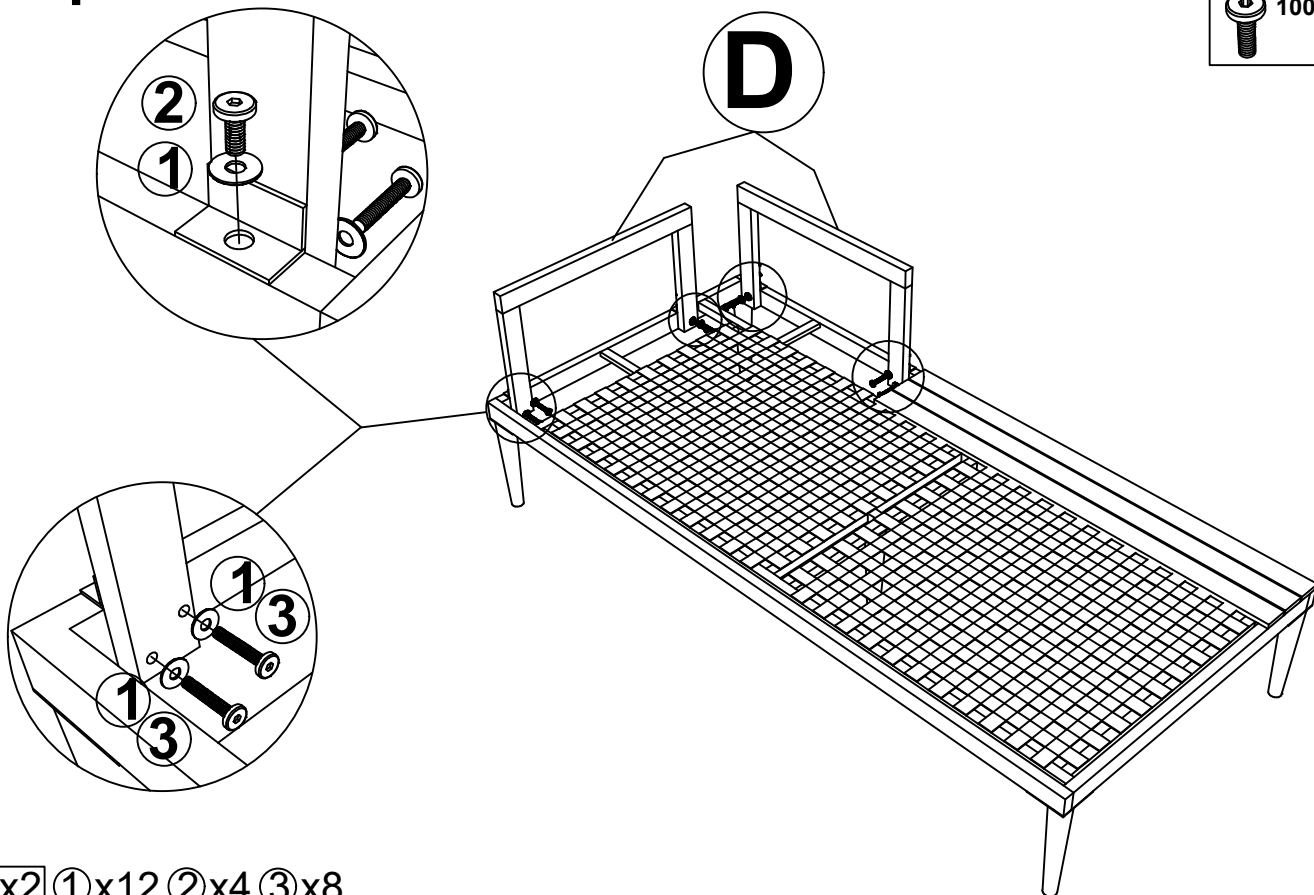
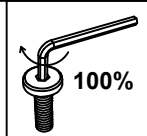

Dx2 ①x12 ②x4 ③x8

Step 8

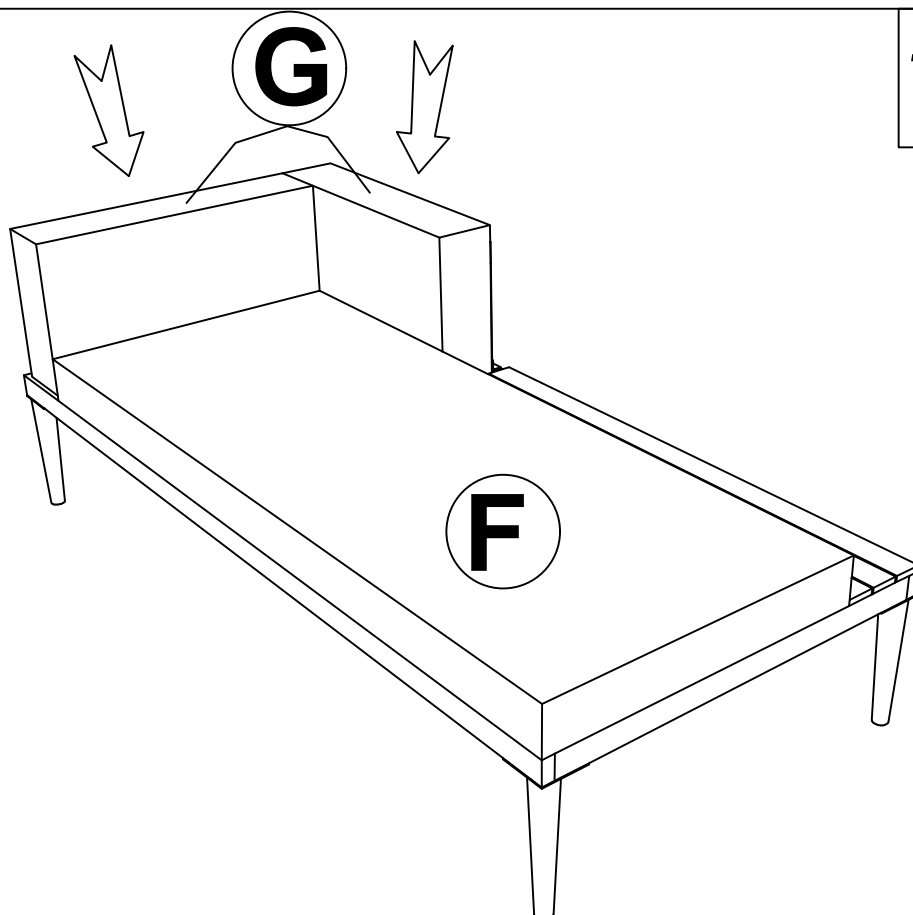
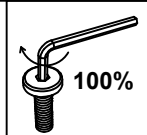

Fx1 Gx2

Step 9

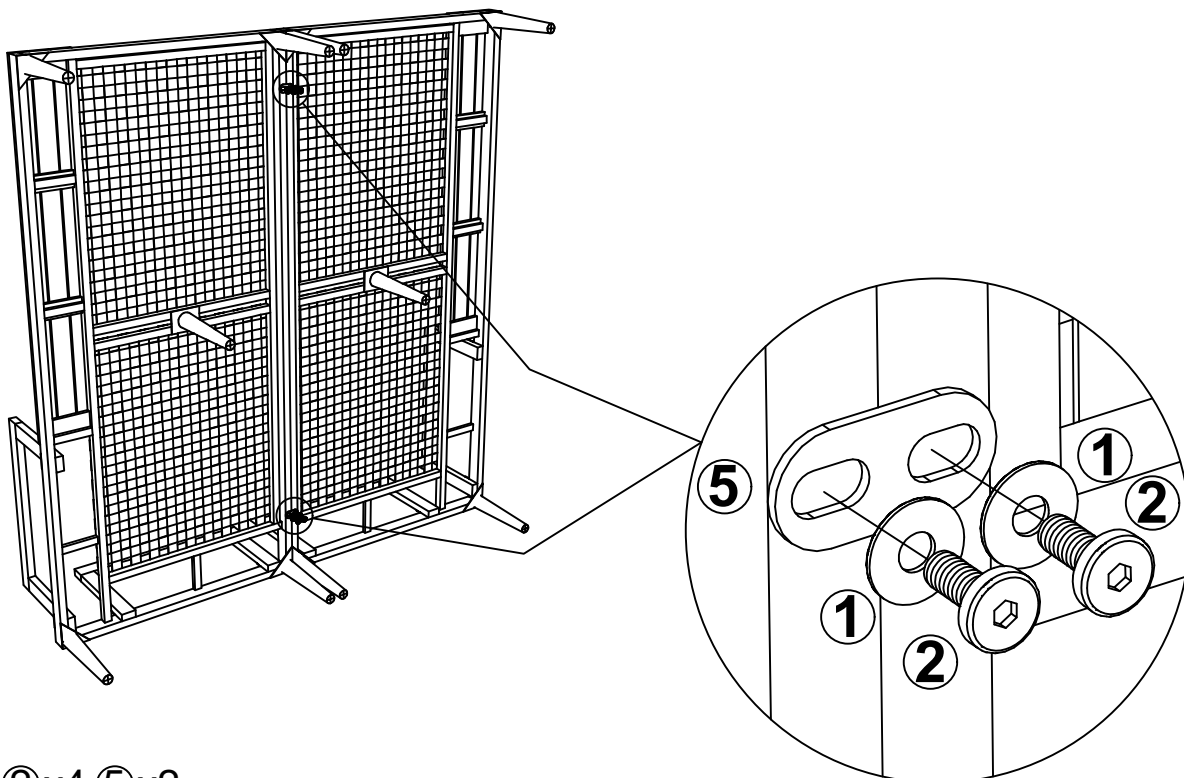
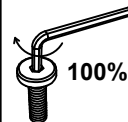

①x4 ②x4 ⑤x2

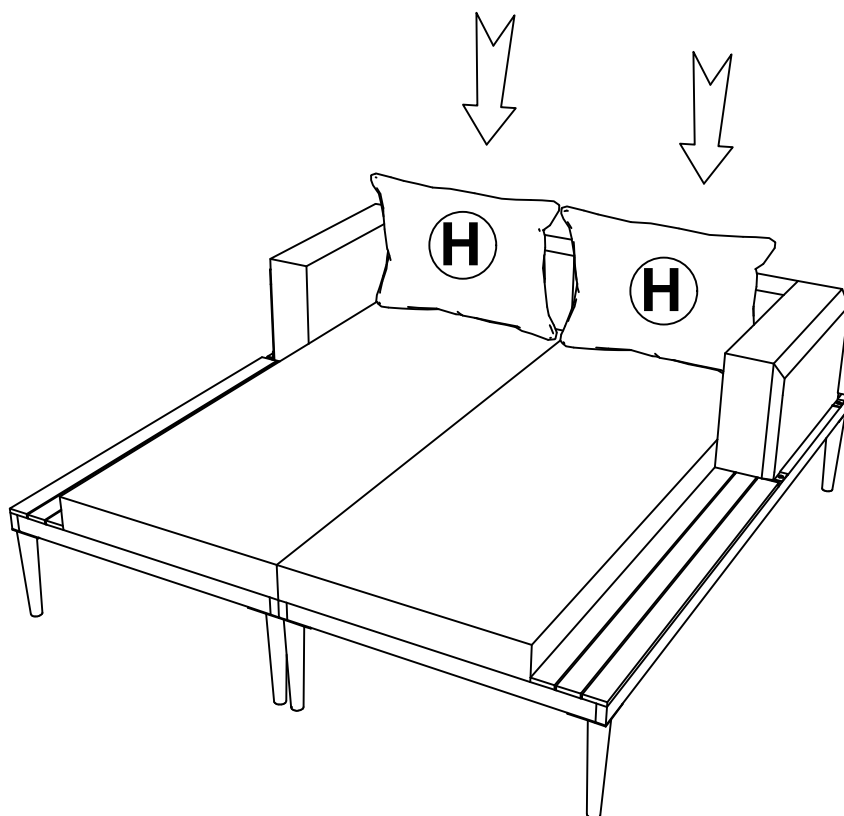

Hx2

Finish