

ASSEMBLY INSTRUCTIONS

OUTDOOR DINING SET

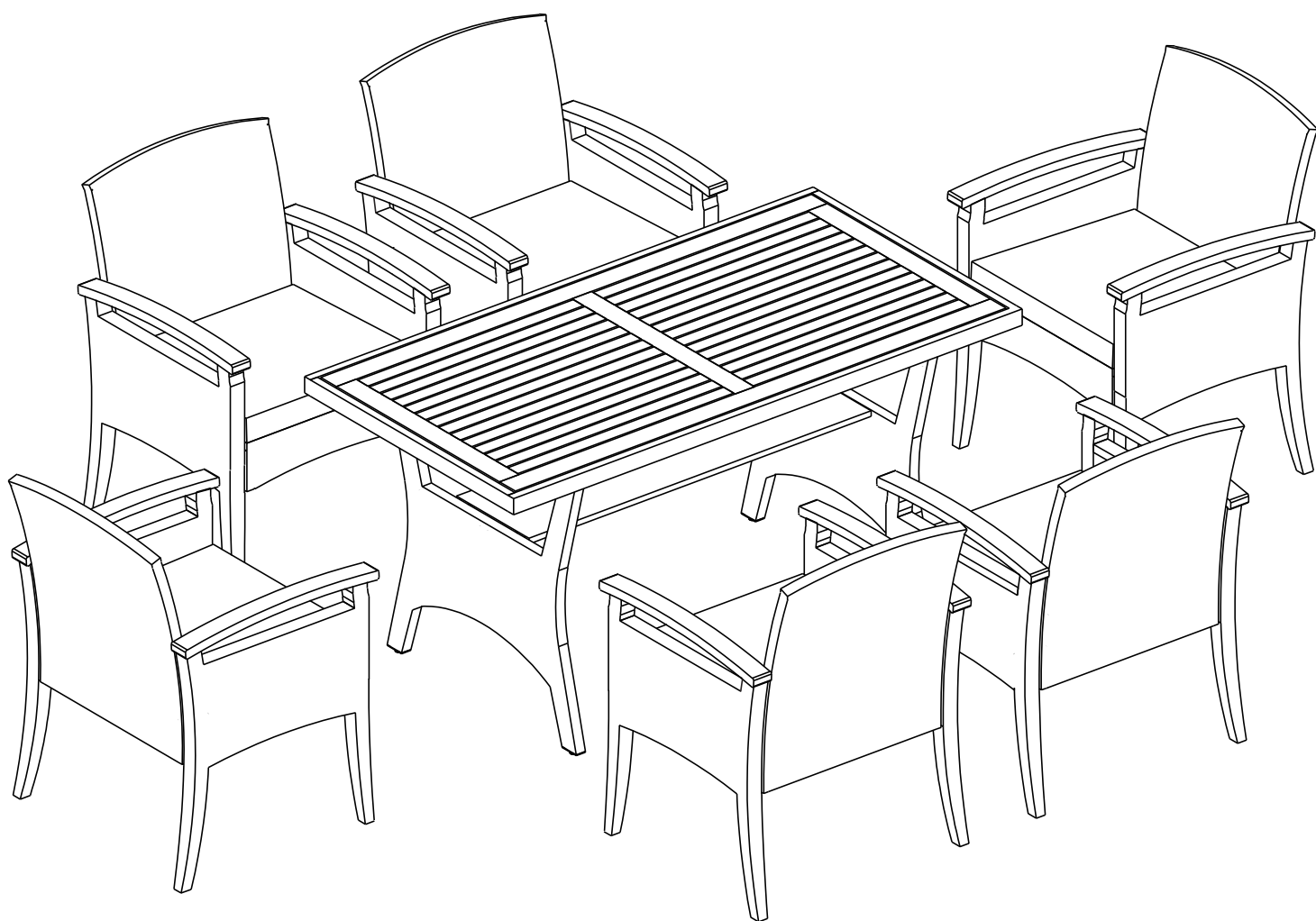

NOTE: 50% TIGHTEN BEFORE FIXING ALL BOLTS

WF302123

WF302124

WF302125

(6 x Single Chair)

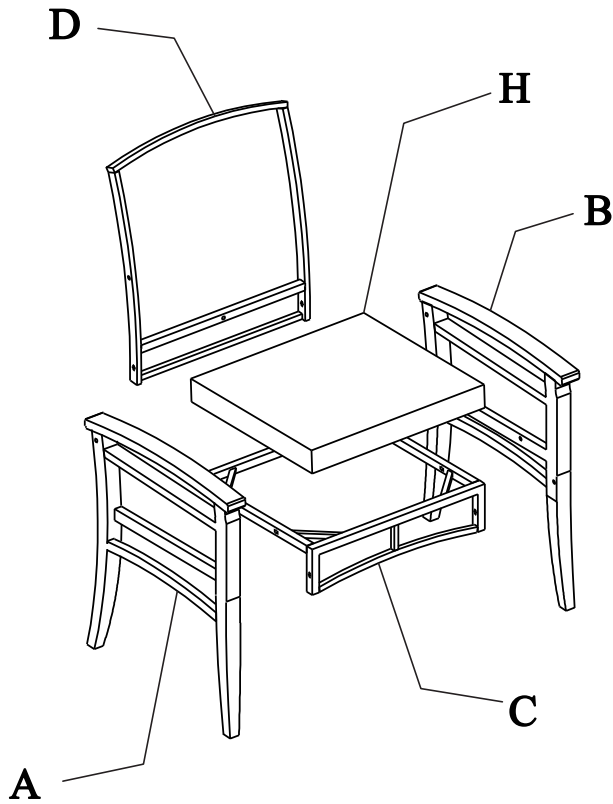

(1 x Table)

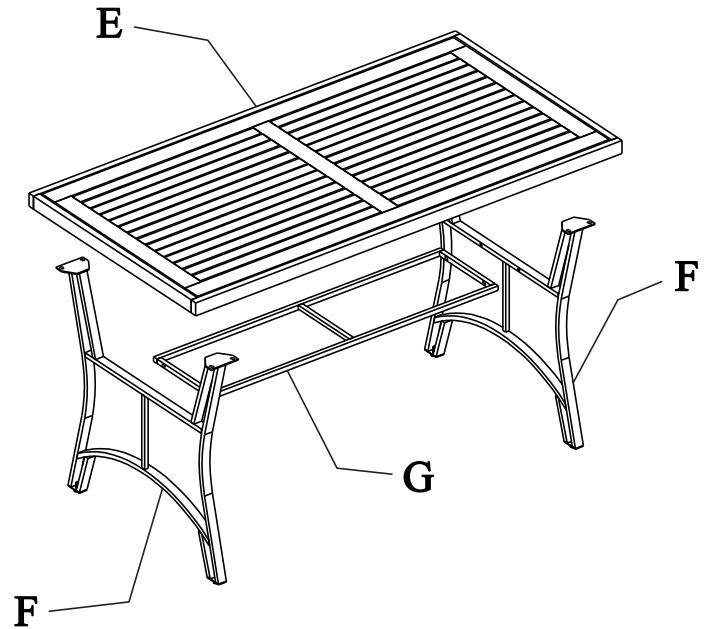



Notice:

1. 50% Tighten before fixing all screws, Allen wrench is recommended instead of an electric drill.
2. Place the item on a flat ground to adjust and make sure it remains stable
3. Tighten up all screws with tools gradually.
4. If the screws are not aligned with holes during assembly, please loosen all the other screws to 50% and continue the assembly process.
5. If the item is not stable, please loosen all the screws, adjust it on a flat ground and tighten up all screws again.
6. Note : If one or some screws are fully tightened during assembly, chances are the others will not be aligned with holes. In addition, all the holes are designed to be relatively larger to provide more space for the adjustment of the screws.

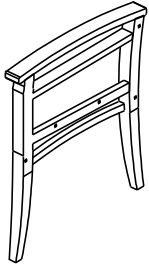
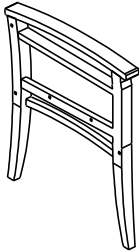
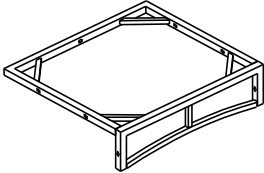
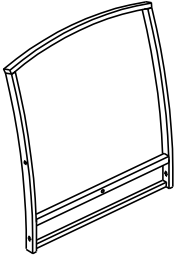
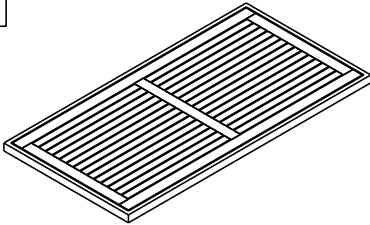
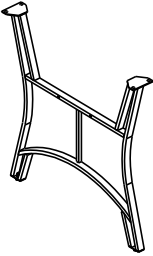
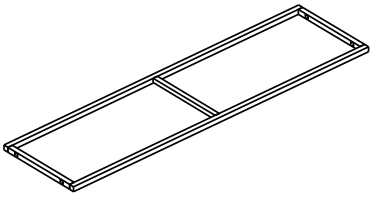
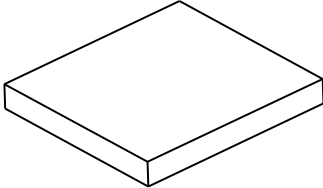
Part List

<p>A</p>  <p>Right Frame (6 pcs)</p>	<p>B</p>  <p>Left Frame (6 pcs)</p>	<p>C</p>  <p>Seat Frame (6 pcs)</p>
<p>D</p>  <p>Back Frame (6 pcs)</p>	<p>E</p>  <p>Table Top Frame (1 pc)</p>	<p>F</p>  <p>Table Leg Frame (2 pcs)</p>
<p>G</p>  <p>Table Shelf Frame (1 pc)</p>	<p>H</p>  <p>Seat Cushion (6 pcs)</p>	

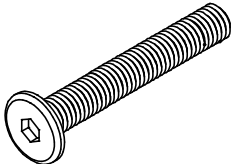
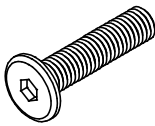
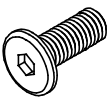
Hardware List

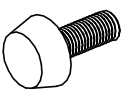
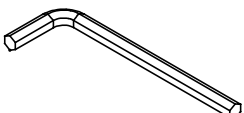
<p>1</p>  <p>Bolt M6 x 55 mm 12 pcs + extra 2 pcs</p>	<p>2</p>  <p>Bolt M6 x 40 mm 58 pcs + extra 3 pcs</p>	<p>3</p>  <p>Bolt M6 x 15 mm 8 pcs + extra 1 pc</p>
<p>4</p>  <p>M6 x 1 mm Washers 78 pcs + extra 3 pcs</p>	<p>5</p>  <p>Foot pad M6 x 20 mm 28 pcs + extra 2 pcs</p>	<p>6</p>  <p>Allen key M4 (2 pcs)</p>

CARTON CONTENT:

WF302123

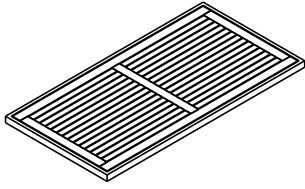

E x 1

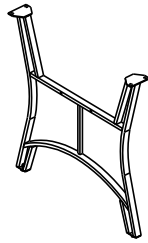

F x 2

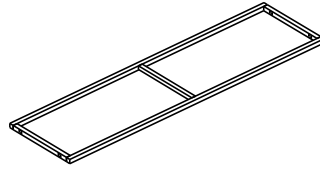

G x 1



HARDWARE

WF302124



A x 3

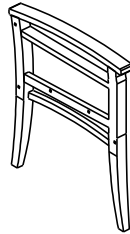

B x 3

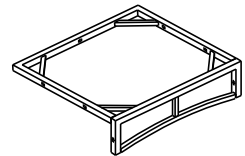

C x 3

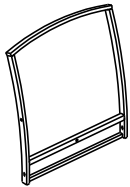

D x 3

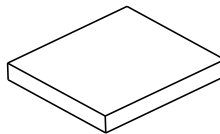

H x 3

WF302125



A x 3

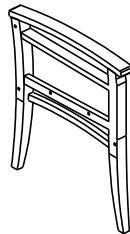

B x 3

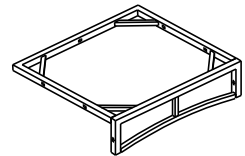

C x 3

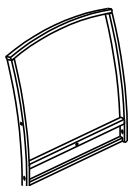

D x 3

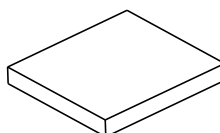

H x 3

STEP 1 (6 x Chair assembly)

Connect Back Frame (D) & Seat Frame (C) with Bolt (2) & Washer (4)

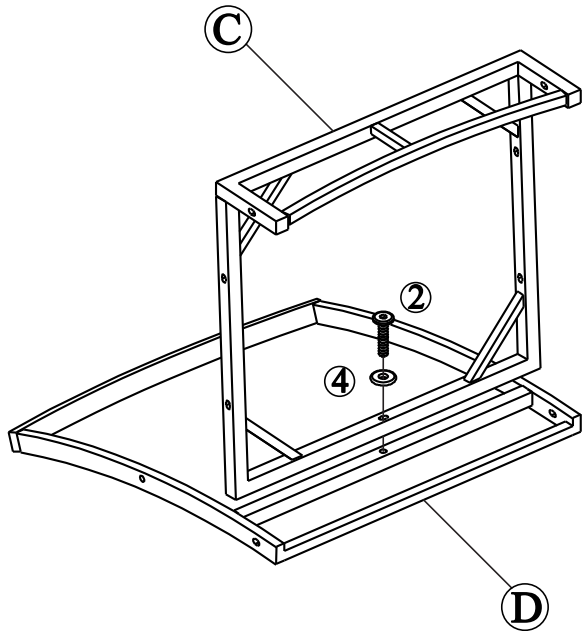

②*1 ④*1 C*1 D*1

STEP 2

Connect part from Step 1 & Left Frame (B) with Bolt (2) & Washer (4)

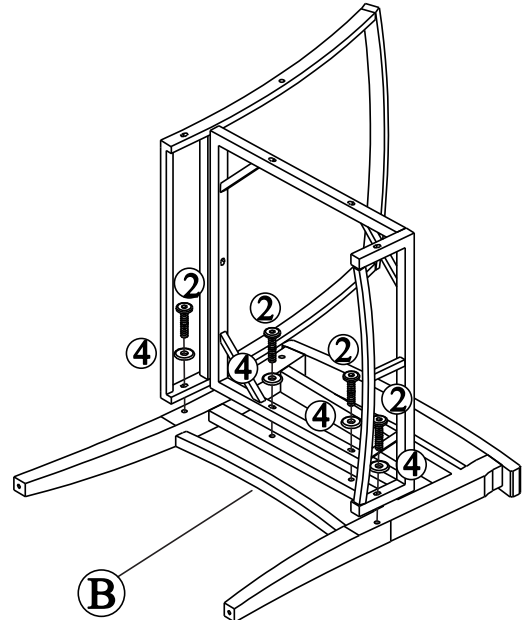

②*4 ④*4 B*1

STEP 3

Connect part from Step 2 & Right Frame (A) with Bolt (2) & Washer (4)

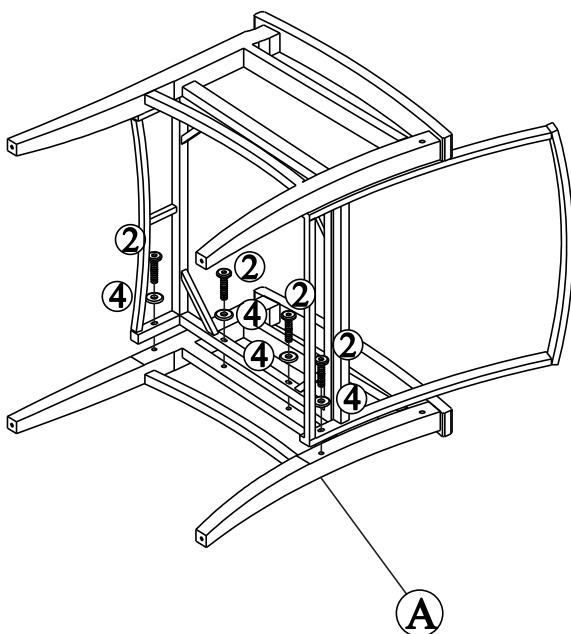

②*4 ④*4 A*1

STEP 4

Connect Right Frame (A), Left Frame (B) & part from Step 1 with Bolt (1) & Washer (4)

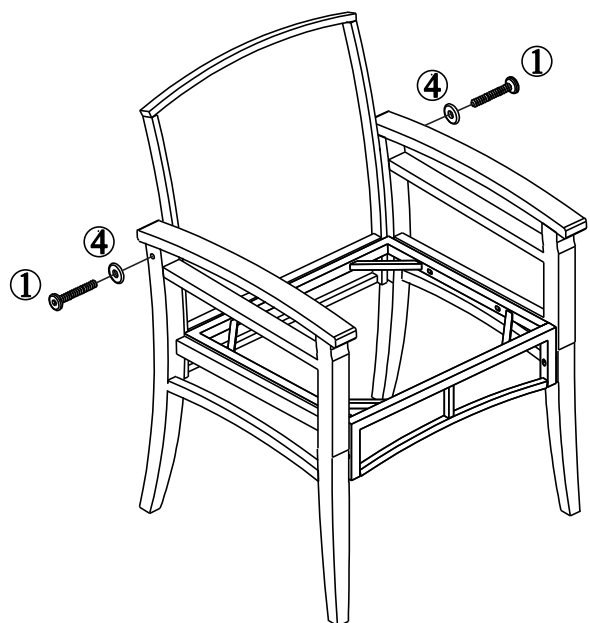

①*2 ④*2

STEP 5

Connect part from Step 4 with Foot pad (5)

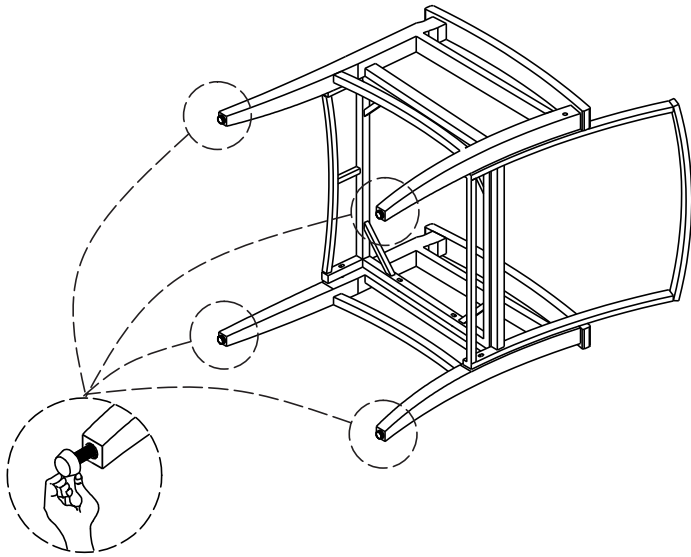

5*4

STEP 6

Put on Seat Cushion (H) to complete Chair

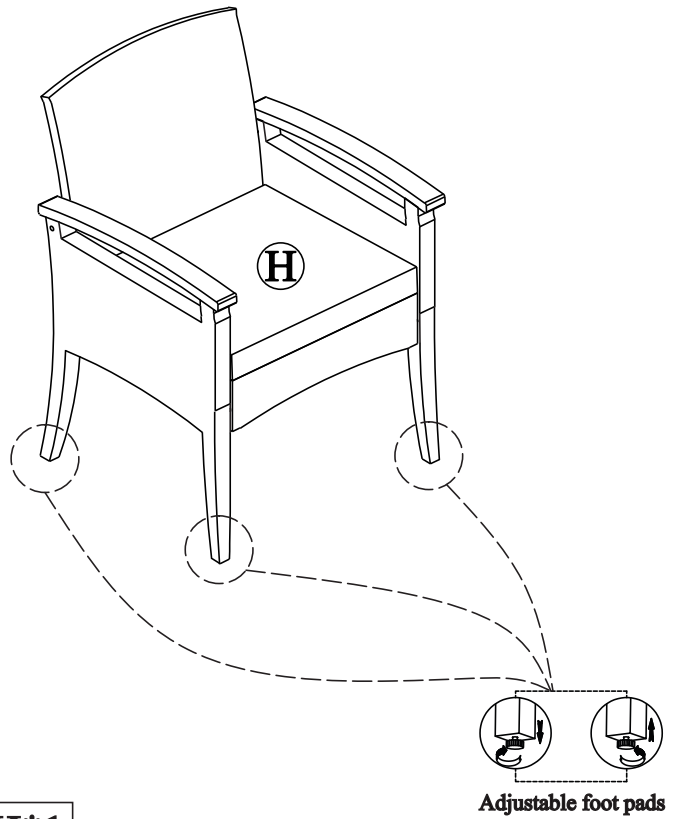

H*1

Adjustable foot pads

STEP 7 (1 x Table assembly)

Connect Table Top Frame (E) & Table Leg Frame (F) with Bolt (3) & Washer (4)

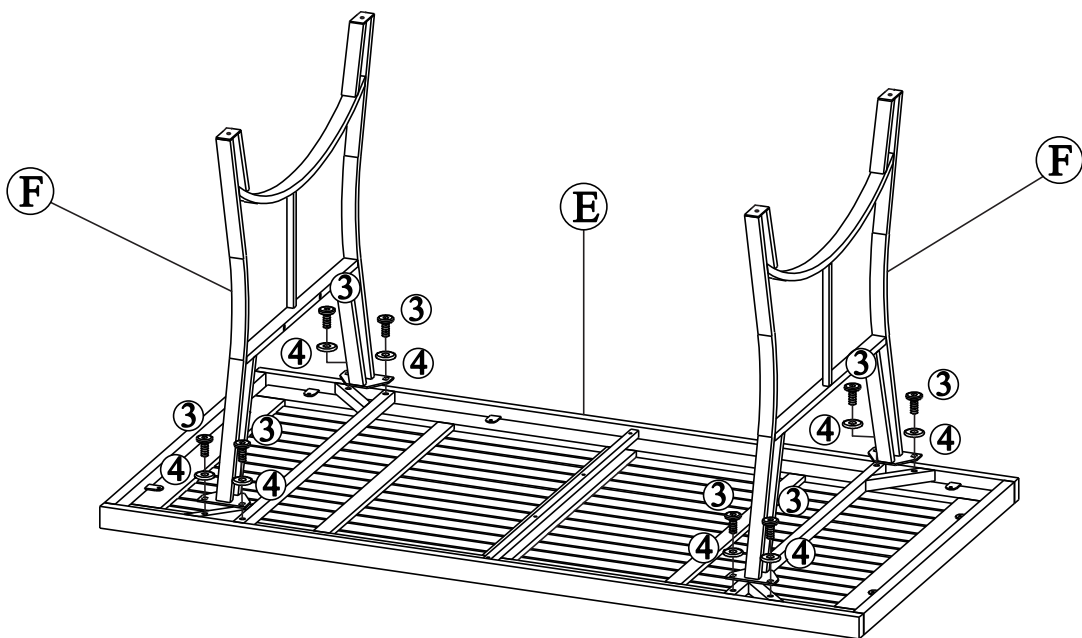

3*8 4*8 E*1 F*2

STEP 8

Connect Table Shelf Frame (G) & part from Step 7 with Bolt (2) & Washer (4)

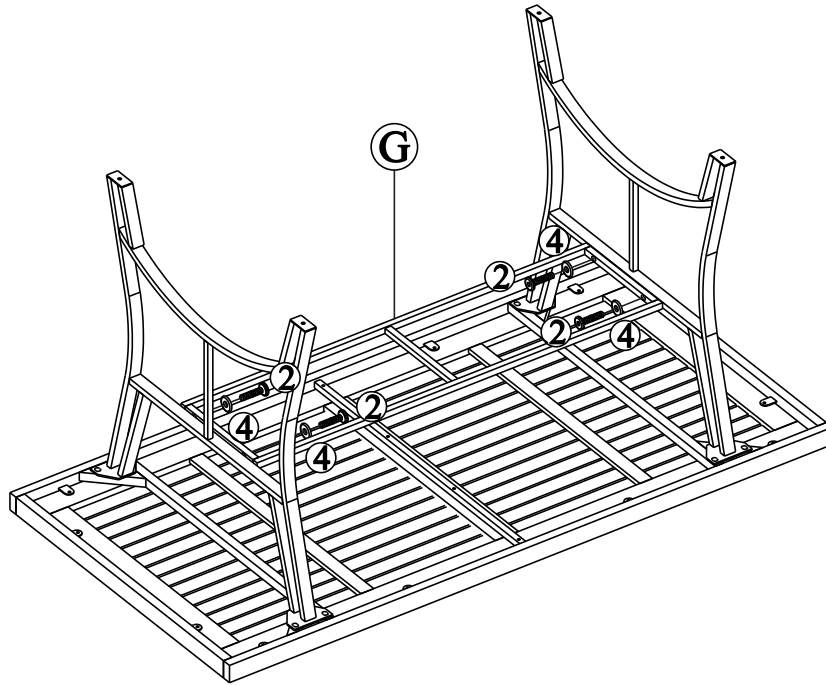

②*4 ④*4 G*1

STEP 9

Connect part from Step 8 with Foot pad (5)

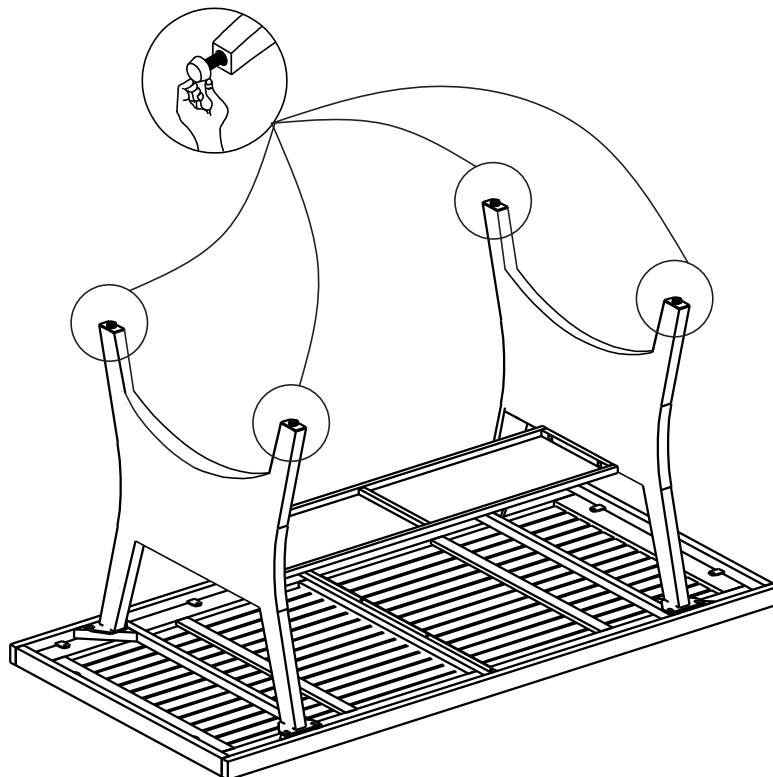

⑤*4

STEP 10

Table assembly have completed

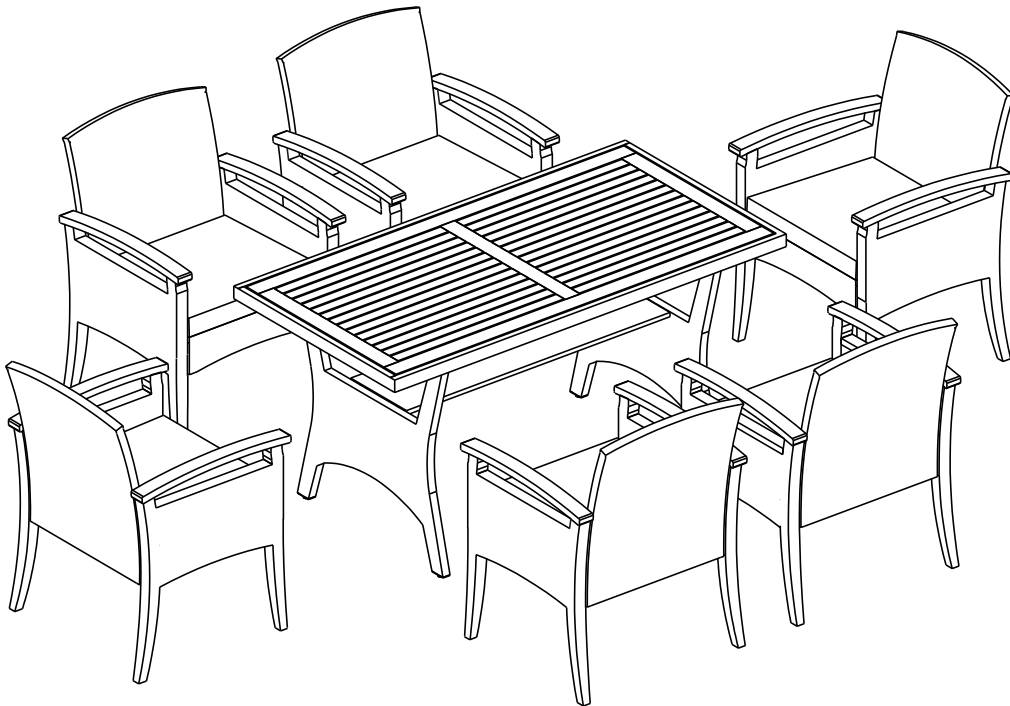
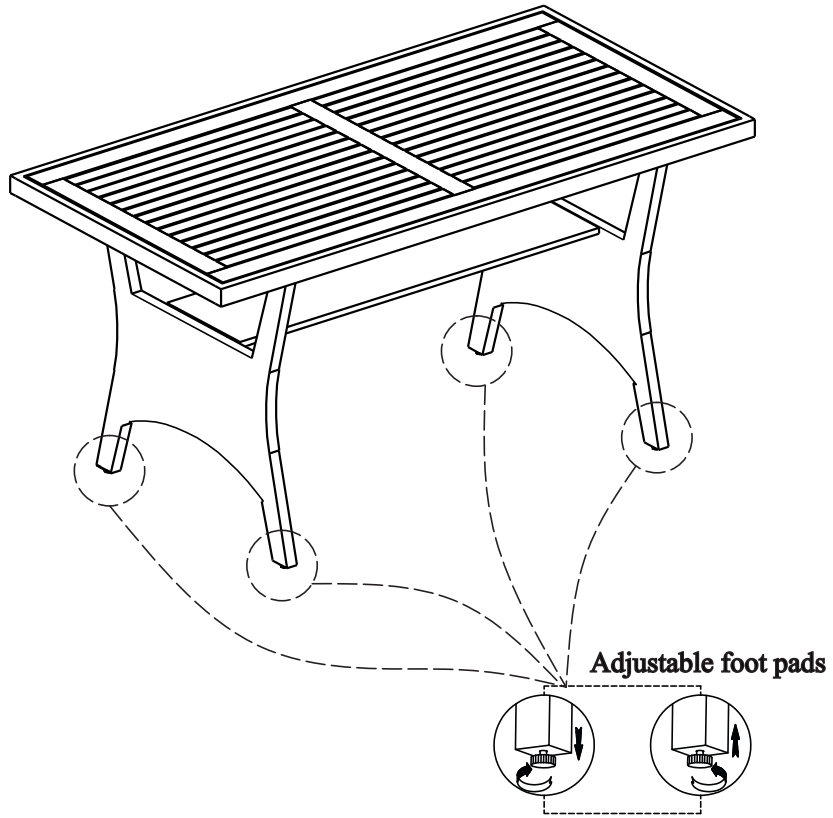

FINISH