

# ASSEMBLY INSTRUCTIONS

---

## RATTAN SOFA SET

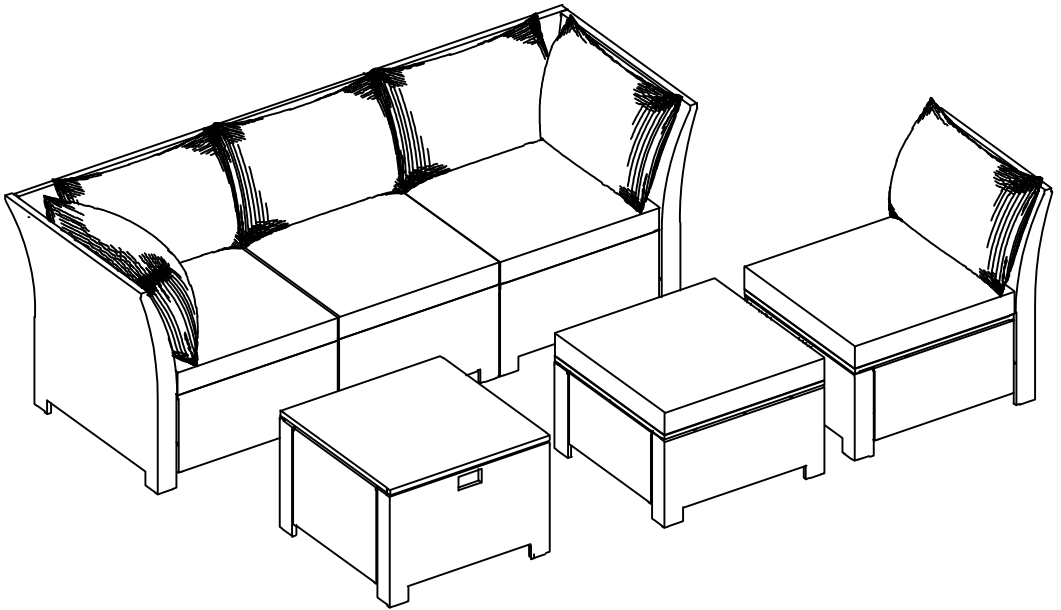

**WF288800, WF288801, WF288802**

x1

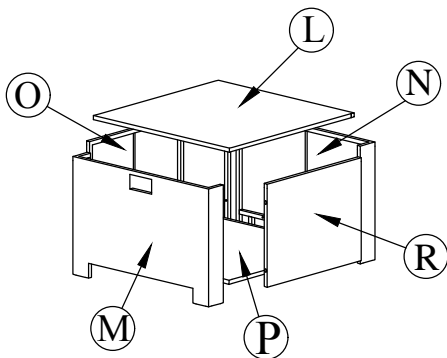

x1

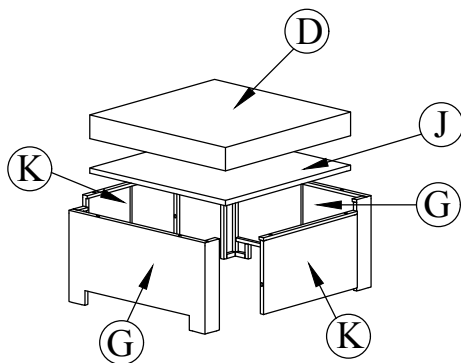

x2

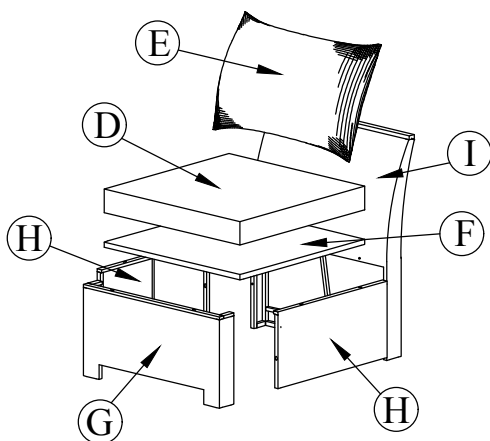

x2

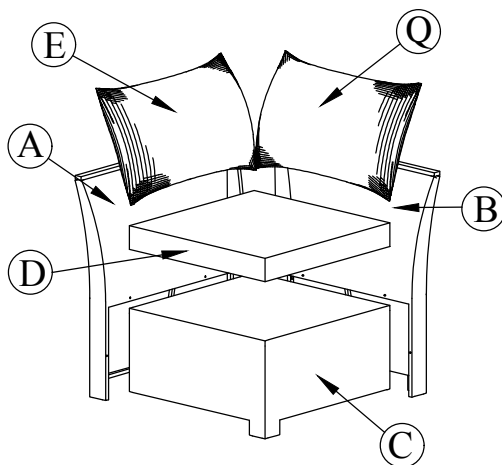

Note:

1. 50% Tighten before fixing all screws, Allen wrench is recommended instead of an electric drill.
2. Place the item on a flat ground to adjust and make sure it remains stable.
3. Tighten up all screw with tools gradually.
4. If screw are not aligned with holes during assembly, please loosen all the other screws to 50% and continue the assembly process.
5. If the item is not stable, please loosen all screws, adjust it on a flat ground and tighten up all screws again.
6. Note: If one or some screws are fully tighten during assembly, chances are the others will not be aligned with holes. In addition, all the holes are designed to be relatively larger to provide more space for the adjustment of the screws.

# CARTON CONTENT:

**WF288800**

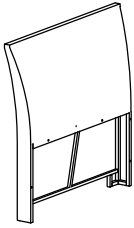

Ⓐx2

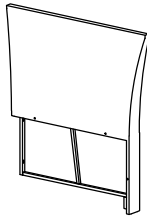

Ⓑx2

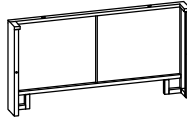

Ⓒ

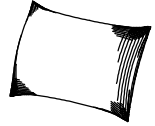

Ⓖx2



HARDWARE

**WF288801**

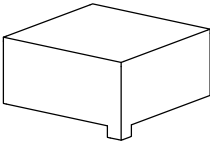

Ⓒx2

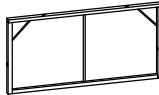

Ⓓx4



Ⓕx2

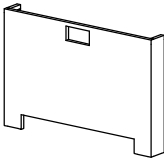

Ⓖx1

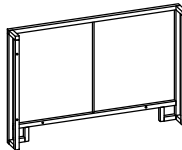

Ⓗx1



Ⓖx5

**WF288803**

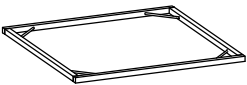

Ⓕx2

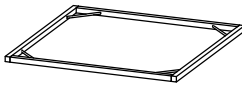

Ⓖx1

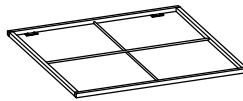

Ⓖx1

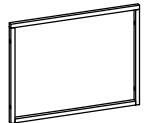

Ⓖx1

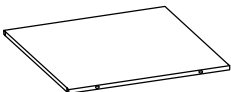

Ⓖx1

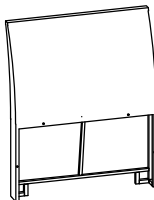

Ⓖx2

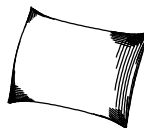



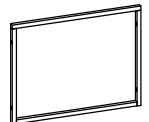



Ⓖx4

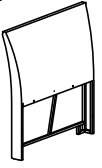
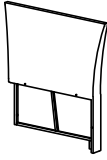
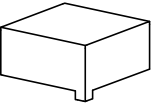
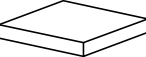

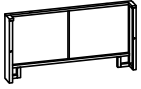
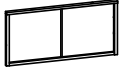
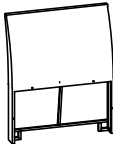

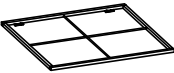
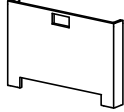
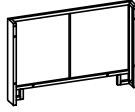
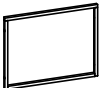
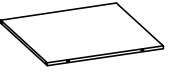

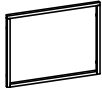

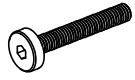

Ⓖx1

# Part List:

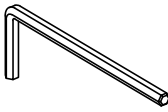
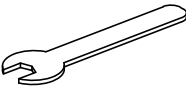
<p><b>(A)</b>x2</p>  <p>Right Corner Frame</p>	<p><b>(B)</b>x2</p>  <p>Back Corner Frame</p>	<p><b>(C)</b>x2</p>  <p>Seat Corner Frame</p>	<p><b>(D)</b>x5</p>  <p>Seat Cushion</p>	<p><b>(E)</b>x4</p>  <p>Back Cushion</p>
<p><b>(F)</b>x2</p>  <p>Seat Middle Frame</p>	<p><b>(G)</b>x4</p>  <p>Front Middle/Stool Frame</p>	<p><b>(H)</b>x4</p>  <p>Side Middle Frame</p>	<p><b>(I)</b>x2</p>  <p>Back Middle Frame</p>	<p><b>(J)</b>x1</p>  <p>Seat Stool Frame</p>
<p><b>(K)</b>x2</p>  <p>Right Corner Frame</p>	<p><b>(L)</b>x1</p>  <p>Table Cover Frame</p>	<p><b>(M)</b>x1</p>  <p>Front Table Frame</p>	<p><b>(N)</b>x1</p>  <p>Behind Table Frame</p>	<p><b>(O)</b>x1</p>  <p>Right Side Table Frame</p>
<p><b>(P)</b>x1</p>  <p>Bottom Table Frame</p>	<p><b>(Q)</b>x2</p>  <p>Small Back Cushion</p>	<p><b>(R)</b>x1</p>  <p>Left Side Table Frame</p>		

# Hardware :

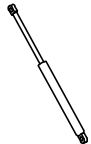
<p><b>①</b> x 4 pcs Extra 1 pcs</p>  <p>Bolt M6 x 15mm</p>	<p><b>②</b> x 54 pcs Extra 4 pcs</p>  <p>Bolt M6 x 30mm</p>	<p><b>③</b> x 12 pcs Extra 2 pcs</p>  <p>Bolt M6 x 40mm</p>	<p><b>④</b> x 79 pcs Extra 4 pcs</p>  <p>Flat Washer M6 x 1mm</p>	<p><b>⑤</b> x 2 pcs</p>  <p>Allen Key</p>
<p><b>⑥</b> x 1 pc</p>  <p>Key</p>	<p><b>⑦</b> x 1 pc Extra 1 pc</p>  <p>Nut M6</p>	<p><b>⑧</b> x 1 pc Extra 1 pc</p>  <p>Washer M6 x 5mm</p>	<p><b>⑨</b> x 1 pc Extra 1 pc</p>  <p>Washer M6 x 10mm</p>	<p><b>⑩</b> x 1 pc</p>  <p>Gaslift</p>

## STEP 1

(A) x1

(B) x1

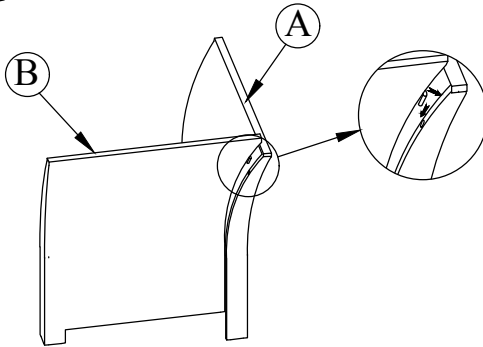

Connect Right Corner Frame (A) & Back Corner Frame (B).

## STEP 2

(2) x2

(4) x2

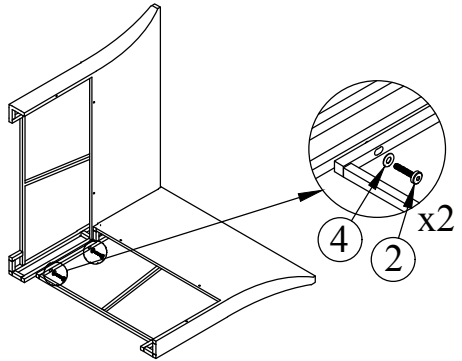

Connect The Part from STEP 1, tighten Bolt (2) and Flat Washer (4) with Allen Key (5).

## STEP 3

(C) x1

(3) x4

(4) x4

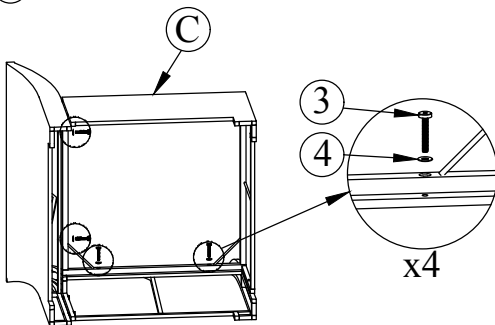

Connect The Part from STEP 2 & Seat Corner Frame (C), tighten Bolt (3) and Flat Washer (4) with Allen Key (5).

## STEP 4

(2) x2

(4) x2

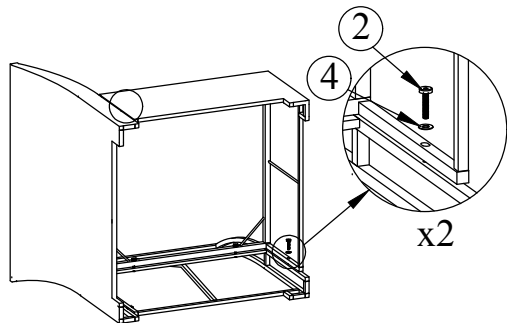
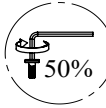

Connect The Part from STEP 3, tighten Bolt (2) and Flat Washer (4) with Allen Key (5).

## STEP 5

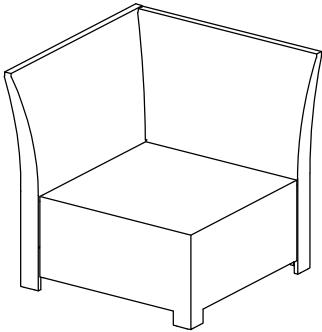

## STEP 6

Ⓓ x1

Ⓔ x1

Ⓚ x1

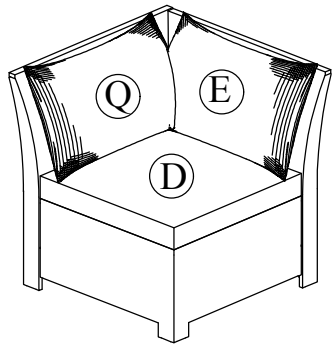

100% tighten

put the Seat Cushion (D) & Back Cushion (E), Small Back Cushion (Q) on to complete the Corner.

## STEP 7

Ⓕ x1

Ⓘ x1

③ x2

④ x2

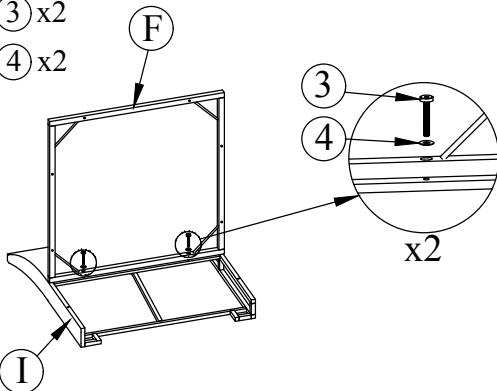
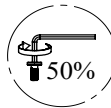

## STEP 8

Ⓗ x1

② x3

④ x3

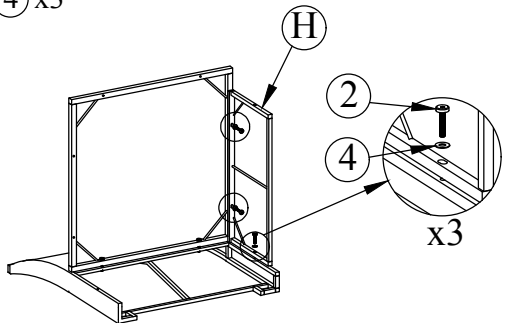

Connect Back Middle Frame (I) & Seat Middle Frame (F), tighten Bolt (3) and Flat Washer (4) with Allen Key (5).

Connect The Part from STEP 7 & Side Middle Frame (H), tighten Bolt (2) and Flat Washer (4) with Allen Key (5).

## STEP 7

(H) x1

(2) x3

(4) x3

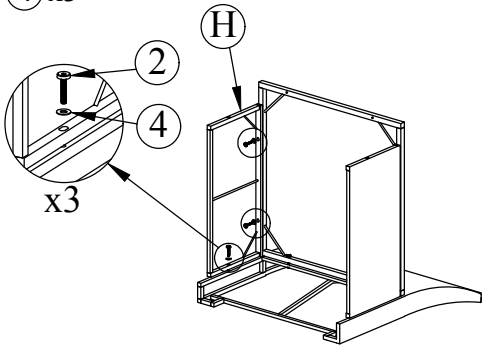
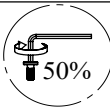

## STEP 8

(G) x1

(2) x4

(4) x4

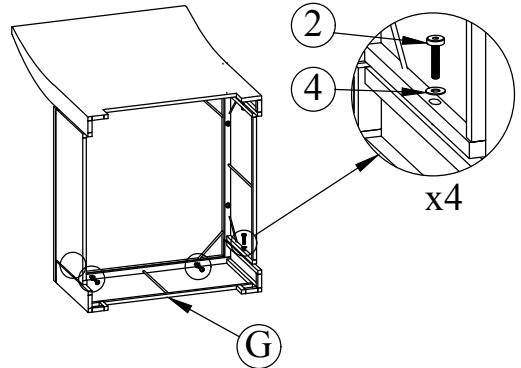

Connect The Part from STEP 8 & Side Middle Frame (H), tighten Bolt (2) and Flat Washer (4) with Allen Key (5).

Connect The Part from STEP 9 & Front Middle/Stool Frame (G), tighten Bolt (2) and Flat Washer (4) with Allen Key (5).

## STEP 9

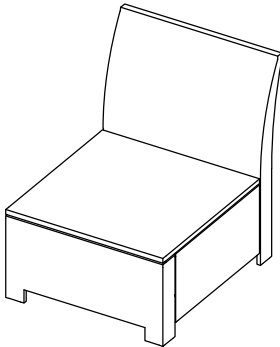

## STEP 10

(D) x1

(E) x1

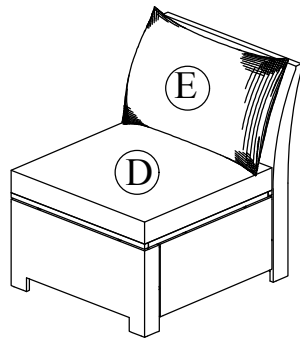

100% tighten.

put the Seat Cushion (D) & Back Cushion (E) on to complete the Middle Chair.

## STEP 11

- Ⓒ x2
- Ⓙ x1
- ② x4
- ④ x4

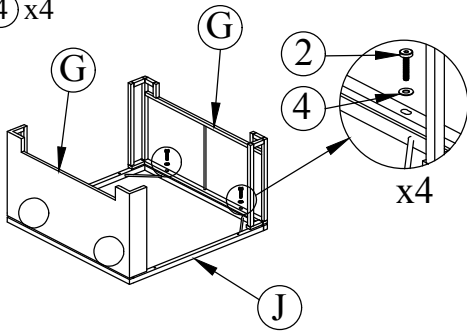

## STEP 12

- Ⓚ x2
- ② x8
- ④ x8

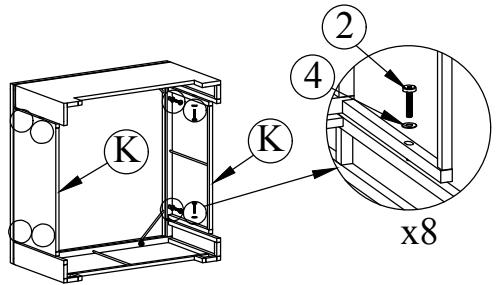

Connect Seat Stool Frame (J) & Front Middle/Stool Frame (G), tighten Bolt (2) and Flat Washer (4) with Allen Key (5).

Connect The Part from STEP 11 & Side Stool Frame (K), tighten Bolt (2) and Flat Washer (4) with Allen Key (5)

## STEP 13

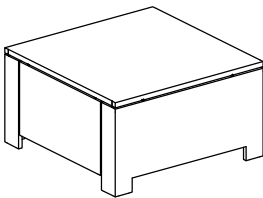

100% tighten.

## STEP 14

- Ⓓ x1

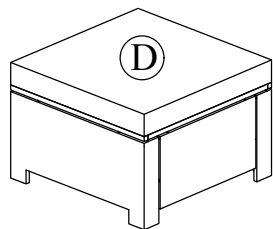

put the Seat Cushion (D) on to complete the Stool.



## STEP 15

(M) x1

(O) x1

(R) x1

(2) x4

(4) x4

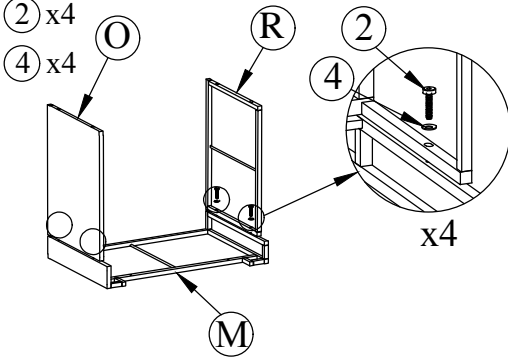

## STEP 16

(N) x1

(2) x4

(4) x4

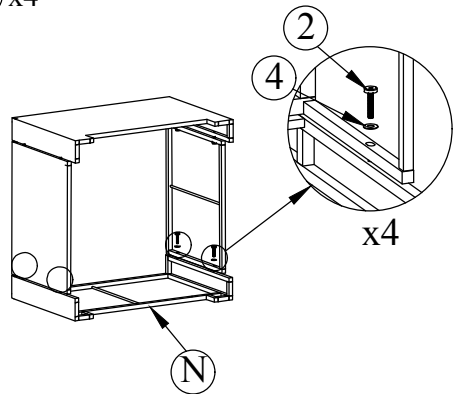

Connect Front Table Frame (M) & Right Side Table Frame (O), Left Side Table Frame (R), tighten Bolt (2) and Flat Washer (4) with Allen Key (5)

Connect The Part from STEP 15 & Behind Table Frame (N), tighten Bolt (2) and Flat Washer (4) with Allen Key (5).

## STEP 17

(P) x1

(2) x4

(4) x4

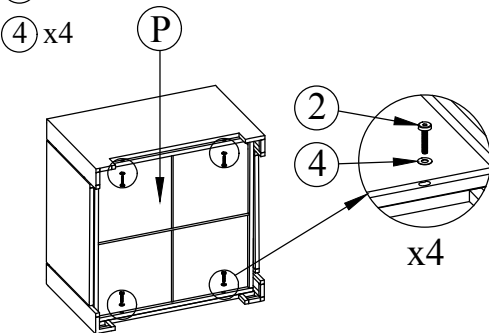

## STEP 18

(L) x1

(1) x4

(4) x4

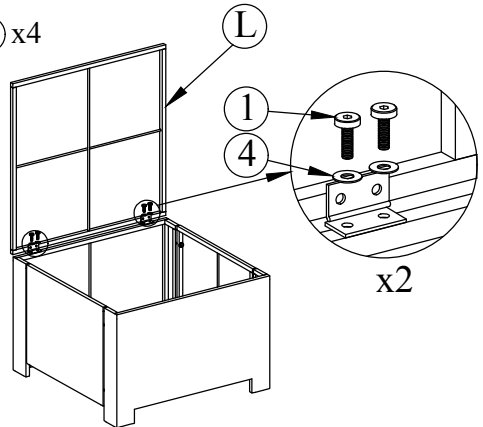

Connect The Part from STEP 16 & Bottom Table Frame (P), tighten Bolt (2) and Flat Washer (4) with Allen Key (5).

Connect The Part from STEP 17 & Table Cover Frame (L), tighten Bolt (1) and Flat Washer (4) with Allen Key (5).

## STEP 19

- ② x2
- ④ x2
- ⑦ x1
- ⑧ x1
- ⑨ x1
- ⑩ x1

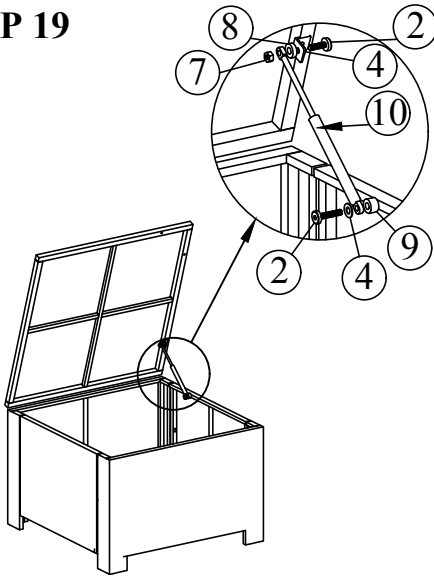

## STEP 20

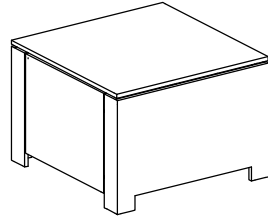

Connect The Part from STEP 18 & Gaslift (10), tighten Bolt (2), Flat Washer (4), Washer (8), (9) and Nut (7) with Allen Key (5), Key (6). 100% tighten to complete the Table.

## STEP 21

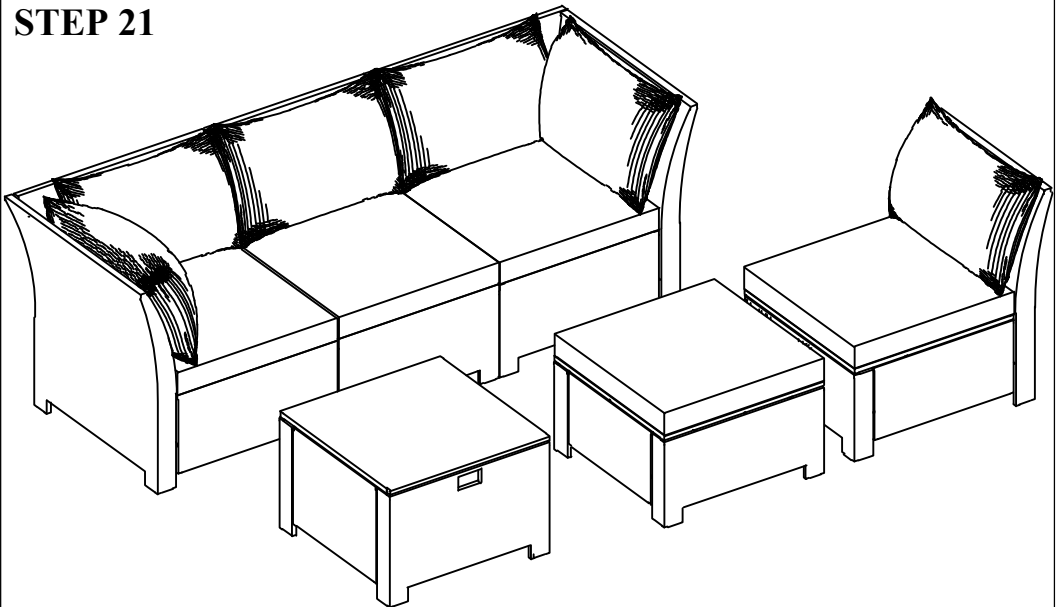

Finish