

# ASSEMBLY INSTRUCTION

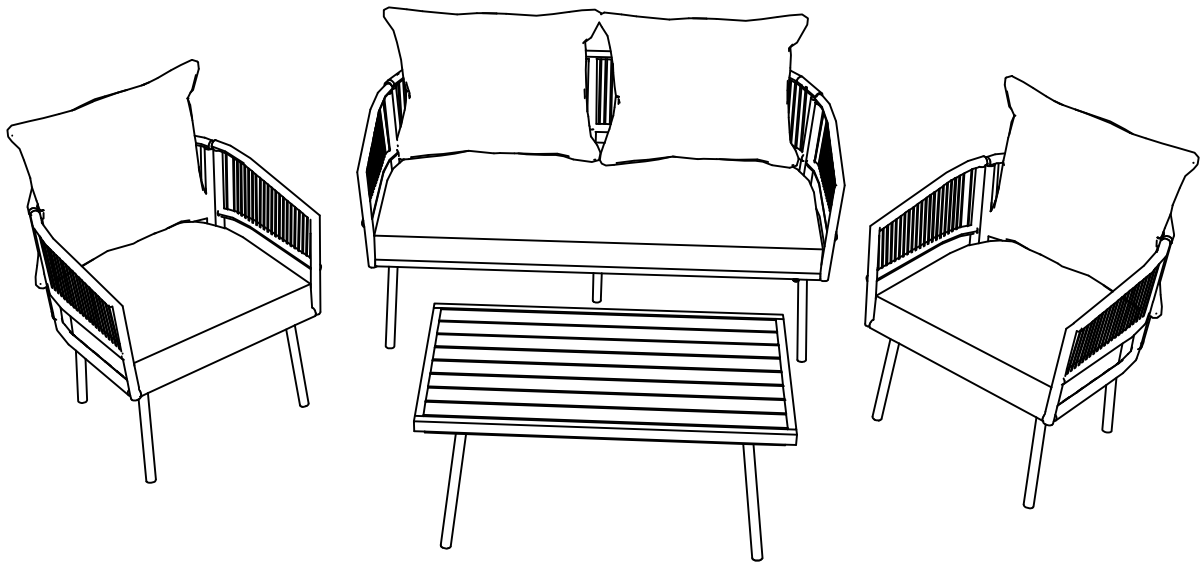

**WF317135**

**WF317136**



**Notice:**

1. 50% Tighten before fixing all screws, Allen wrench is recommended instead of an electric drill.
2. Place the item on a flat ground to adjust and make sure it remains stable.
3. Tighten up all screws with tools gradually.
4. If the screws are not aligned with holes during assembly, please loosen all the other screws to 50% and continue the assembly process.
5. If the item is not stable, please loosen all the screws, adjust it on a flat ground and tighten up all screws again.
6. Note : If one or some screws are fully tightened during assembly, chances are the others will not be aligned with holes. In addition, all the holes are designed to be relatively larger to provide more space for the adjustment of the screws.

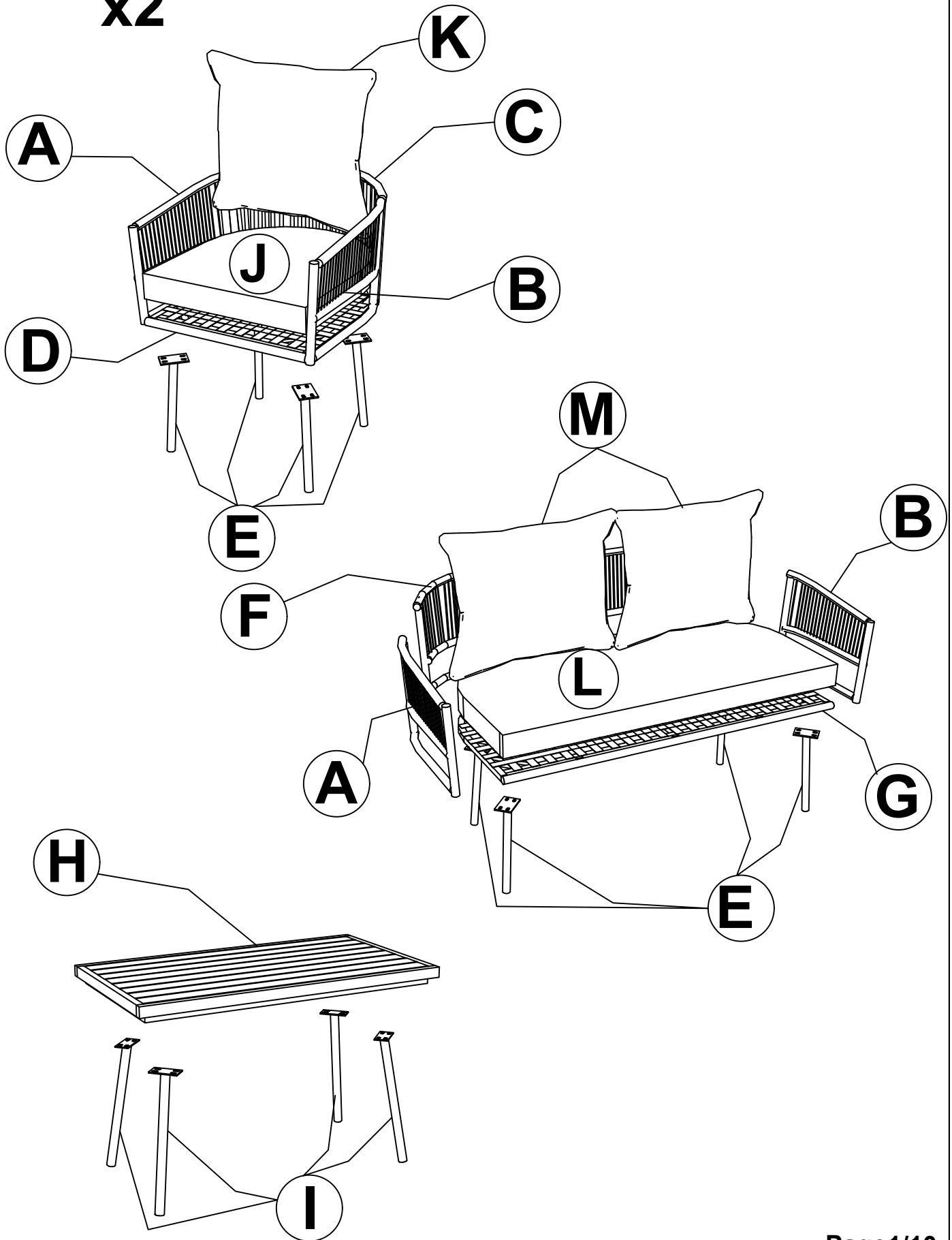

x2

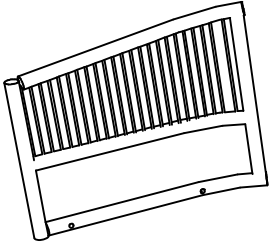
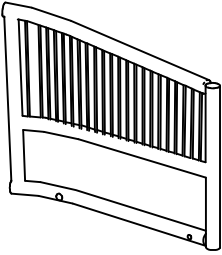
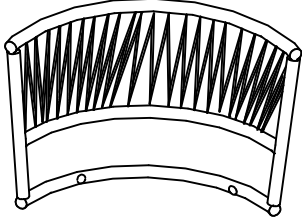
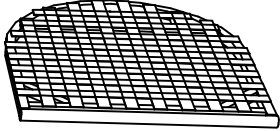
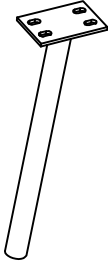
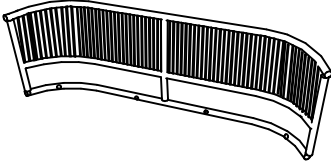
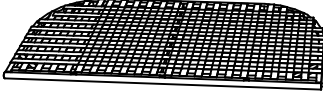
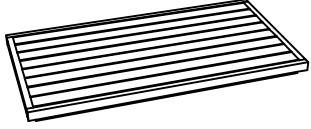
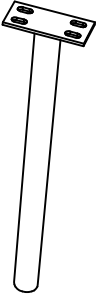
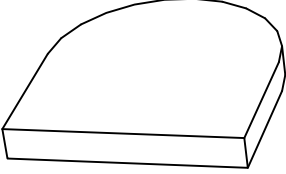

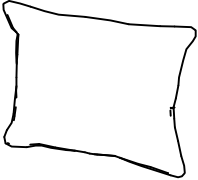
# PART LIST

 <p><b>Ax3</b></p>	 <p><b>Bx3</b></p>	 <p><b>Cx2</b></p>	 <p><b>Dx2</b></p>
 <p><b>Ex12</b></p>	 <p><b>Fx1</b></p>	 <p><b>Gx1</b></p>	 <p><b>Hx1</b></p>
 <p><b>Ix4</b></p>	 <p><b>Jx2</b></p>	 <p><b>Kx2</b></p>	 <p><b>Lx1</b></p>
 <p><b>Mx2</b></p>			

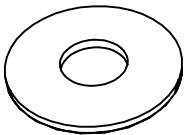
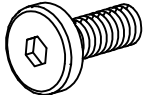
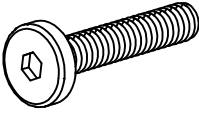
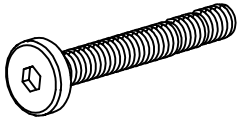
# HARDWARE LIST

 <p><b>1- Washer: 96 pcs</b> Extra : 2 pcs</p>	 <p><b>2- Bolt 6x15: 64 pcs</b> Extra : 2 pcs</p>	 <p><b>3- Bolt 6x40: 20 pcs</b> Extra : 2 pcs</p>	 <p><b>4- Bolt 6x50: 12 pcs</b> Extra : 2 pcs</p>	 <p><b>5- Allen key: 2 pcs</b></p>
---	--	--	---	---

# CARTON CONTENT :

## WF317135 :

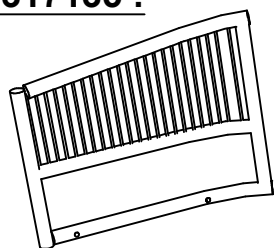

**Ax2**

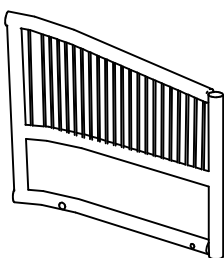

**Bx2**

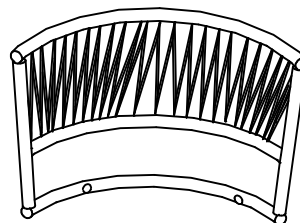

**Cx2**

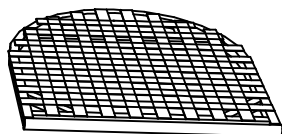

**Dx2**

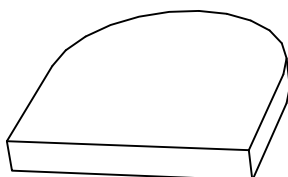

**Jx2**

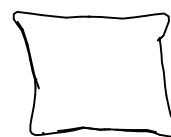

**Kx2**

## WF317136 :

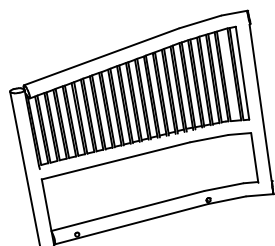

**Ax1**

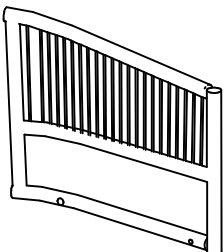

**Bx1**

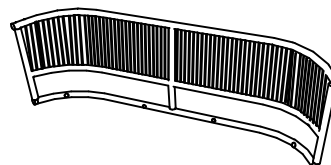

**Fx1**

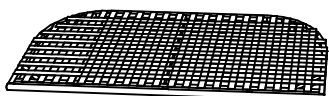

**Gx1**



**Ex12**

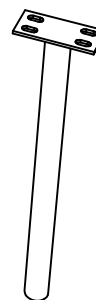

**Ix4**

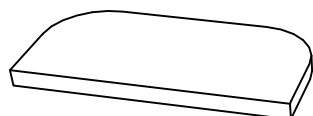

**Lx1**

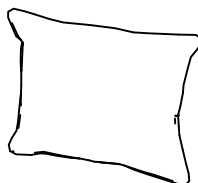

**Mx2**

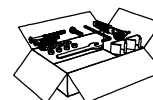

**Hardware**

# Step 1



50%

x2

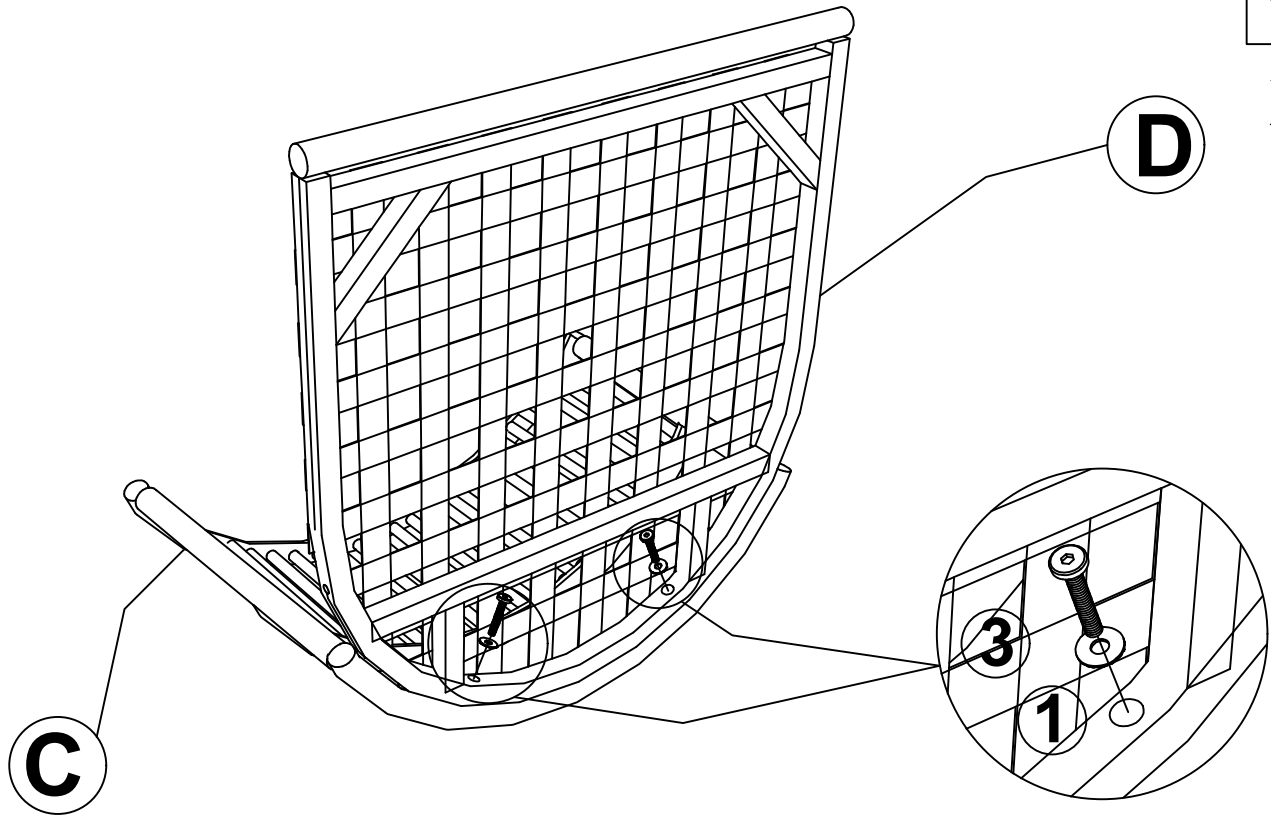

Cx1 Dx1 ①x2 ③x2

# Step 2



50%

x2

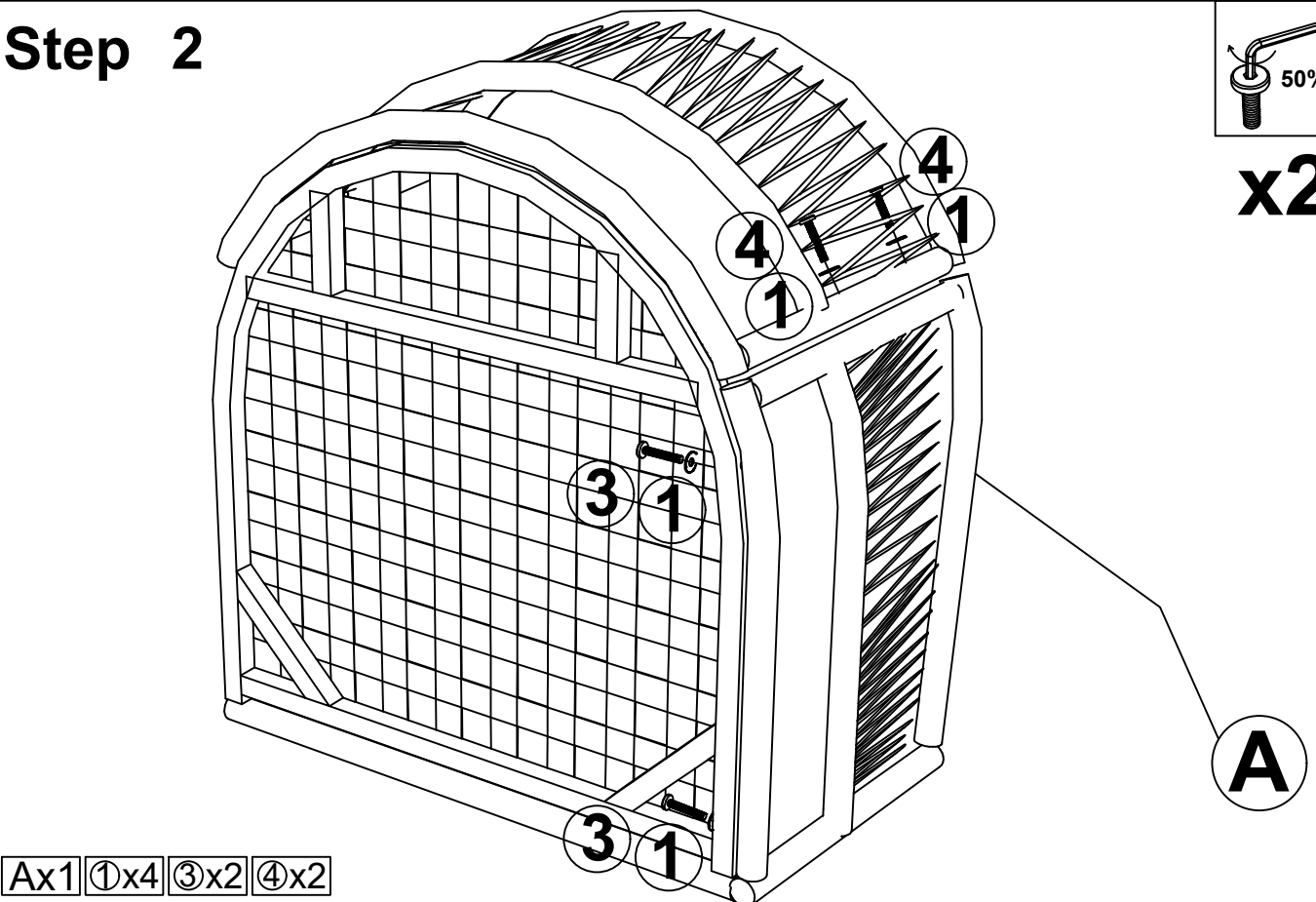

Ax1 ①x4 ③x2 ④x2

# Step 3



x2

B

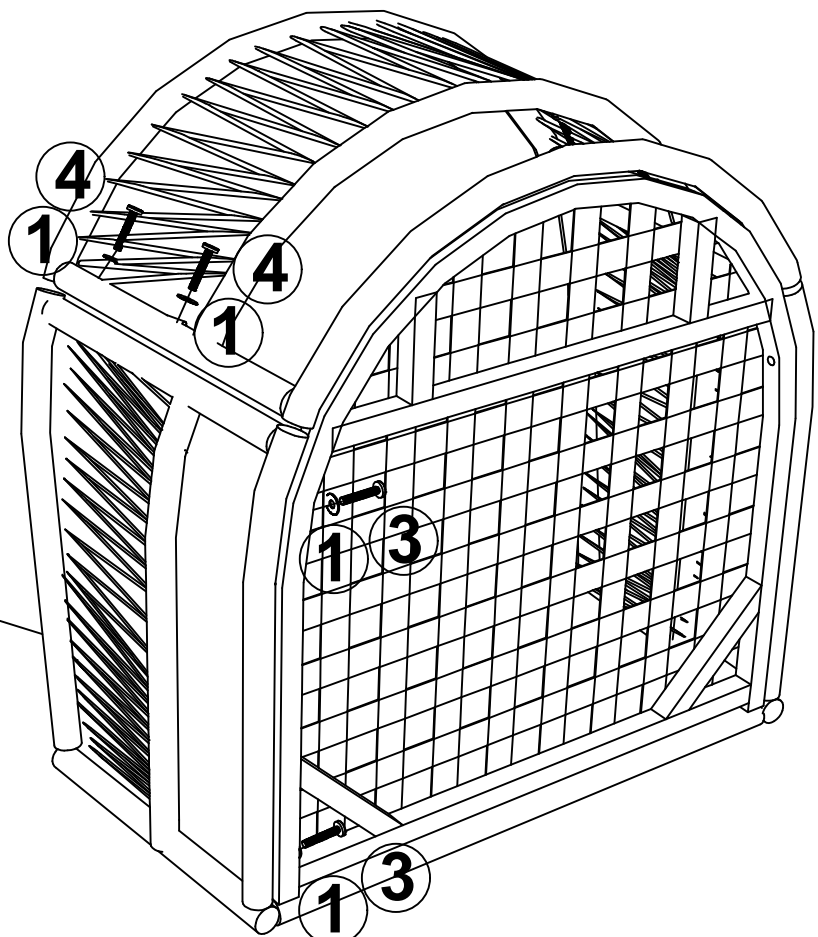

Bx1 ①x4 ③x2 ④x2

# Step 4



x2

E

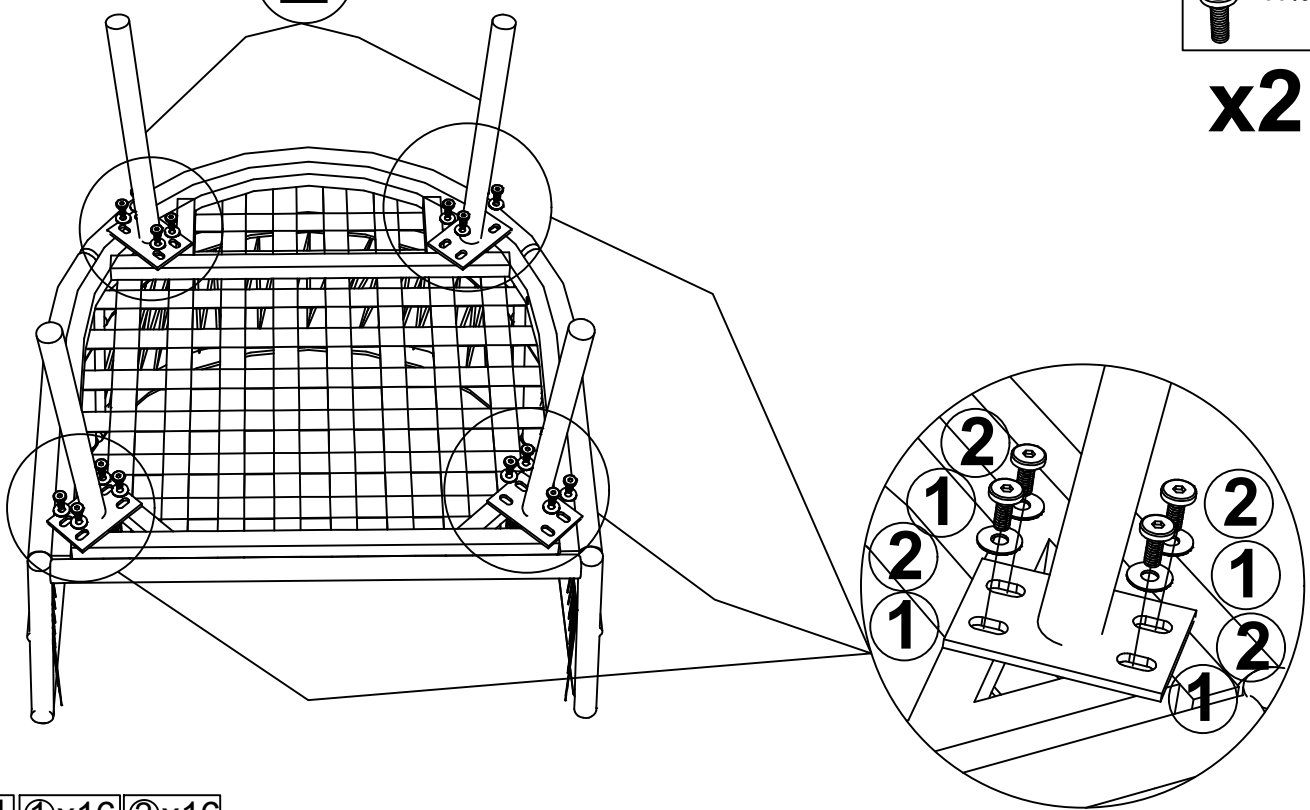

Ex4 ①x16 ②x16

# Step 5



x2

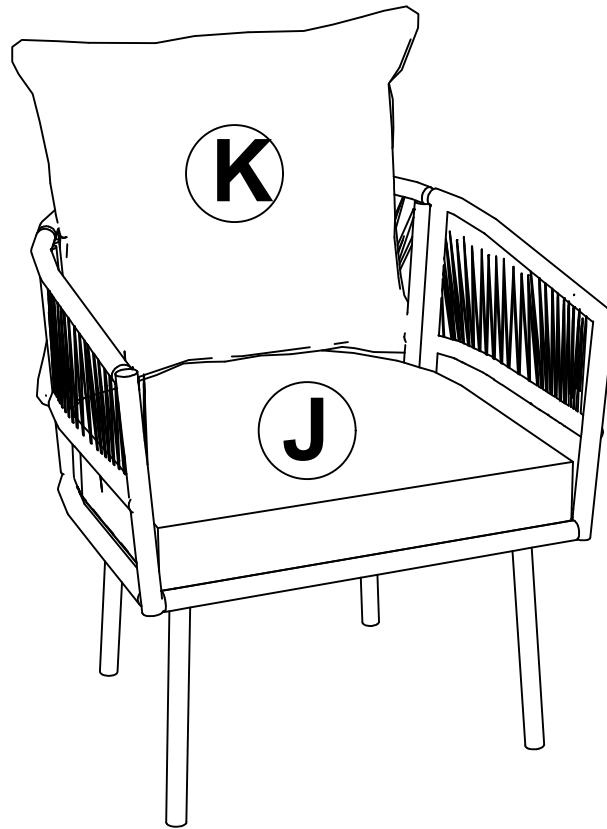

Jx1 Kx1

# Step 6



G

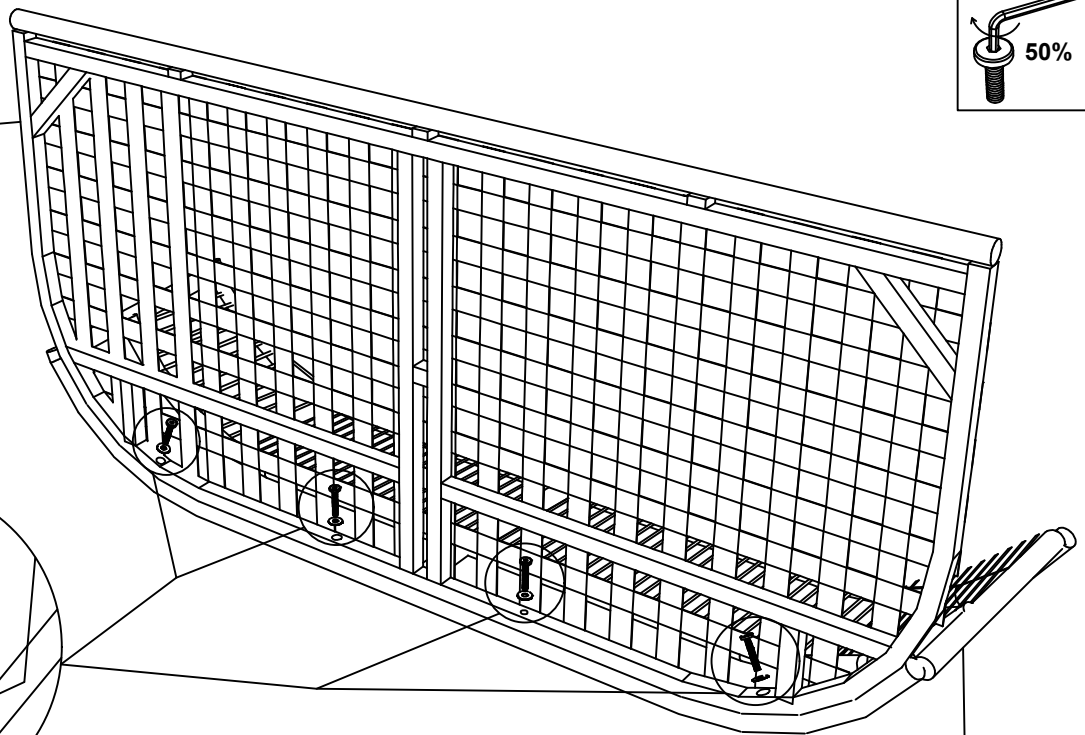
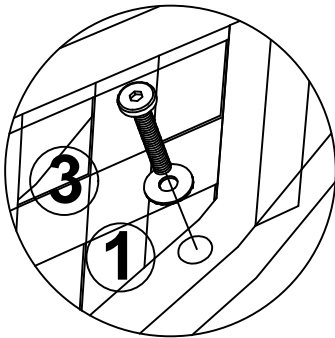

F

Gx1 Fx1 ①x4 ③x4

# Step 7

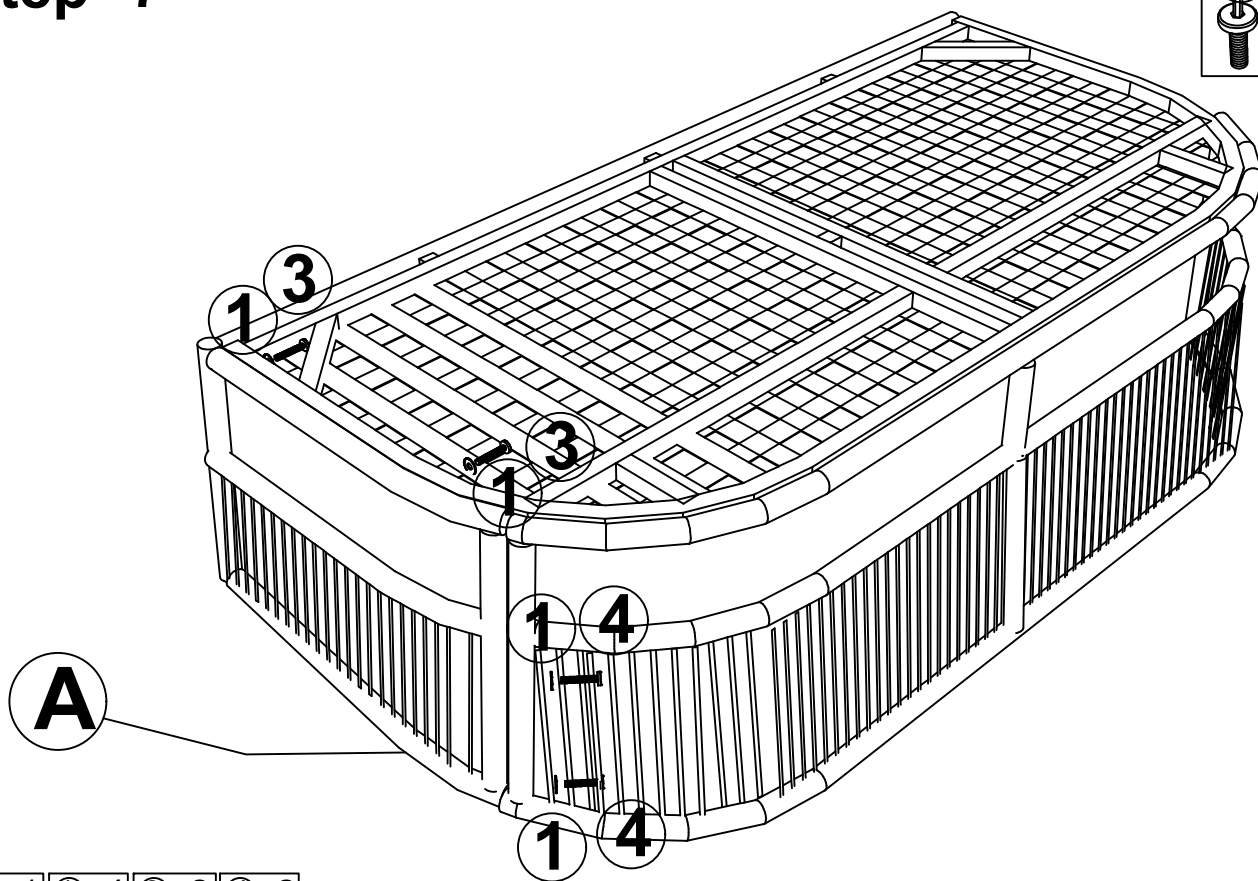
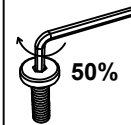

Ax1 ①x4 ③x2 ④x2

# Step 8

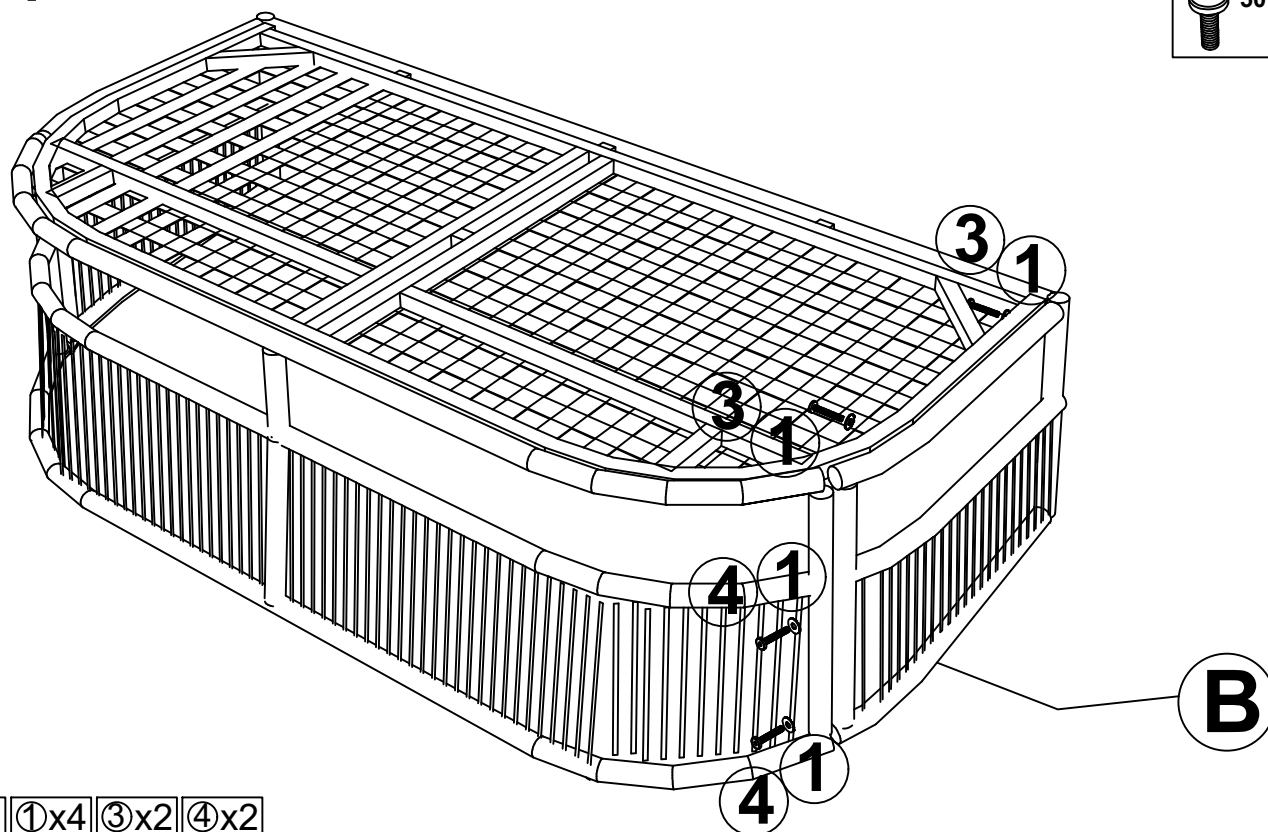
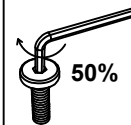

Bx1 ①x4 ③x2 ④x2



# Step 9

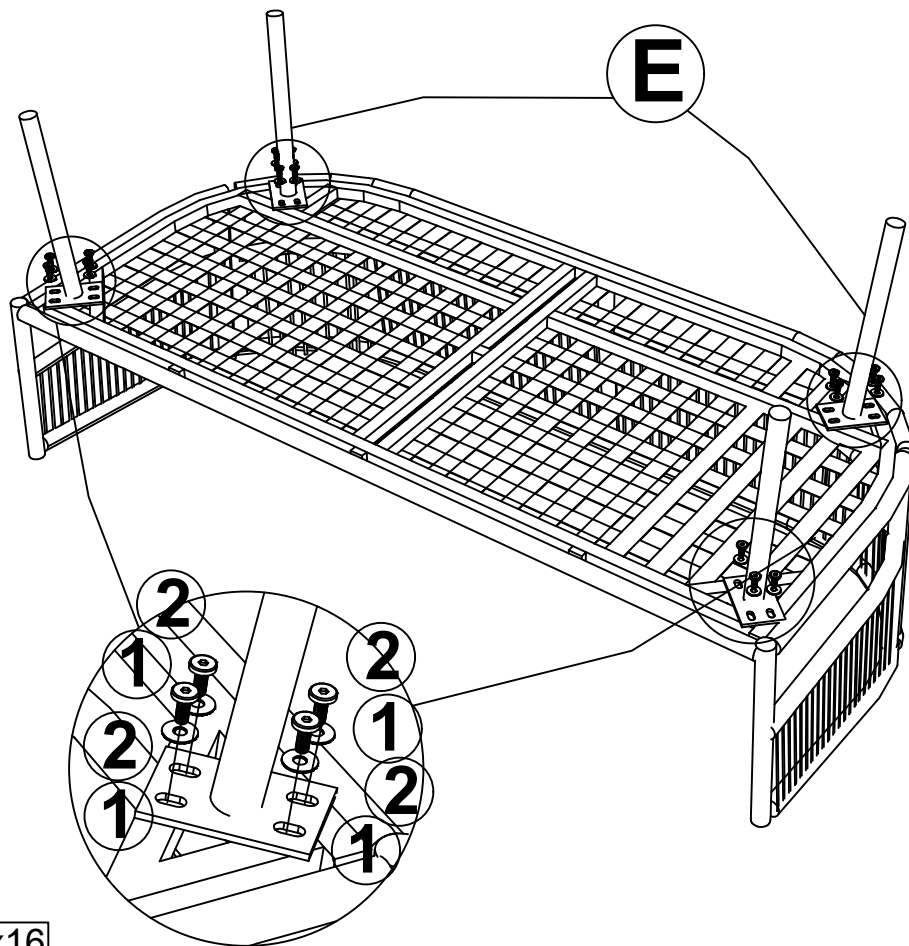

Ex4 ①x16 ②x16

# Step 10

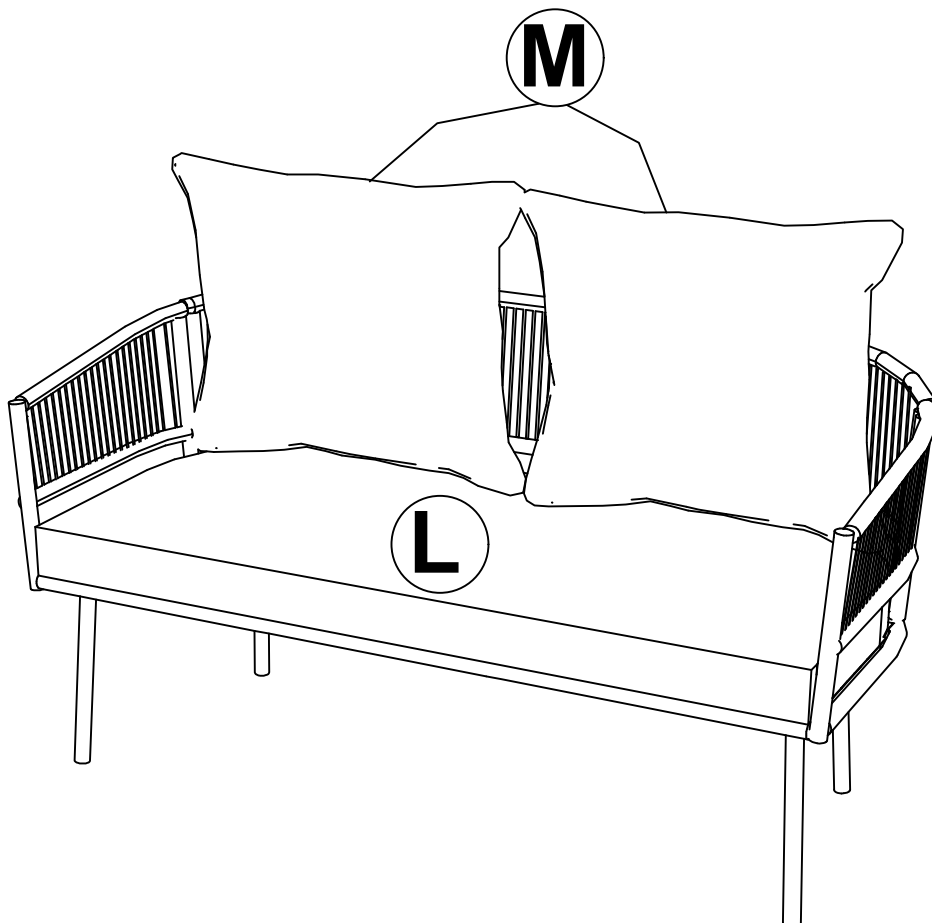

Lx1 Mx2

# Step 11

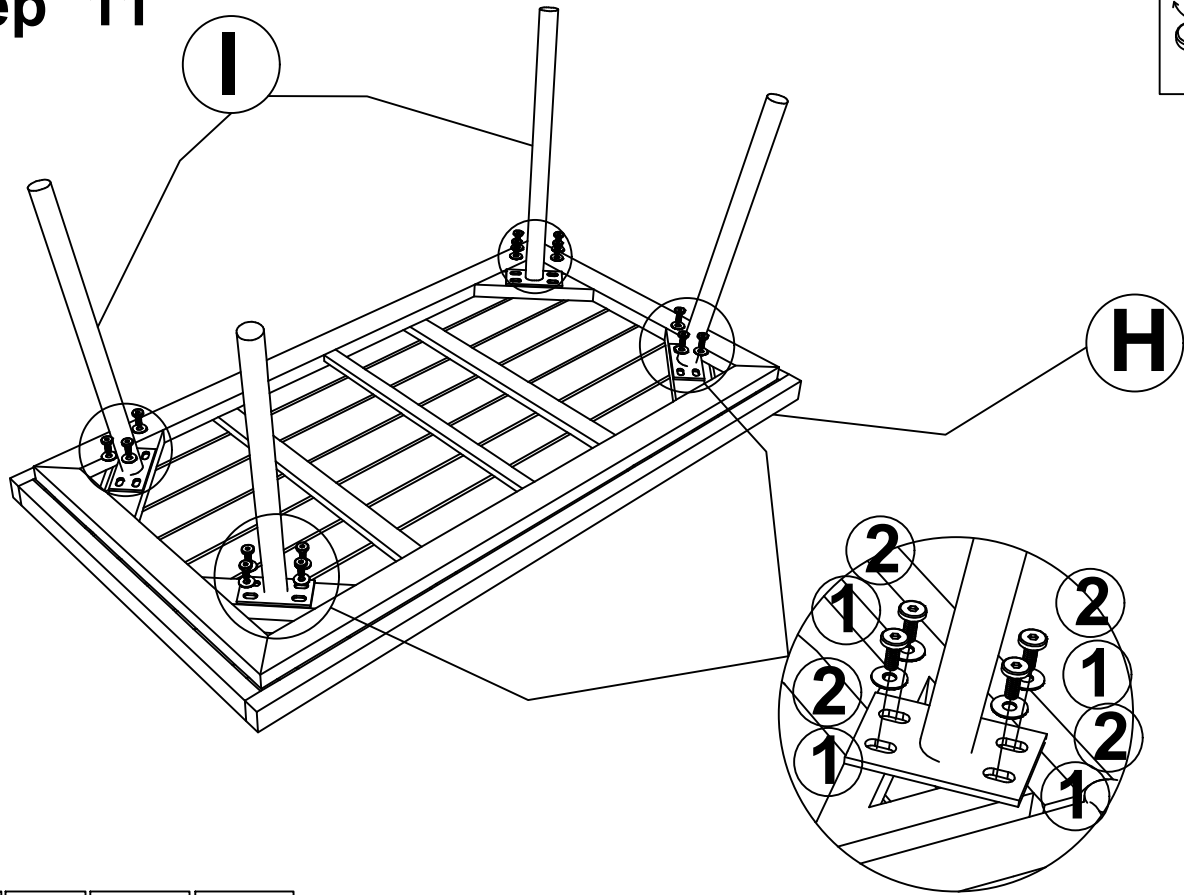

Hx1 | I x4 | ①x16 | ②x16

# Step 12

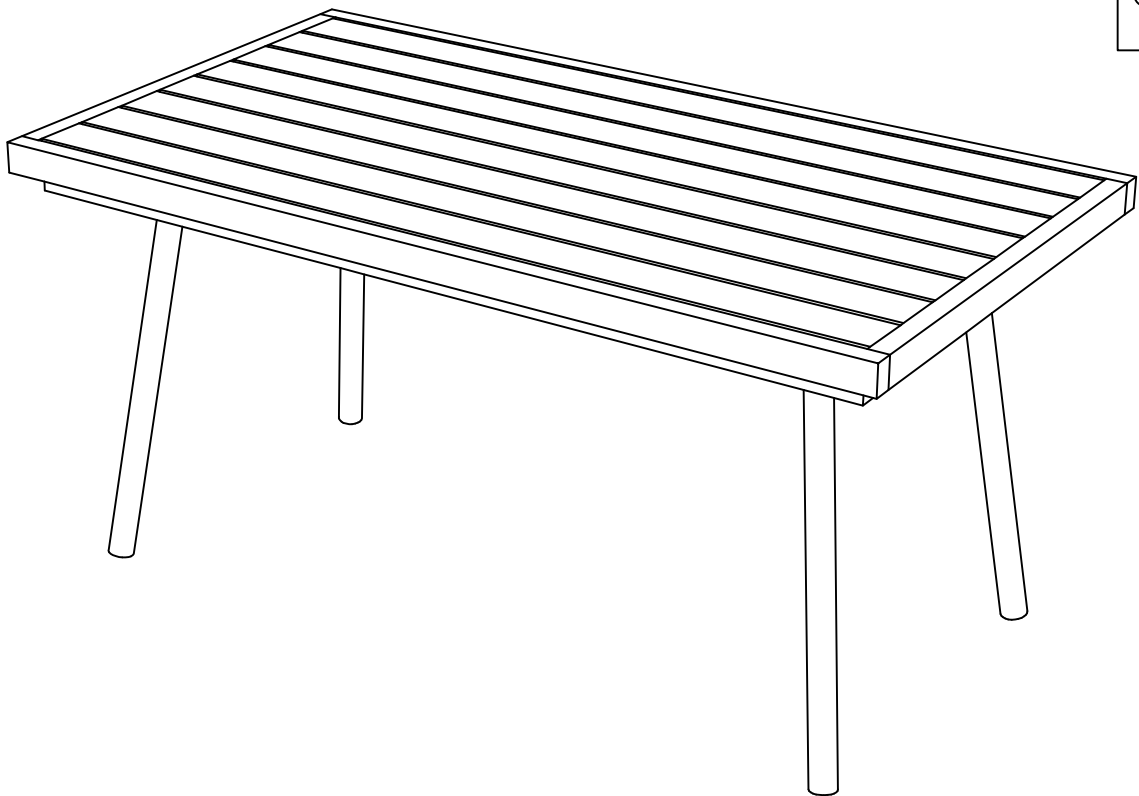

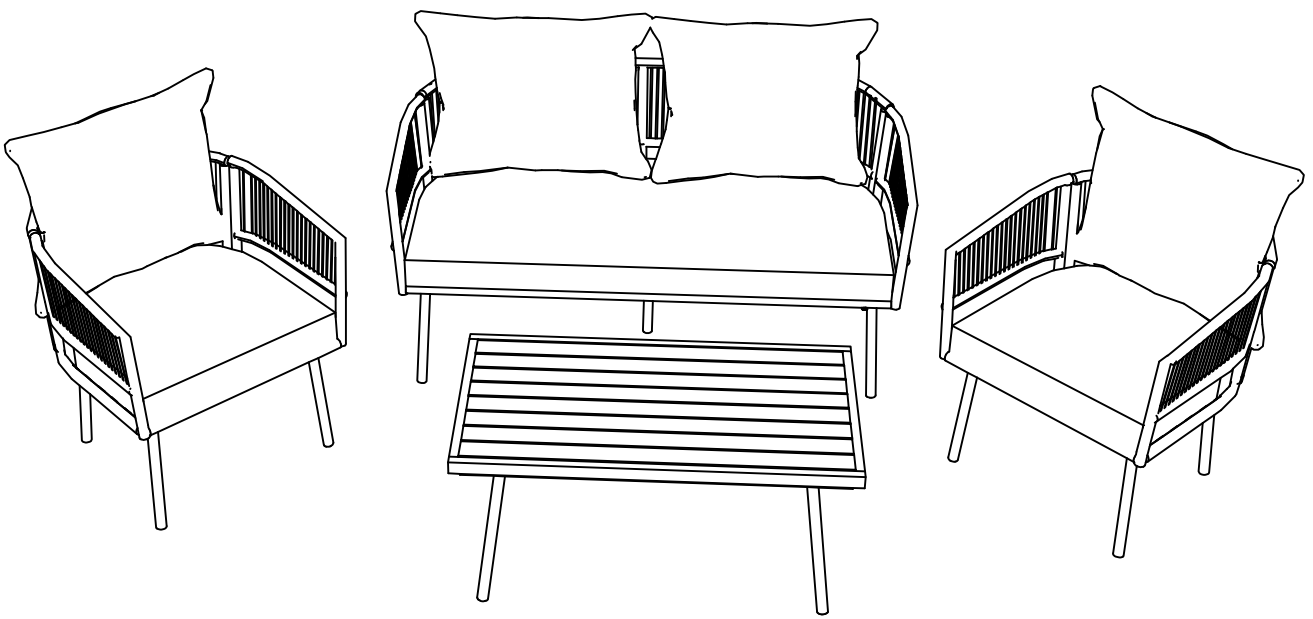

**Finish**