

Climber & Slide

USER MANUAL

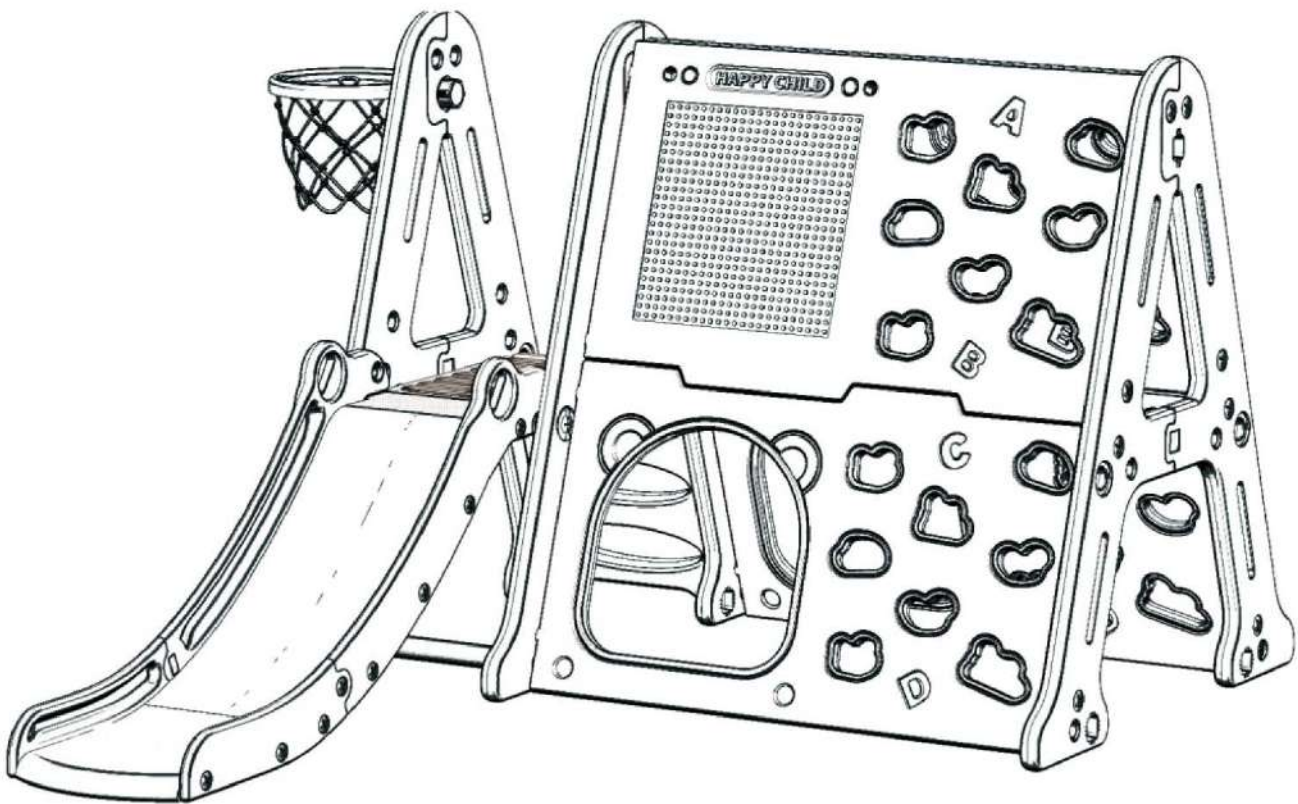

READ AND SAVE THIS INSTRUCTION FOR FUTURE USE

PART LIST

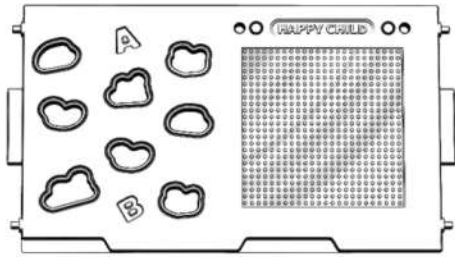

Upper Climber x 2

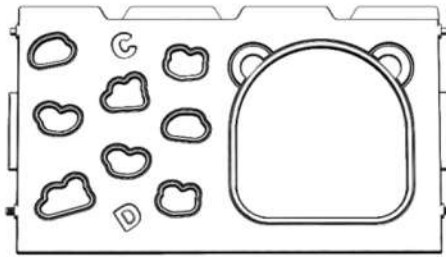

Lower Climber x 2

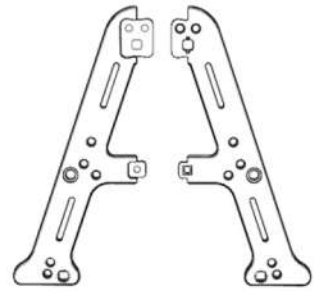

A-Frame Side Panel x 3

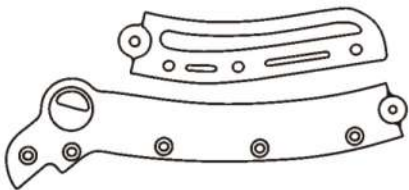

Slide Handrail x 2

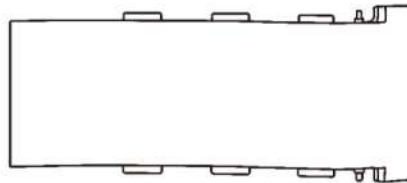

Slide x 1

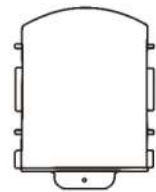

buffer Board x 1

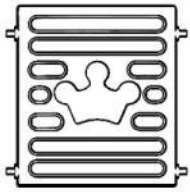

Platform x 1

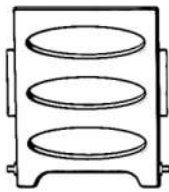

Stair x 1



Basketball Ring x 1

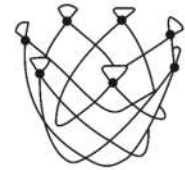

Basketball Net x 1



Connect Bar x 1

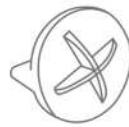

Plastic Screwdriver x 1



Basketball x 1



Metal Screw A x 1



Screw B x 2



Screw C x 16



Screw D x 1



Screw E x 26



Square Screw F x 3



Screw G x 2

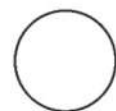

Non-Slip Pad x 3

ASSEMBLY

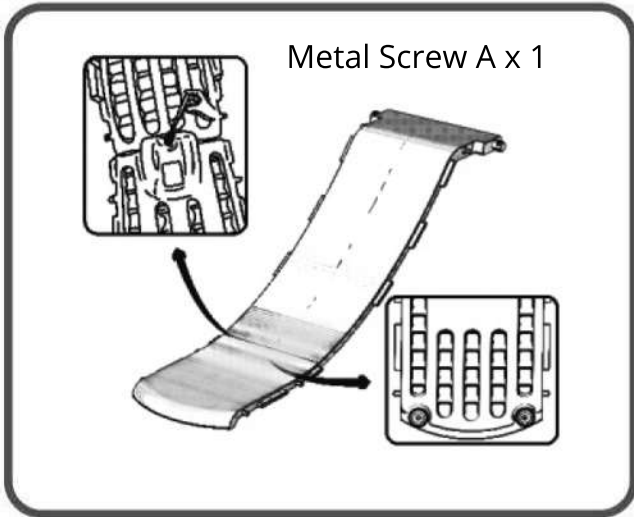

Step1

Connect the Slide and Buffer Board, secure with Screw A on the back. Attach the Non-Slip Pad under the Slide as shown for extra stability.

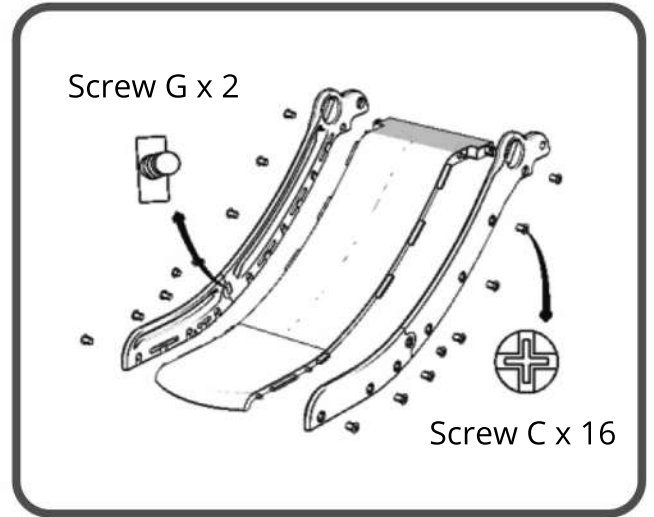

Step2

Connect the Handrails together with Screw G, and then attach the long Handrail to Slide, secure with 8pcs Screw C on each side, 16pcs in total. Tighten with Plastic Screwdriver.

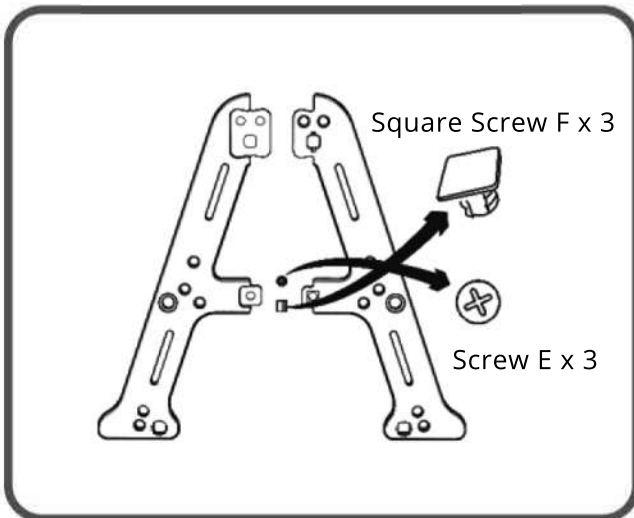

Step3

Connect the A-Frame Side Panel with 1pc Square Screw F and 1pc Screw E on each set. Repeat the same to complete 3 sets in total.

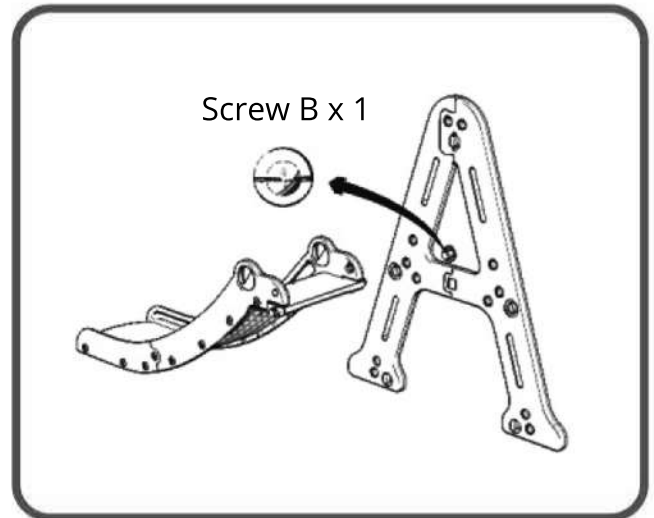

Step4

Attach the Slide section to the A-Frame Side Panel, secure with 1pc Screw B.

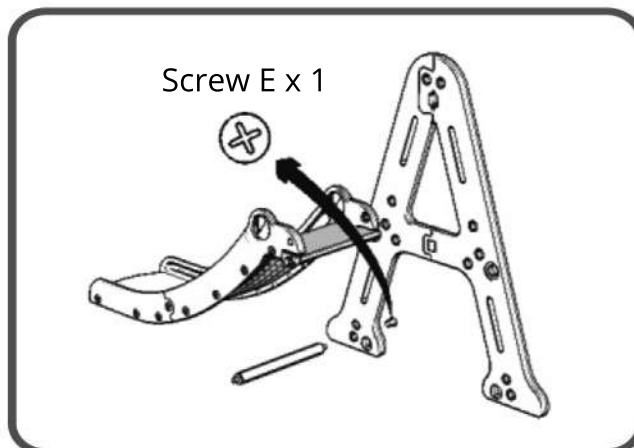

Step5

Insert the Connect Bar into the hole at the bottom of A-Frame, secure with 1pc Screw E.

ASSEMBLY

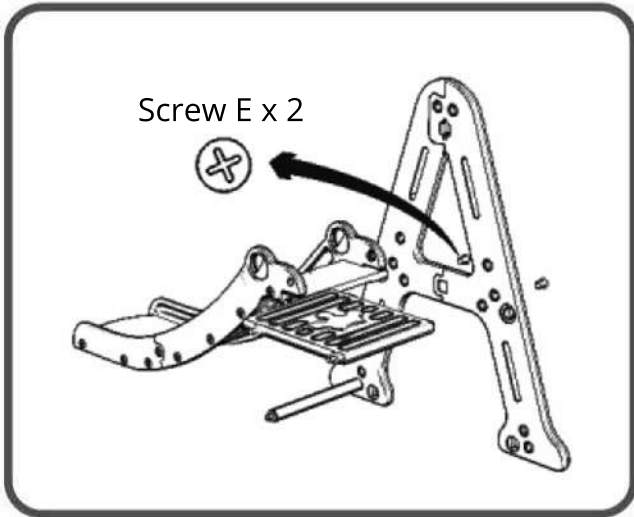

Step6

Install the Platform, secure it to A-Frame with 2pcs Screw E.

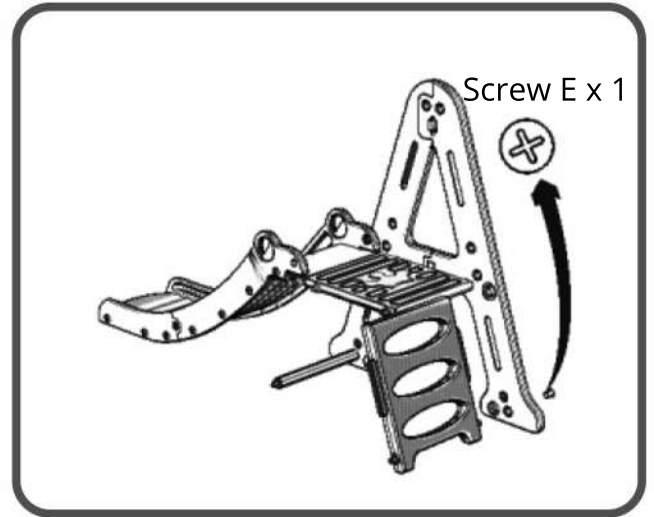

Step7

Connect the stair and A-Frame Side Panel, secure with 1pc Screw E at the bottom.

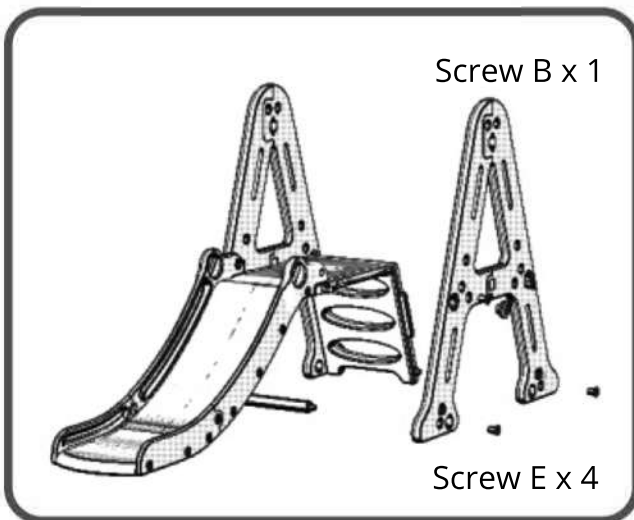

Step8

Attach the second A-Frame to the section assembled, secure the with 4pcs Screw E.

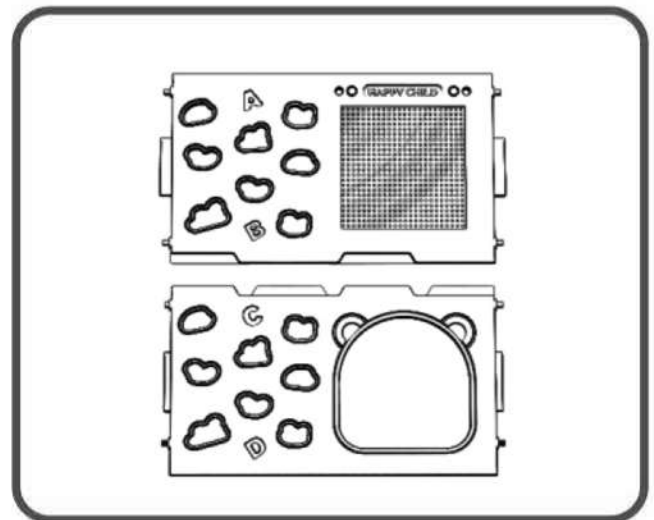

Step9

Combine the Upper Climber and Lower Climber. No screw needed in this step.

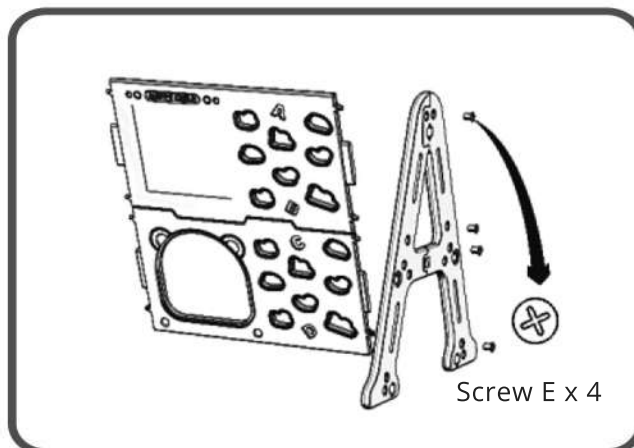

Step10

Connect 1 Climber Panel with the 3rd A-Frame Panel, secure with 4pcs Screw E as shown.

ASSEMBLY

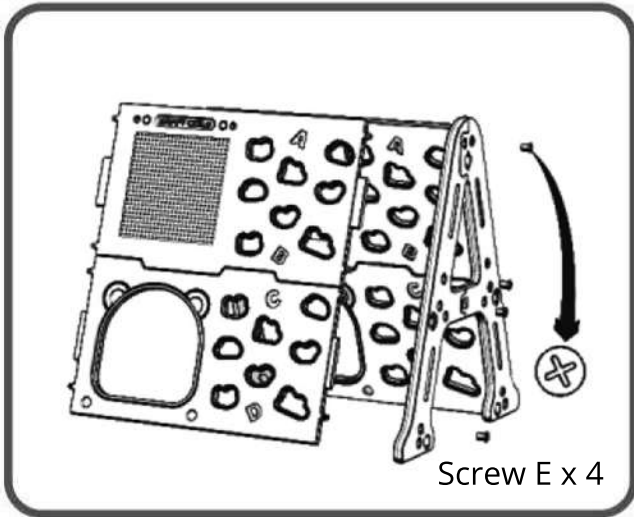

Step11

Repeat the same to attach the other climber to the A-Frame Panel, secure with 4pcs Screw E.

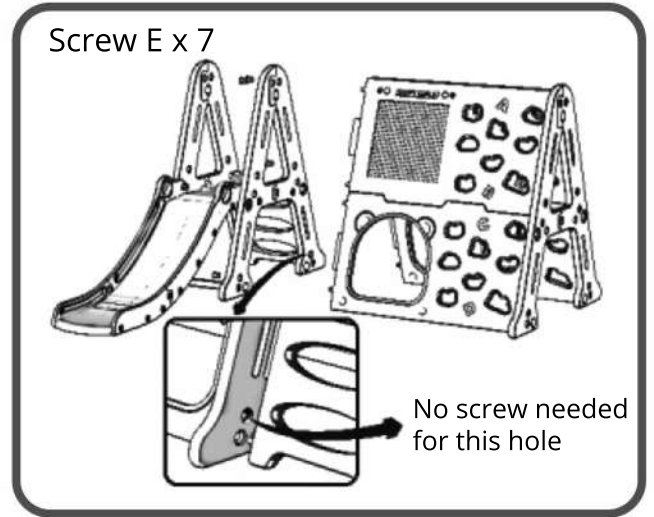

Step12

Connect the Climber section and the A-Frame Side Panel on the Slide section, secure with 7pcs Screw E.

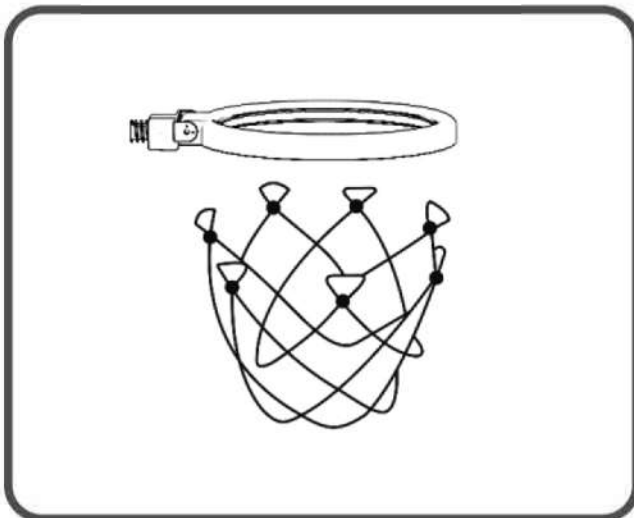

Step13

Attach the Basketball Net to the Ring.

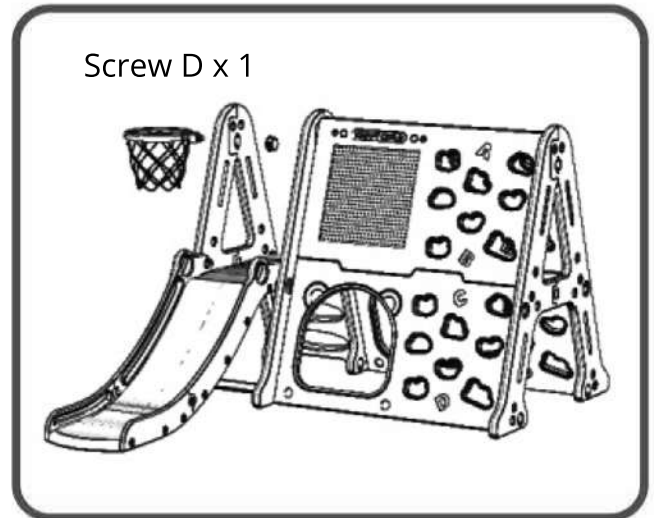

Step14

Install the Basketball Hoop on the A-Frame Side Panel, secure with Screw D.