











Assembly Instructions

CAUTION: You must read this Assembly Instructions before you proceed.

Care & Maintenance

- ⊘  ● Not for commercial use. For residential use only.
- ⊘  ● Do not put hot items directly on furniture surface.
- ⊘  ● Do not clean furniture with harsh cleansers or polish.
- ✓  ● To obtain the longest lifespan of your outdoor products, minimizing exposure to direct sunlight is recommended.
- ⊘  ● Children should not climb or jump on the furniture.
- ⊘  ● Do not write on furniture without a padded barrier to protect the surface.
- ✓  ● To obtain the longest lifespan of your outdoor products, avoid extended and lengthy exposure to rain, snow, and direct sunshine. Whenever possible cover the product and /or place under patio or awnings.
- ⊘  ● Stains may be removed with mild soap solution and damp cloth.
- ✓  ● Keep away from sources of ignition .
- ✓  ● Dust and pick-up spills using a clean, non-colored, lint-free cloth.

Please look under the Seat Panel for hardware pack.

SIDE TABLE

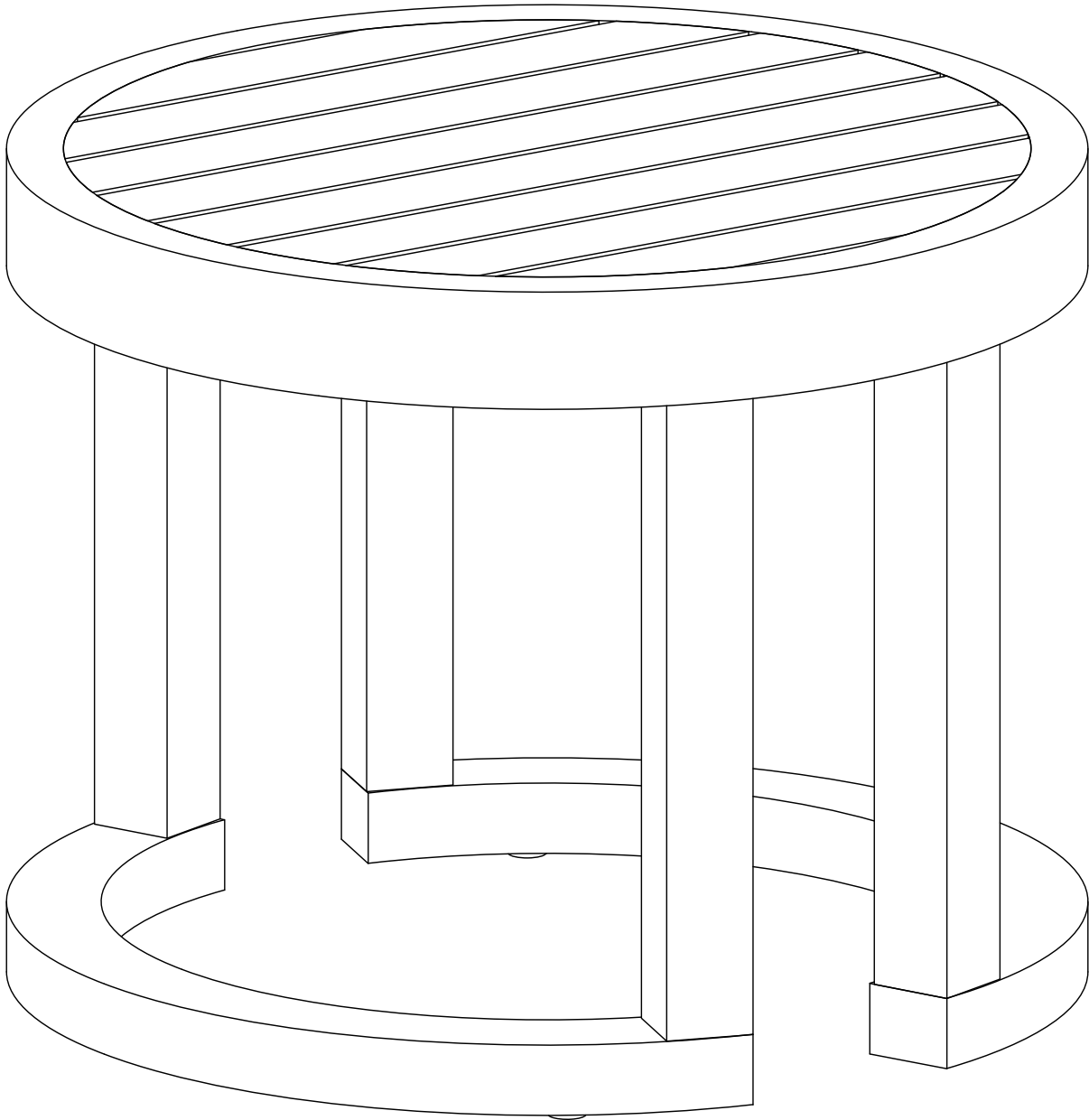



CAUTION : This Table is NOT a TOY.

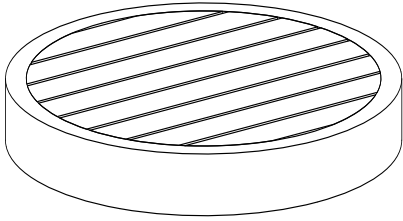
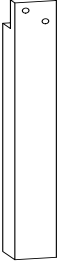

Keep your child / children at bay in the process of assembly.

For turning the Table and to prevent damage to the Table, 02 persons may be needed to execute this action.

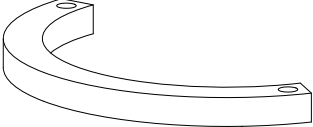
Parts List

Label	Picture	Description	QTY
A		Table Top	1
B		First Leg	2
C		Second Leg	2
D		Support Leg	2

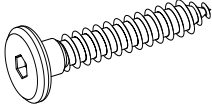
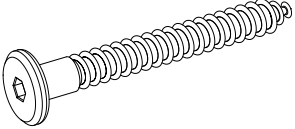
Hardware

Label	Picture	Description	QTY
①		Screws (M6x35x13mm)	9
②		Screws (M7x60x15mm)	5
③		Allen Wrench (K4)	2

Assembly Preparation

Before Beginning Assembly:

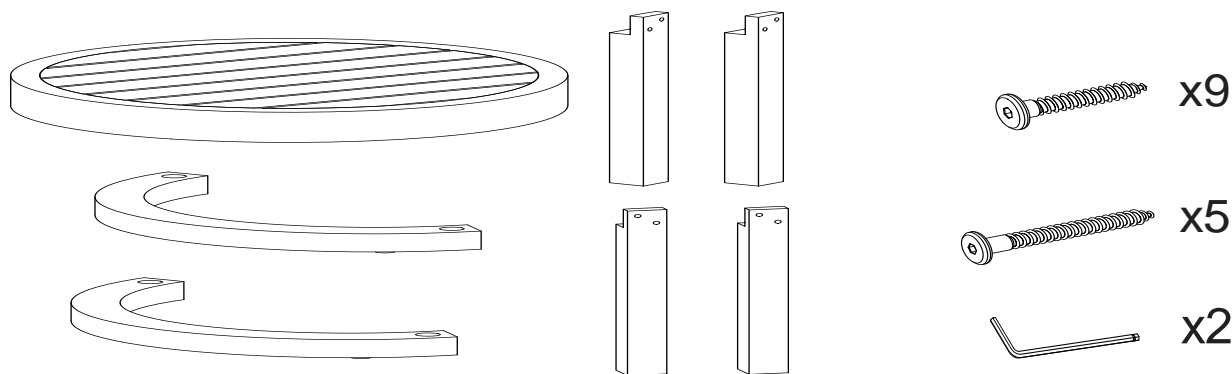

- Read instructions, cover to cover.
- Have 2 adults on hand for assembly.
- Do not assemble on flooring or carpet.
- Assemble on a clean non-marring surface (packing foam).
- Save all packaging until finished.

Assembly steps

Overview

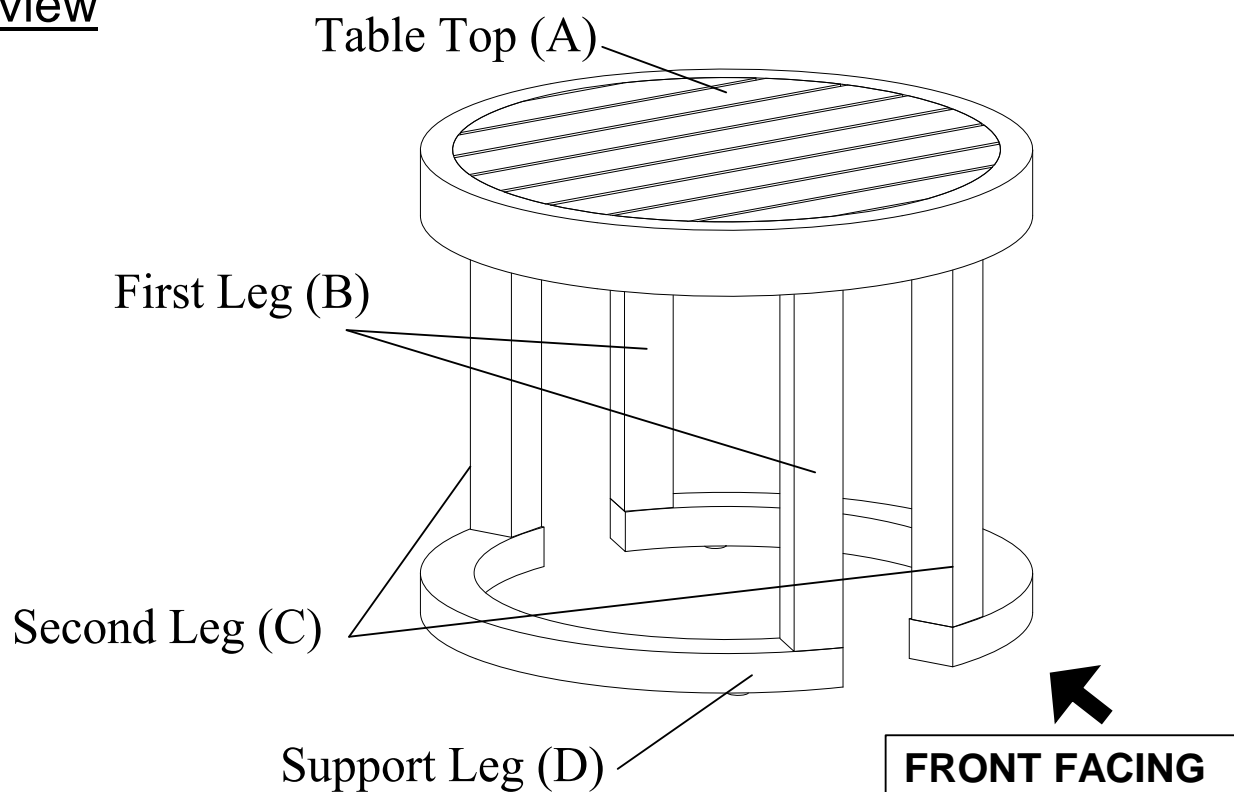

This Table has multiple parts and may require up to 15 minutes to assemble. To give you an overview of the Table parts, the above picture is to help you put the various parts into perspective. Please read through the instructions below to familiarise yourself with the parts and steps before assembly.

Step 1

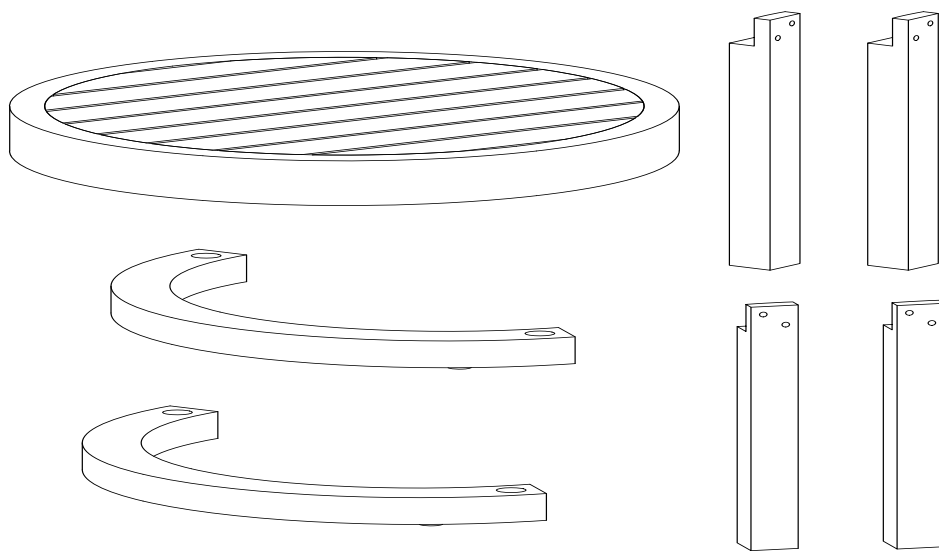

Unpack and place all parts on a clean, non-marring surface.

Step 2

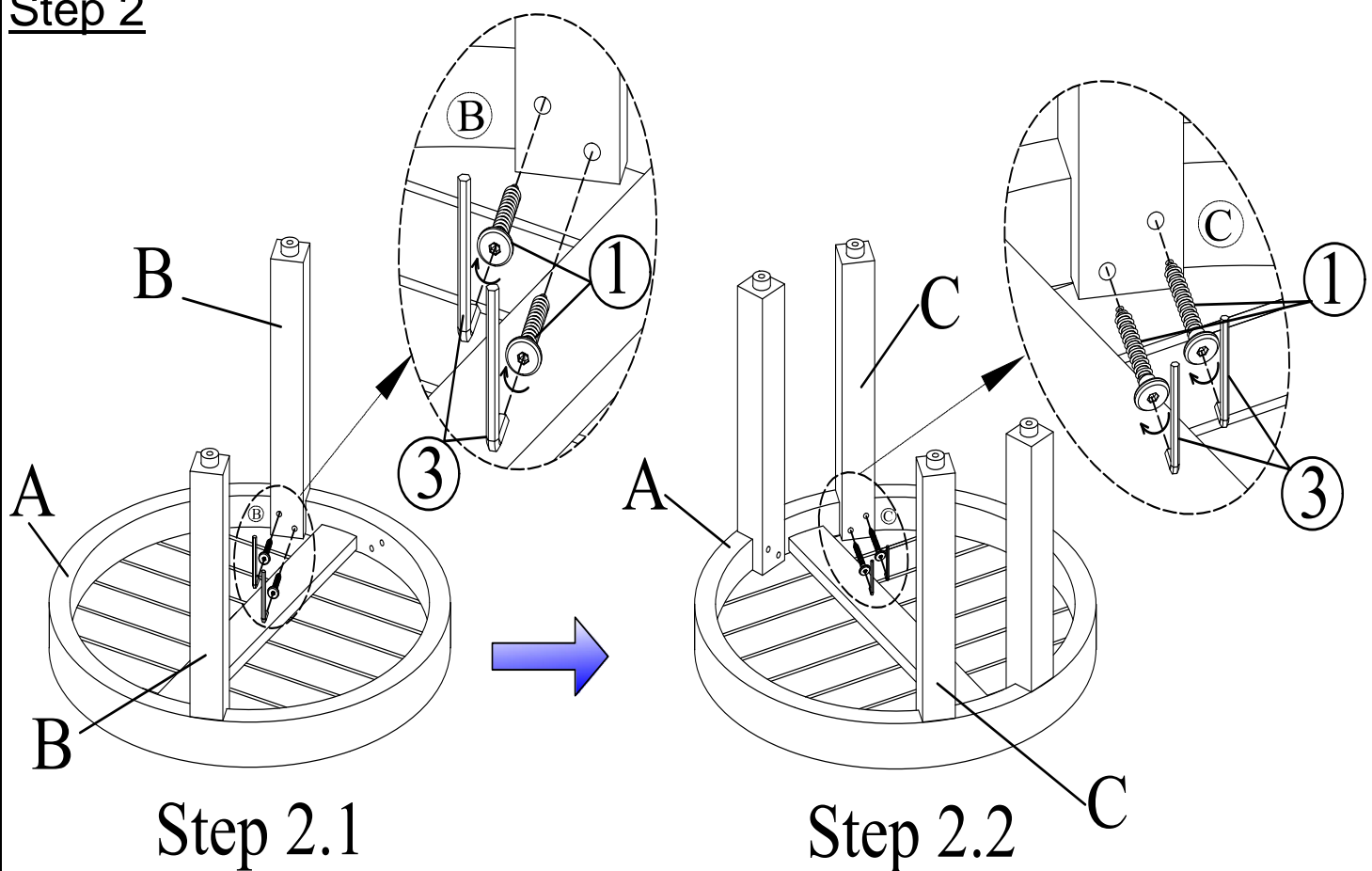

With assistance from your adult partners, carefully place the Table Top (A) facedown on a clean, non-marring surface.

2.1 Attach the First Legs (B) in the position labelled B of the Table Top (A) using Screws (1) and the Allen Wrench (3) as shown above.

2.2 Attach the Second Legs (C) in the position labelled C of the Table Top (A) using Screws (1) and the Allen Wrench (3) as shown above.

DO NOT FULLY TIGHTEN THE SCREWS.

Step 3

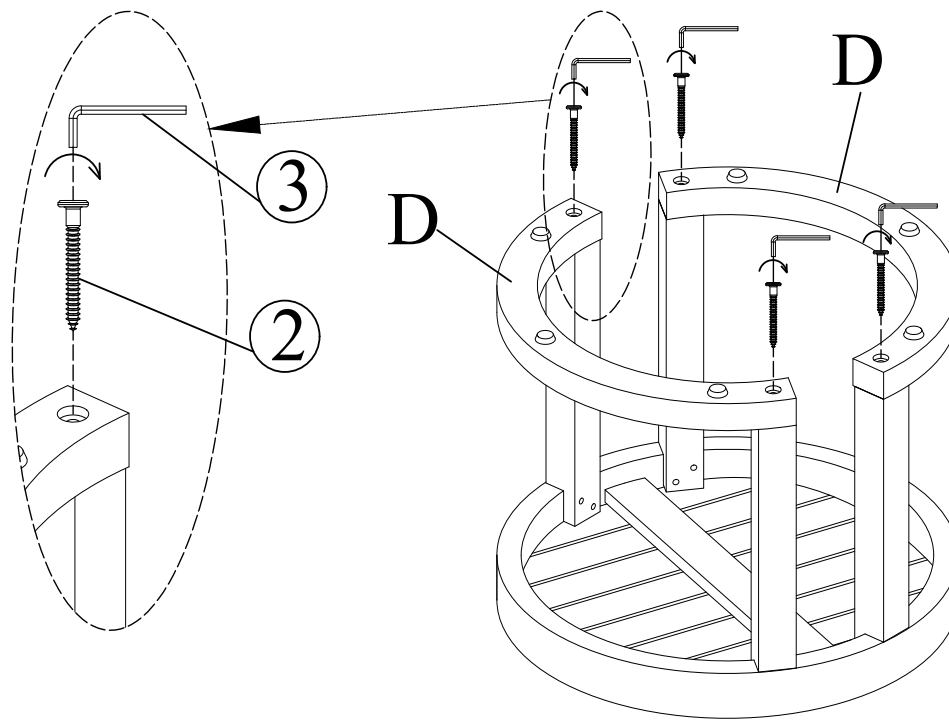

Attach the Support Leg (D) to the assembled parts in step 2 using Screws (②) and the Allen Wrench (③) as shown above.

Repeat the same process with the remain Support Leg (D).

DO NOT FULLY TIGHTEN SCREWS.

Step 4

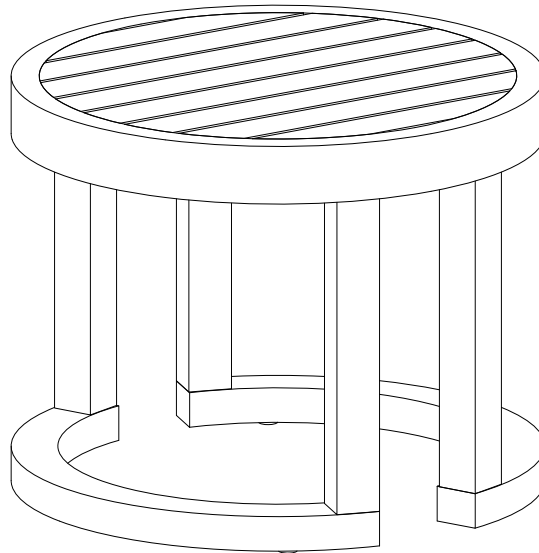

Turn the Table right side up.

EXERT pressure, floorwards, onto the Table.

This pressure will help the Legs and Table Top reach alignment at all joints.

Check for wobbles.

In a sequential manner, gradually tighten all Screws until evenly secured.

Inspect the Table and make sure all parts are adequately connected.











Your Table is ready for use.

This Table can only be used on a flat, level surface.

Assembly Instructions

Caution : You must read this before you proceed

Care & Maintenance

- ⊘  ● Not for commercial use. For residential use only.
- ⊘  ● Prolonged exposure to rain may cause rusting which can stain floors.
- ⊘  ● Do not put hot items directly on furniture surface.
- ⊘  ● Do not clean furniture with harsh cleansers or polish.
- ✓  ● To obtain the longest lifespan of your outdoor products, minimizing exposure to direct sunlight is recommended.
- ⊘  ● Children should not climb or jump on the furniture.
- ⊘  ● Do not write on furniture without a padded barrier to protect the surface.
- ✓  ● To obtain the longest lifespan of your outdoor products, avoid extended and lengthy exposure to rain, snow, and direct sunshine. Whenever possible cover the product and /or place under patio or awnings.
- ⊘  ● Stains may be removed with mild soap solution and damp cloth.
- ✓  ● Keep away from sources of ignition.
- ✓  ● Dust and pick-up spills using a clean, non-colored, lint-free cloth.

Please look in the Seat Panel for hardware packs.

CLUB CHAIR

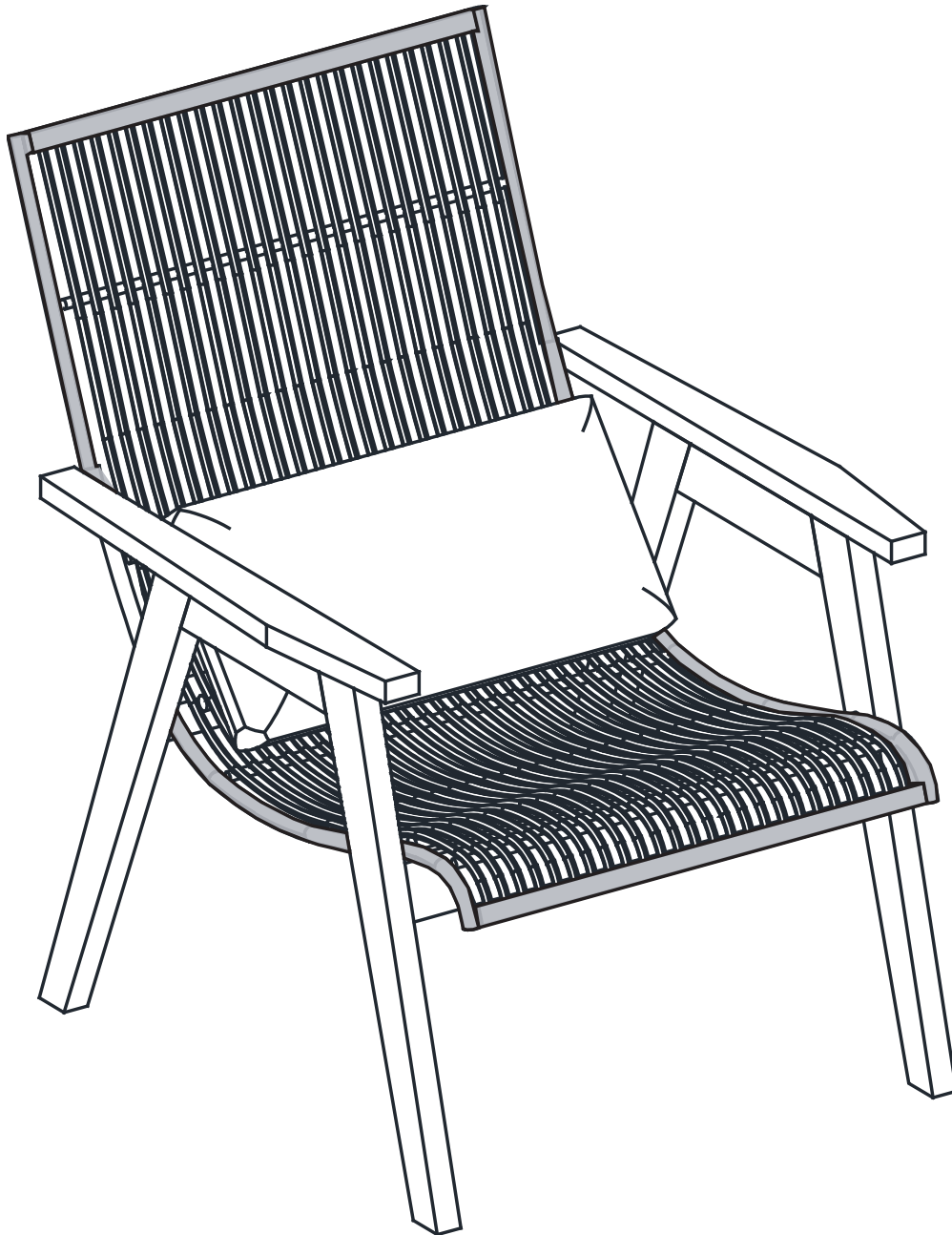



Caution: This Chair is NOT a TOY.





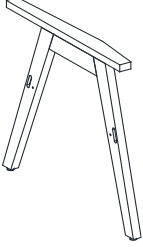
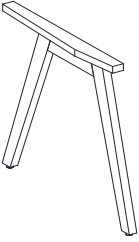
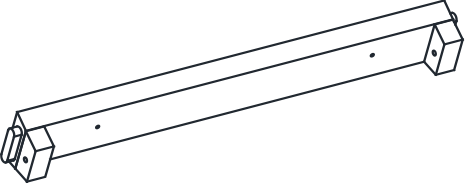
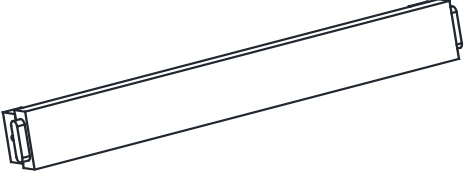

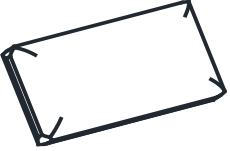
Keep your child/children at bay during the assembly process.

Whenever lifting or moving the Chair and to prevent damage to the Chair, two adults may be needed to execute these actions.

Parts List

Label	Picture	Description	QTY
A		Right Arm Panel	1
B		Left Arm Panel	1
C		Back Support Bar	1
D		Front Support Bar	1
E		Frame Wicker	1
F		Pillow	1

Hardware

Label	Picture	Description	QTY
①		Bolt (M6x40mm)	5
②		Bolt (M6x15mm)	7
③		Screw (M6x20mm)	7
④		Washer(6.5x20x1.5)	13
⑤		L- Bracket	6
⑥		Allen Wrench	2

Assembly Preparation

Before Beginning Assembly:

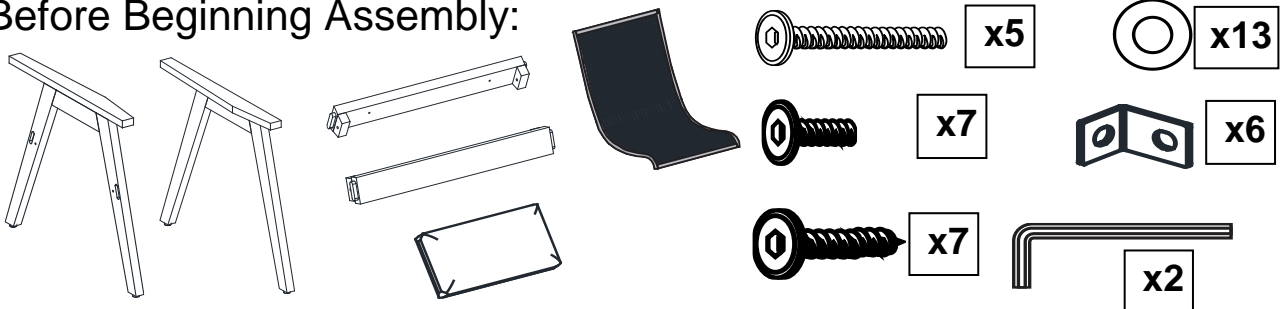

- Read instructions, cover to cover-



- Have 2 adults on hand for assembly-



- Do not assemble on flooring or carpet-



- Assemble on a clean non-marring surface (packing foam)-



- Save all packaging until finished-

Assembly Steps

Overview

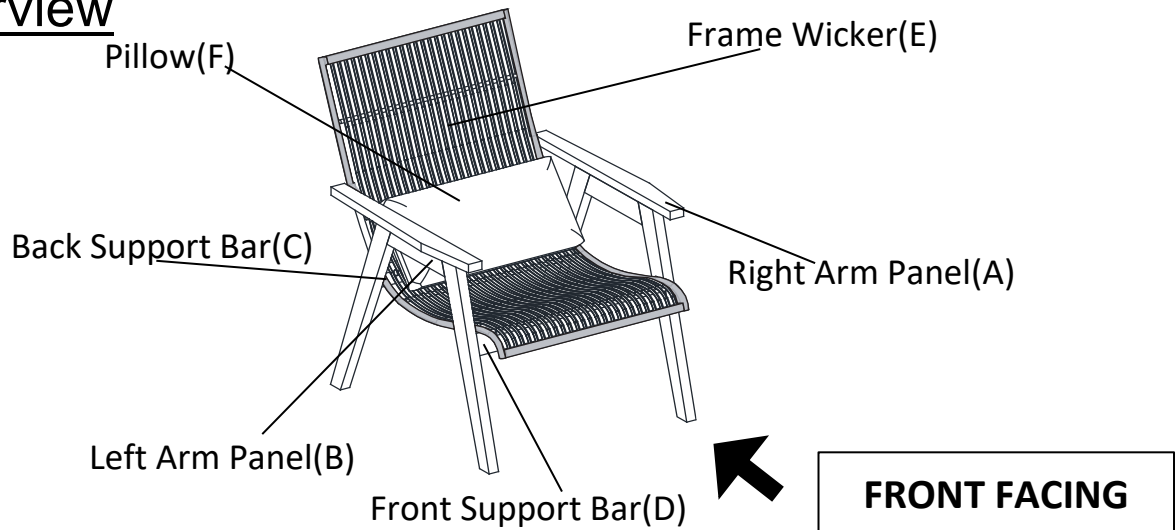

This Chair has multiple parts and may require up to 30 minutes to assemble. To give you an overview of the Chair parts, the above picture is to help you put the various parts into perspective. Please read through the instructions below to familiarise yourself with the parts and steps before assembly.

Step 1

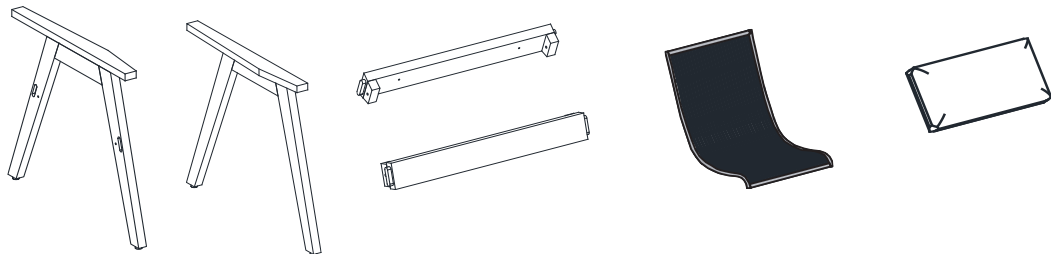

Unpack and place all parts on a clean, non-marring surface.

Step 2

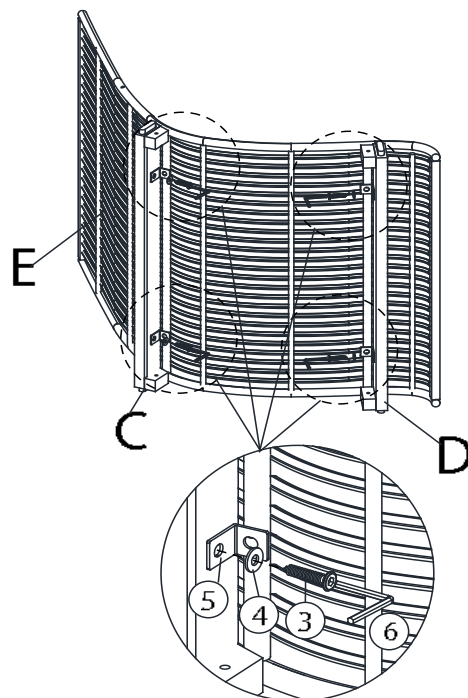

Place the Back Support Bar (C) and Front Support Bar (D) in an bottom position of Frame Wicker (E) as shown in the picture above, using the Allen Wrenches (⑥) to turn the Bolts (③) into the washer (④) and L-Bracket (⑤). Do not fully tighten the Bolts at this time.

Step 3

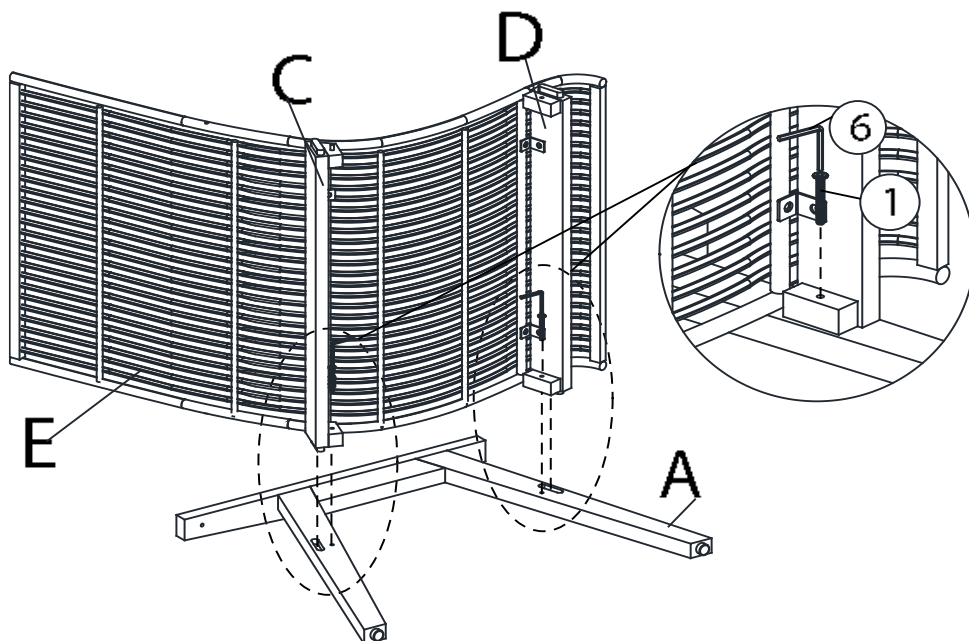

Place Right Arm Panel (A) onto the assembled frame from Step 2

Step 3.1: Align the dowels of Support Bar (C) into the positions in the Right Arm Panel (A).

Then, affix Support Bar (C) with Right Arm Panel (A) by using Bolt (①) and Allen (⑥).

Step 3.2: Attach the Right Arm Panel (A) onto Front Support Bar (D) by using Bolts (①) and Allen (⑥).

DO NOT FULLY TIGHTEN BOLTS.

Step 4

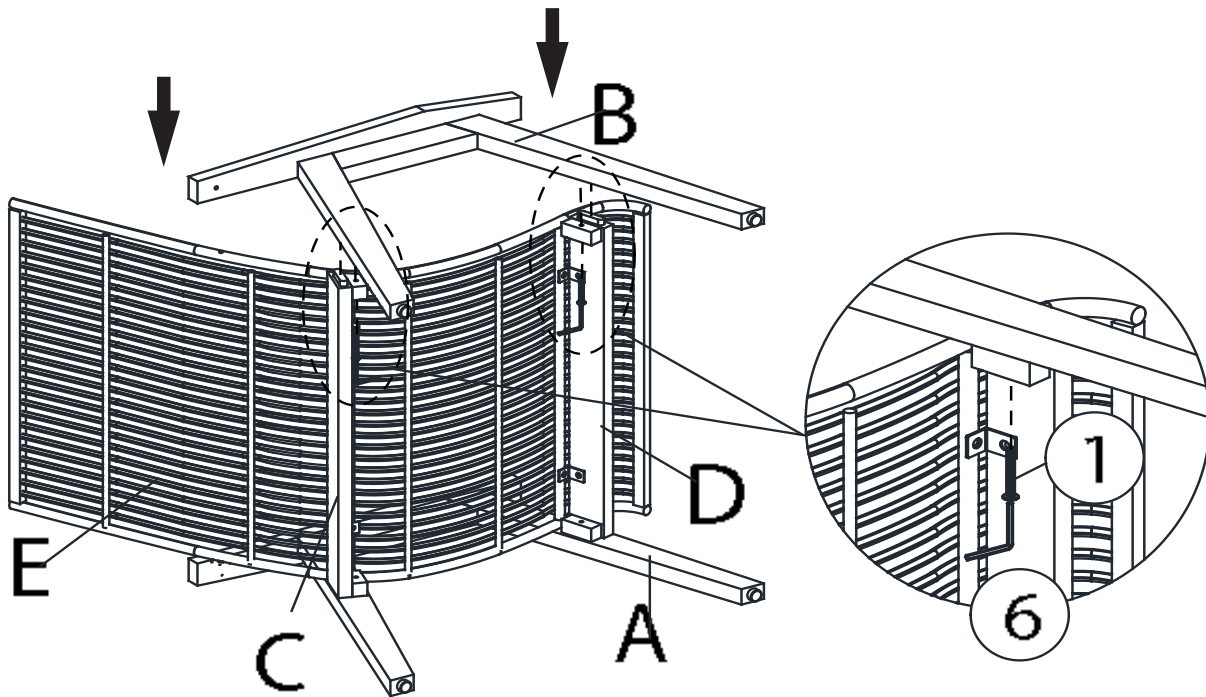

Place Left Arm Panel (B) onto the assembled frame from Step 3

Step 4.1: Align the dowels of Support Bar (C) into the positions in the Left Arm Panel (B).

Then, affix Support Bar (C) with Left Arm Panel (B) by using Bolt (①) and Allen (⑥).

Step 4.2: Attach the Left Arm Panel (B) onto Front Support Bar (D) by using Bolts (①) and Allen (⑥).

DO NOT FULLY TIGHTEN BOLTS.

Step 5

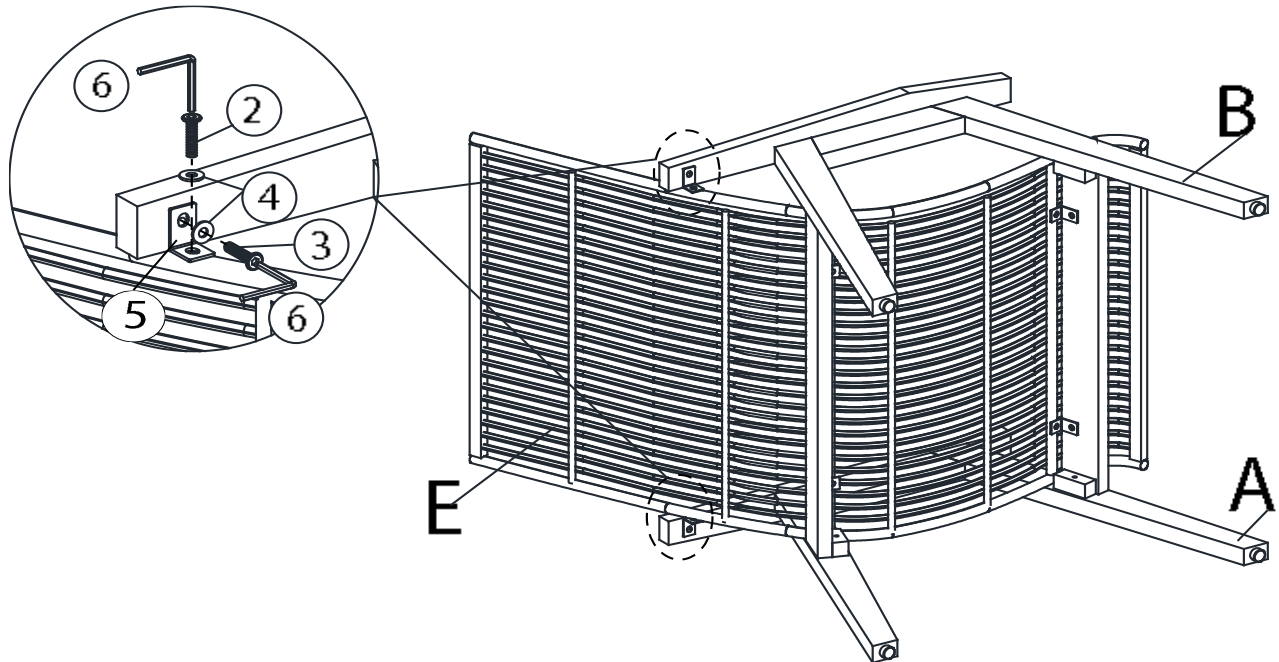

Place Right Arm Panel (A) and Left Arm Panel (B) onto the assembled frame from Step 4,
using the Allen Wrenches ((6)) to turn the Bolts ((3))
into the washer (4) and L-Bracket (5).
Do not fully tighten the Bolts at this time.

Step 6

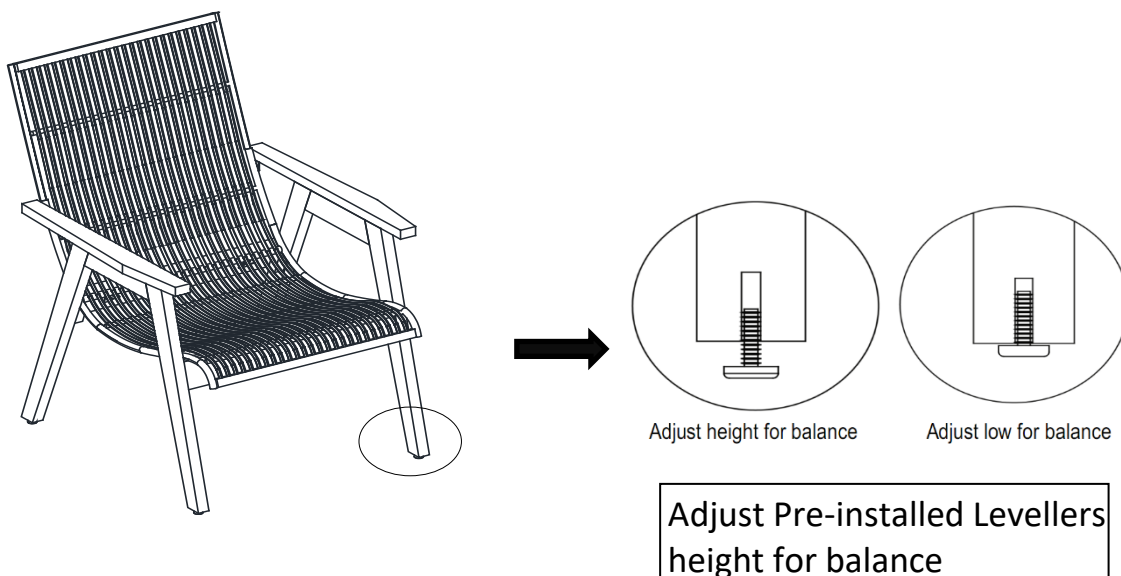

Inspect the Chair and make sure all parts are adequately connected.

In a sequential manner, tighten all Screws and Bolts at all joints.

With assistance from your adult partners, adjust the Levelers to desired height to avoid wobbles.

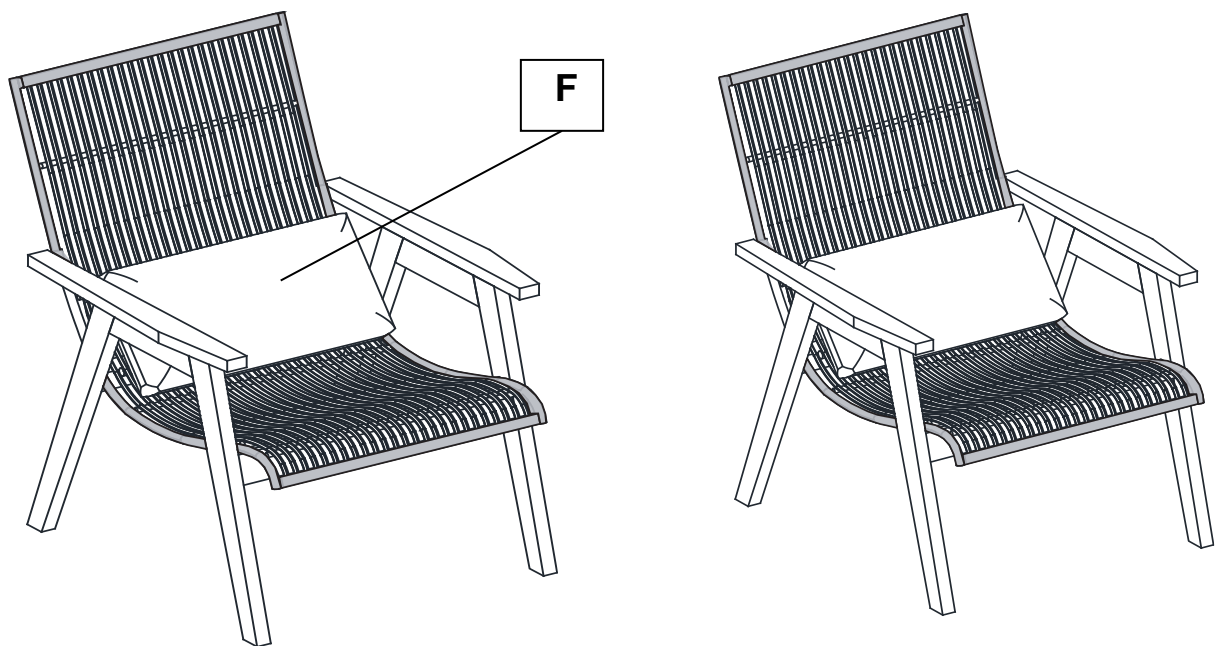

Turn the Chair right side up.

Place Pillow (F) to Frame Wicker E

Inspect the Chair and make sure all parts are adequately connected.

The Chair is ready to be used.

Caution: This Chair can only be used on a flat, level surface.

Questions & Answers about Proposition 65

- What is Proposition 65?

Proposition 65 requires businesses to provide warnings to Californians about significant exposures to chemicals that cause cancer, birth defects or other reproductive harm. These chemicals can be in the products that Californians purchase, in their homes or workplaces, or that are released into the environment. By requiring that this information be provided, Proposition 65 enables Californians to make informed decisions about their exposures to these chemicals.

Proposition 65 also prohibits California businesses from knowingly discharging significant amounts of listed chemicals into sources of drinking water.

Proposition 65 requires California to publish a list of chemicals known to cause cancer, birth defects or other reproductive harm. This list, which must be updated at least once a year, has grown to include approximately 900 chemicals since it was first published in 1987.

- What types of chemicals are on the Proposition 65 list?

The list contains a wide range of naturally occurring and synthetic chemicals that include additives or ingredients in pesticides, common household products, food, drugs, dyes, or solvents. Listed chemicals may also be used in manufacturing and construction, or they may be byproducts of chemical processes, such as motor vehicle exhaust.

- What does a warning mean?

If a warning is placed on a product label or posted or distributed at a workplace, a business, or in rental housing, the business issuing the warning is aware or believes that it is exposing individuals to one or more listed chemicals.

By law, a warning must be given for listed chemicals unless the exposure is low enough to pose no significant risk of cancer or is significantly below levels observed to cause birth defects or other reproductive harm.

- Where can I get more information on Proposition 65?

If you have specific questions on the administration or implementation of Proposition 65, you can contact OEHHA's Proposition 65 program at P65.Questions@oehha.ca.gov, or by phone at (916) 445-6900.