











# Assembly Instructions

**Caution : You must read this before you proceed**

## Care & Maintenance



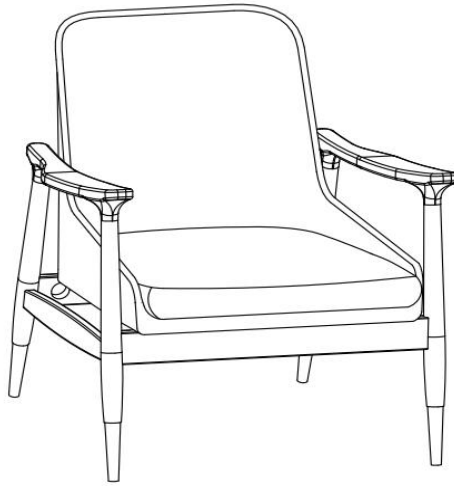

- ⊘  ● Not for commercial use. For residential use only.
  - ✓  ● Furniture may scratch floors. We recommend using furniture pads to protect your floors.
  - ⊘  ● Do not put hot items directly on furniture surface.
  - ⊘  ● Do not clean furniture with harsh cleansers or polish.
  - ⊘  ● Do not place furniture under direct sunlight.
  - ⊘  ● Do not place furniture near heating or cooling vents.
  - ⊘  ● Do not write on furniture without a padded barrier to protect the surface.
  - ⊘  ● Do not place furniture outside . For indoor use only.
  - ⊘  ● Stains may be removed with mild soap solution and damp cloth.
  - ⊘  ● Children should not climb or jump on the furniture.
- ✓  ● Dust and pick-up spills using a clean, non-colored, lint-free cloth.

Please look in carton for hardware packs and legs.

**Chair**









## Parts List

Label	Picture	Description	QTY
A		Seat Frame	1
B		Front Stretcher	1
C		Back Stretcher	1
D		Left Arm	1
E		Right Arm	1

F		Seat Cushion	1
---	-----------------------------------------------------------------------------------	--------------	---

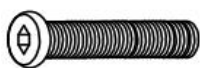
## Hardware

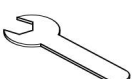
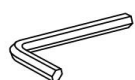
Label	Picture	Description	QTY
①		Full Thread Screw Ø5/16"×2-3/4"	5
②		Wood Dowel Ø10 x 30mm	9
③		Half Moon Washer 28 x 15 x 6.5mm	5
④		Nut Ø5/16"	5
⑤		Bolt Ø1/4" x 2"	5
⑥		Spring Washer Ø1/4"	5
⑦		Flat Washer Ø1/4"	5
⑧		Open wrench L95mm*T2.8mm, open-endØ12mm	1
⑨		Allen Wrench 4.0×21×57	1

## Assembly Preparation

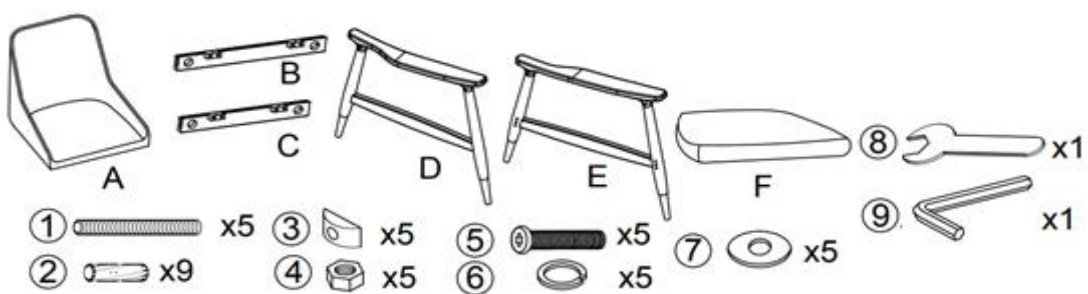
<p>Before Beginning Assembly :</p>	 <p>The diagram shows the assembly preparation for a chair. It includes: <ul style="list-style-type: none"> <li>Part A: Chair seat</li> <li>Part B: Chair backrest</li> <li>Part C: Chair base</li> <li>Part D: Chair frame</li> <li>Part E: Chair legs</li> <li>Part F: Seat cushion</li> <li>Hardware 1: Full Thread Screw (x5)</li> <li>Hardware 2: Wood Dowel (x9)</li> <li>Hardware 3: Half Moon Washer (x5)</li> <li>Hardware 4: Nut (x5)</li> <li>Hardware 5: Bolt (x5)</li> <li>Hardware 6: Spring Washer (x5)</li> <li>Hardware 7: Flat Washer (x5)</li> <li>Hardware 8: Open wrench (x1)</li> <li>Hardware 9: Allen Wrench (x1)</li> </ul> </p>
------------------------------------	-----------------------------------------------------------------------------------------------------------------------------------------------------------------------------------------------------------------------------------------------------------------------------------------------------------------------------------------------------------------------------------------------------------------------------------------------------------------------------------------------------------------------------------------------------------------------------------------------------------------------------------------------------------------------------------------------------------------------------------------------



- Read instructions, cover to cover-



- Have 2 adults on hand for assembly-



- Do not assemble on flooring or carpet-



- Assemble on a clean non-marring surface (packing foam)-



- Save all packaging until finished-

## Assembly Steps

### Overview

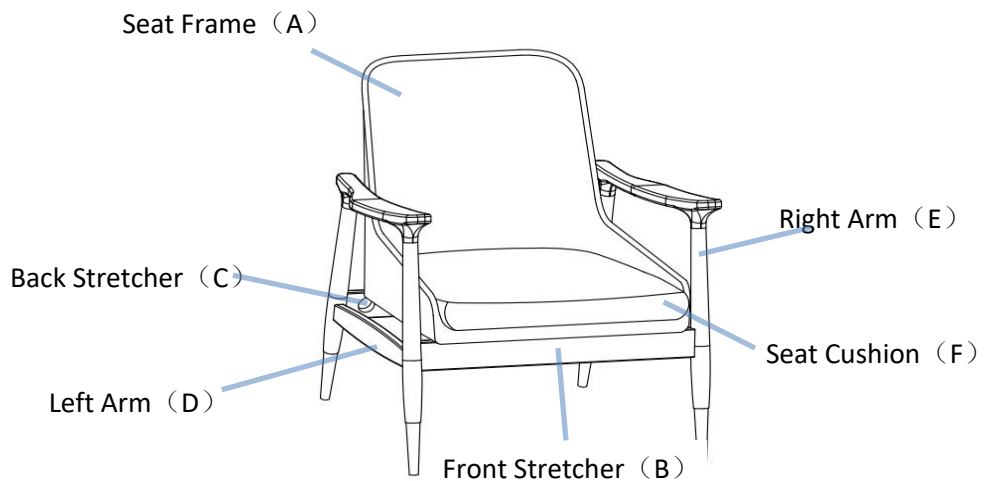

This chair has multiple parts and may require up to some 30 minutes to assemble. To give you an overview of the chair parts, the above picture is to help you put the various parts into perspective. Please read through the instructions below to familiarise yourself with the parts and steps before assembly.

### Step 1

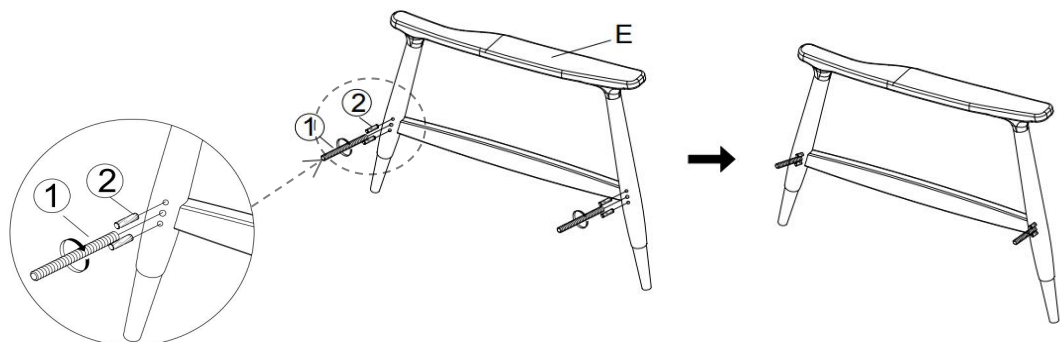

Install the Full Thread Screw (①) and Wood Dowel (②) on the Right Arm (E), as pictured above.

**Step 2**

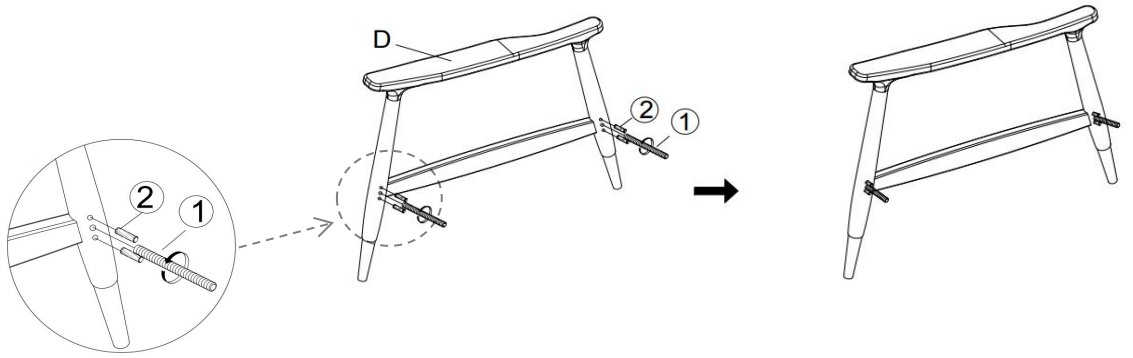

Install the Full Thread Screw (①) and Wood Dowel (②) on the Left Arm (D), as pictured above.

**Step 3**

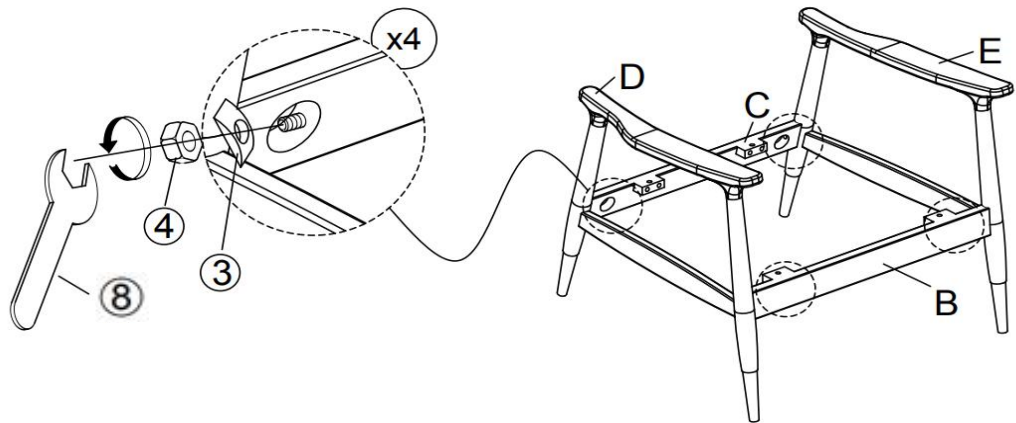

Attached Front Stretcher (B) and Back Stretcher (C) to Left Arm (D) by using Half Moon Washer (③) ,Nut (④) and Open wrench (⑧)  
Repeat the same process to install Front Stretcher (B) and Back Stretcher (C) to Right Arm(E), as pictured above.

**Step 4**

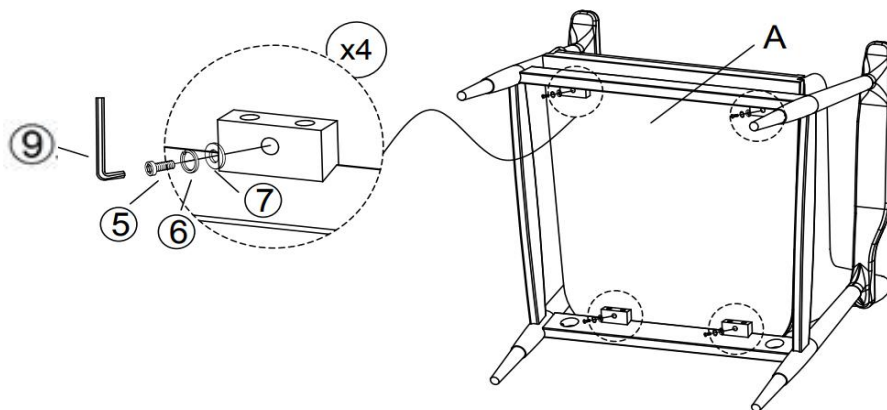

Attached Seat Frame (A) to Front Stretcher (B) and Back Stretcher (C) by using Bolt (⑤) ,Spring Washer (⑥), Flat Washer (⑦) and Allen Wrench (⑨)as pictured above.

Step 5

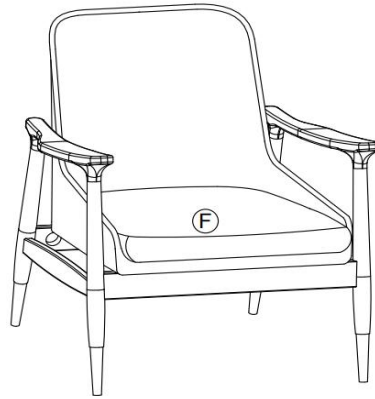

Put the Seat Cushion (F) on the Seat Frame (A).  
Your Chair is ready for use.  
This Chair can only be used on a flat, level surface.