

ASSEMBLY INSTRUCTION FOR ACME FURNITURE

MODEL# DN00153

Thank you for purchasing the quality product. Be sure to check all packing material carefully for small parts which may have come loose inside the carton during shipment. Separate, identify and count all parts and metal hardware. Compare with all parts list to be sure all parts are present. If any part(s) are missing or damaged, please contact your local furniture dealer. For efficient and speedy service, please indicate the model number and code letter of part(s) needed.

*****Do not fully tighten screws until fully assembled*****

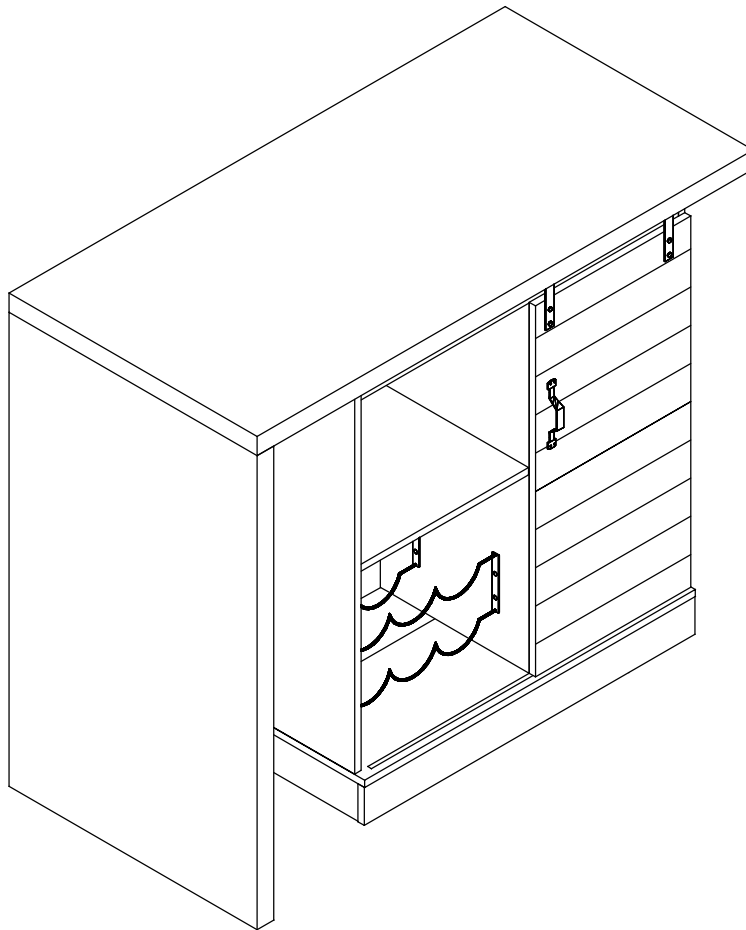

Attention:

*** Some number parts listed on the instruction sheet may not be in parts bag as they may already be assembled. Carefully check parts and packing materials prior to ordering replacements.

General Assembly Guidelines

- I. Ensure that all parts and hardware are available before beginning assembly.
- II. Follow each step carefully to ensure the proper assembly of this product.
- III. Two people are recommended for ease in the assembly of this product.
- IV. The three main types of hardware used to assemble this product are : wood dowels , screws and bolts.
- V. The provided glue is to secure wood dowels in place . When first inserting dowels , locate the appropriate hole for the dowel , place a small amount of glue in the hole and insert the dowel . Wipe away excess glue immediately.

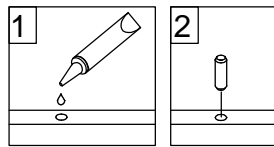

In future assembly steps when dowels are necessary to attach assembly parts together , place a small amount of glue on the end of the dowel before attaching parts together . Wipe away excess glue immediately.

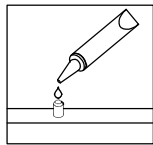

- VI. A Phillips head screwdriver is required for the assembly of this product .

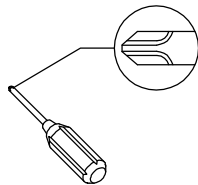



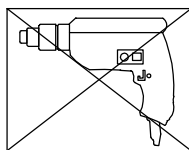



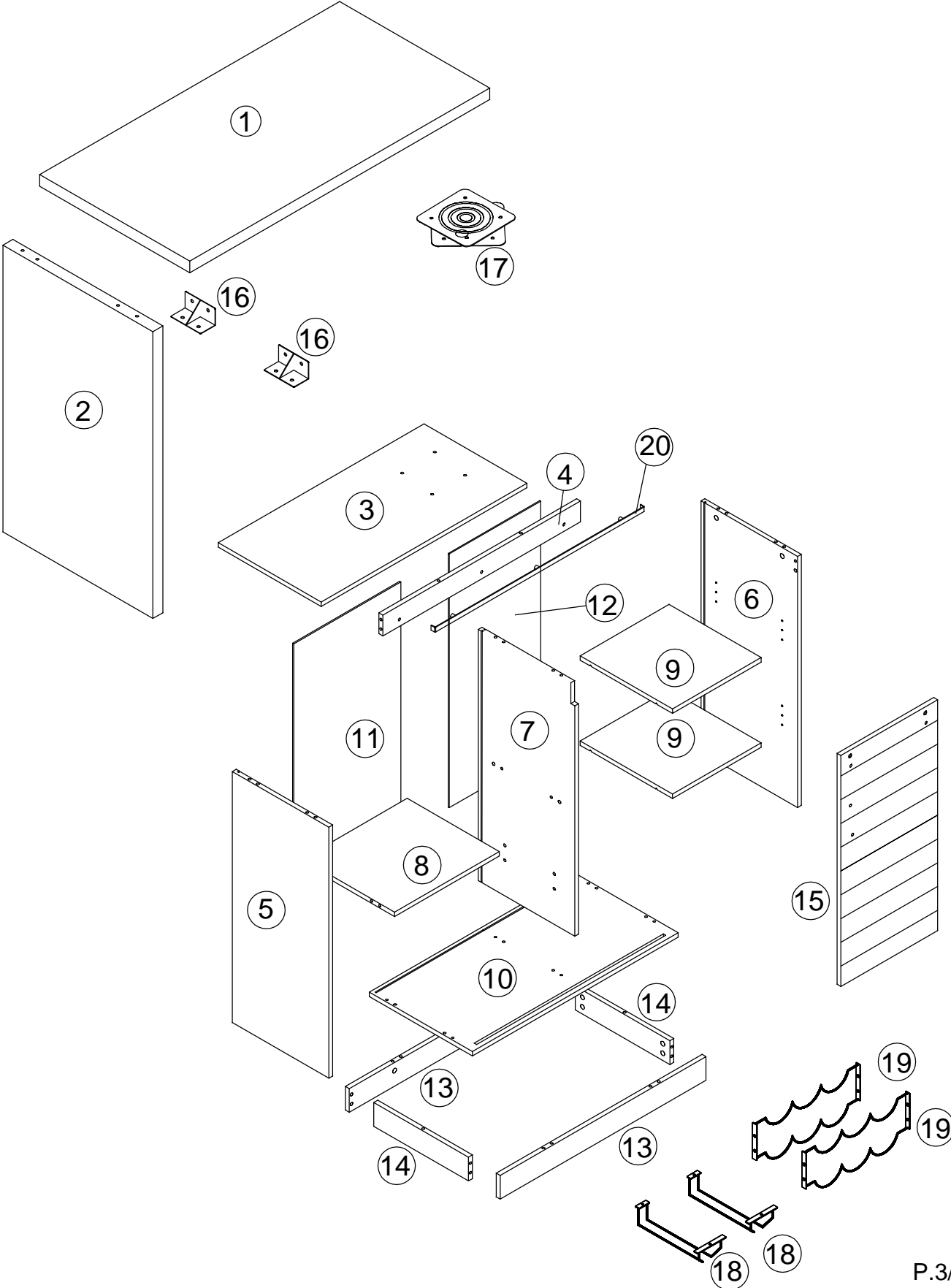



















- VII. Power tools should not be used to assemble this product .



Component Parts



Hardware List

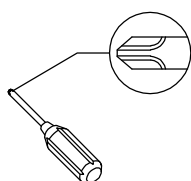

A		Ø8x30mm	Wooden dowel	26	pcs	Q		Glue tube	1	pcs
B		Ø6x35mm	Cam bolt	26	pcs	R		5mm	1	pcs
C		Ø15x11mm	Cam lock	26	pcs	S		M 8X30mm Bolt	4	pcs
D		Ø30mm	Sticker	26	pcs	T		M 8X20mm Bolt	12	pcs
E		Ø6x50mm	Screw	6	pcs	U		M8mm Nut	6	pcs
F		Ø1/4x12mm	Bolt	12	pcs	V		Wrench	1	pcs
G		Ø1/4x25mm	Bolt	3	pcs	W		M8mm Washer	14	pcs
H			Plastic wedge	12	pcs	X		M8X1013mm Screw rod	2	pcs
I		Ø4x16mm	Screw	2	pcs	Y		Sleeve	1	pcs
J		Ø3x17mm	Screw	12	pcs	Z		M4*12mm Bolt	4	pcs
K			Hanging wheel	2	pcs					
L			Positioning iron	2	pcs					
M		Ø3.5x14mm	Screw	4	pcs					
N		4mm	Hex Key	1	pcs					
O			Handle	1	pcs					
P		Ø8x5x16mm	Shelf support pin	8	pcs					



Philips head screwdriver required for assembly
(not included)



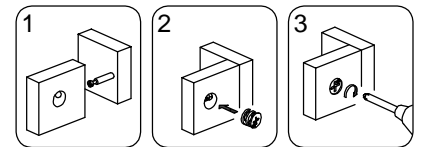
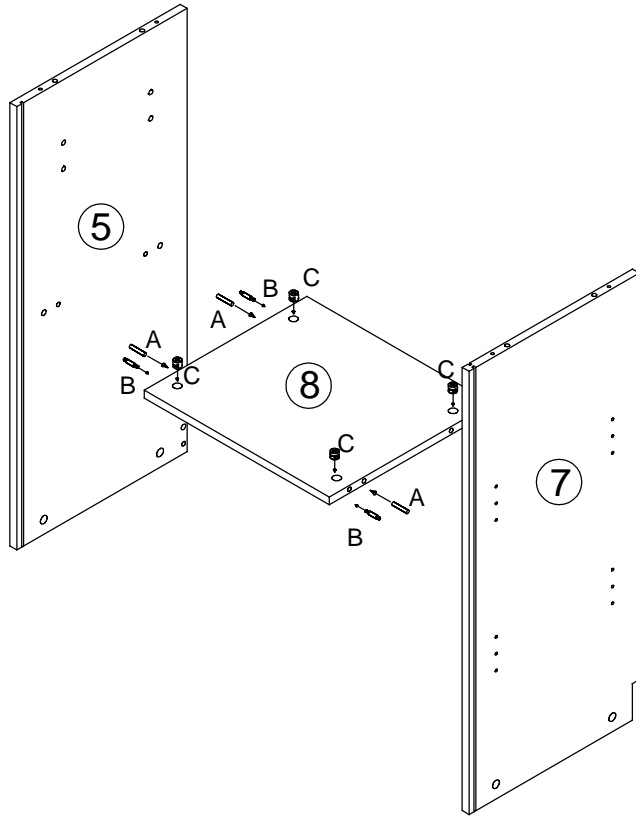

*The hardware quantities listed above are required for proper assembly.
Some extra hardware may also have been included.*

Step 1

A x 4	B x 4	C x 4
		
Ø8x30mm	Ø6x35mm	Ø15x11mm



Step 2

A x 2	B x 2	C x 2	G x 3	N x 1
				
Ø8x30mm	Ø6x35mm	Ø15x11mm	Ø1/4"x25mm	M4mm

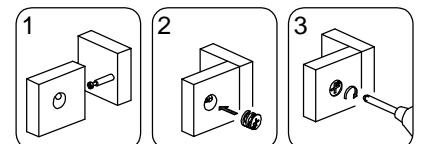
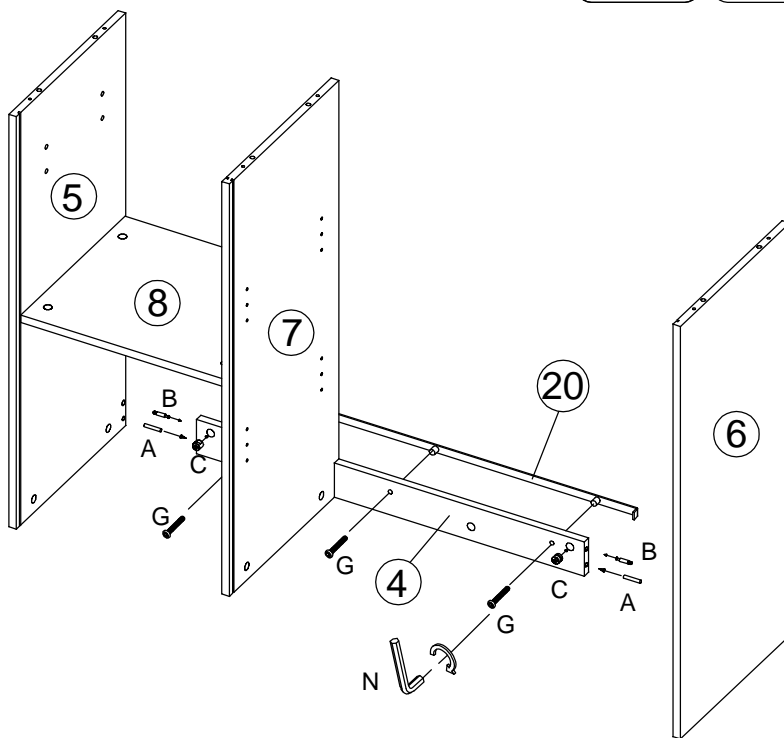

Step 3

A x 6
Ø8x30mm

B x 8
Ø6x35mm

C x 8
Ø15x11mm

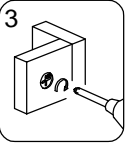
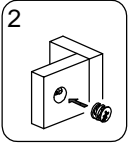
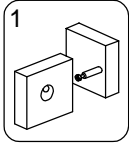
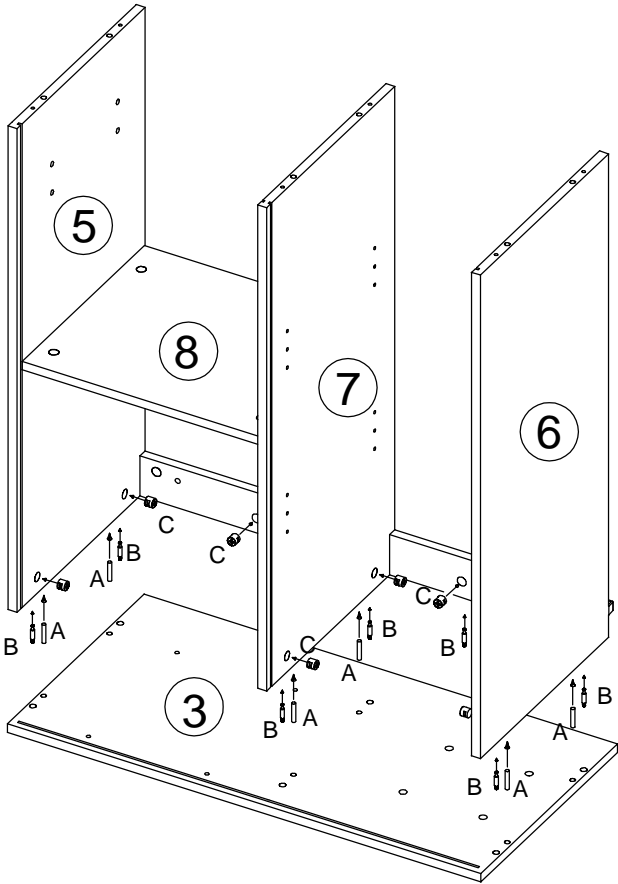

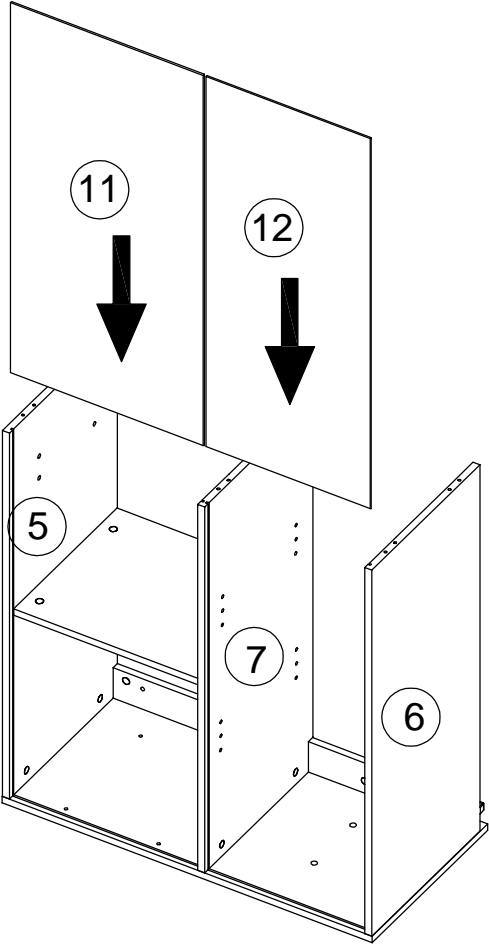

Step 4

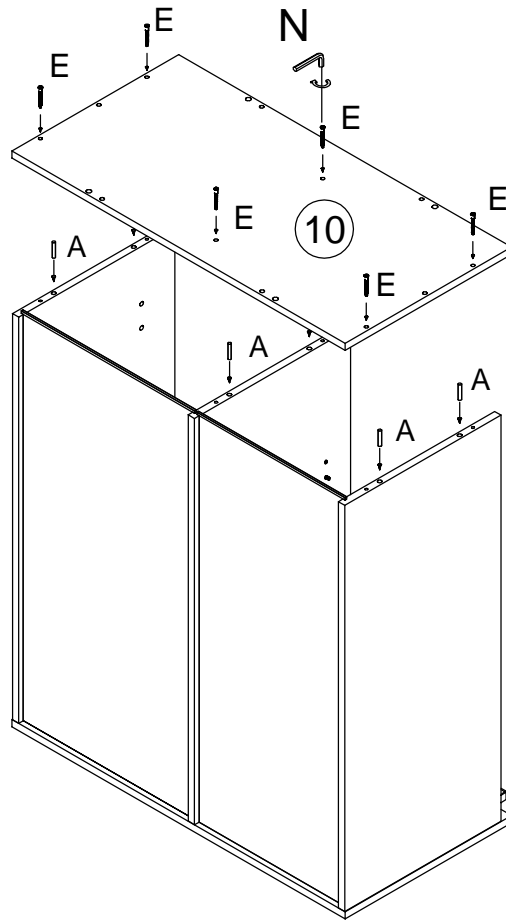

Step 5





A x 6

Ø8x30mm

E x 6

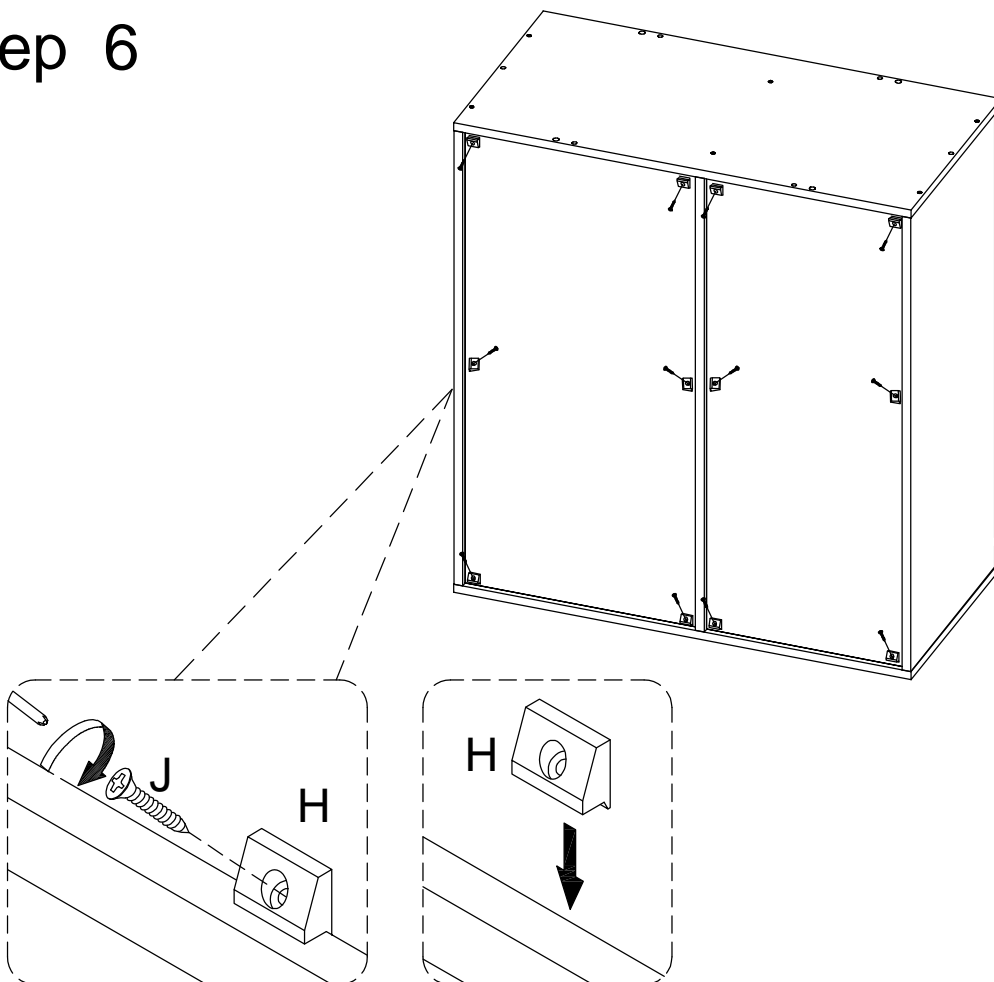
Ø6x50mm

N x 1

M4mm



Step 6



H x 12



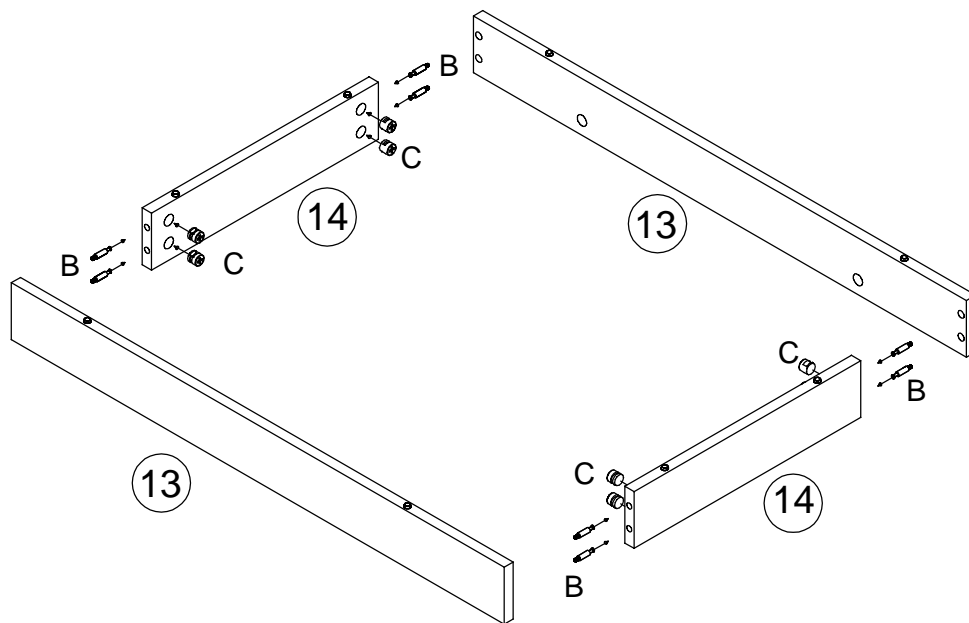

J x 12

Ø3x17mm

Step 7

B x 8	C x 8
	
Ø6x35mm	Ø15x11mm



Step 8

A x 6	B x 4	C x 4
		
Ø8x30mm	Ø6x35mm	Ø15x11mm

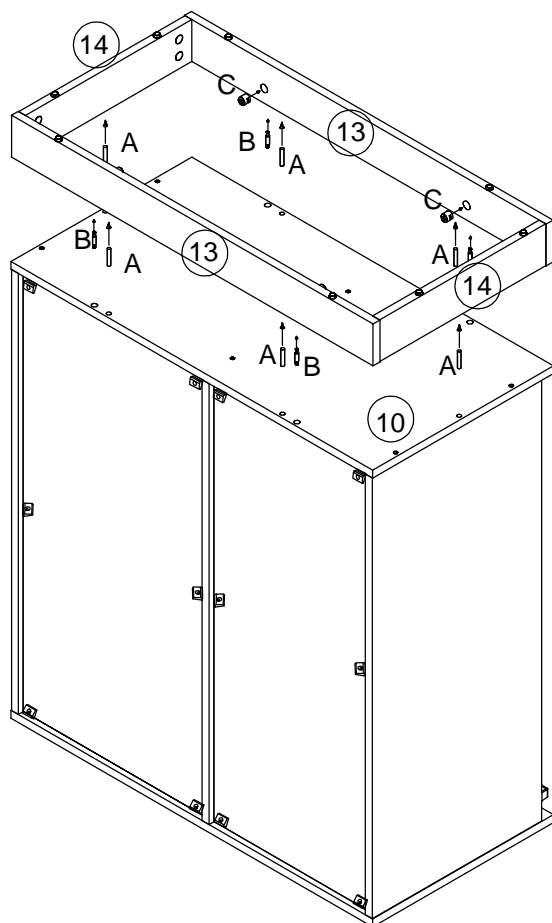

Step 9

D x 26
○

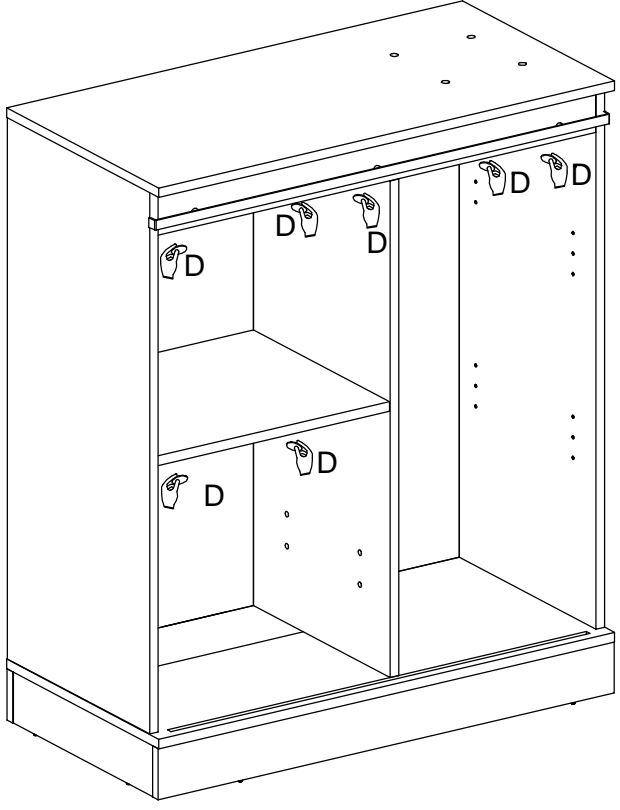

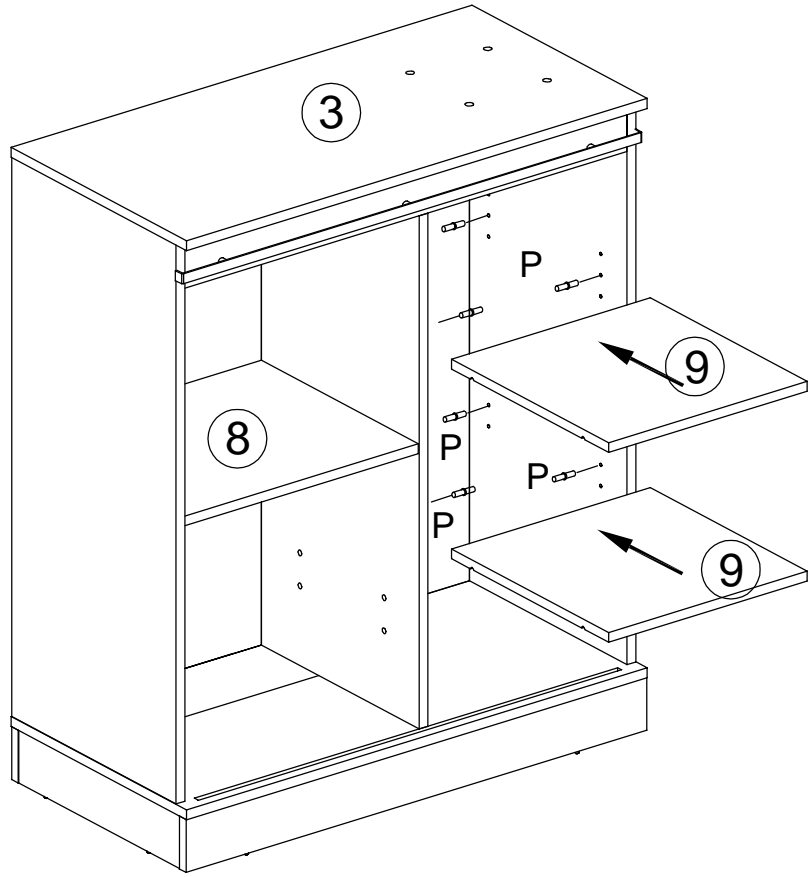

Step 10

P x 8
P



Step 11

F x 8  Ø1/4"x12mm	N x 1  4mm	Z x 4  M4x12mm
--	---	---

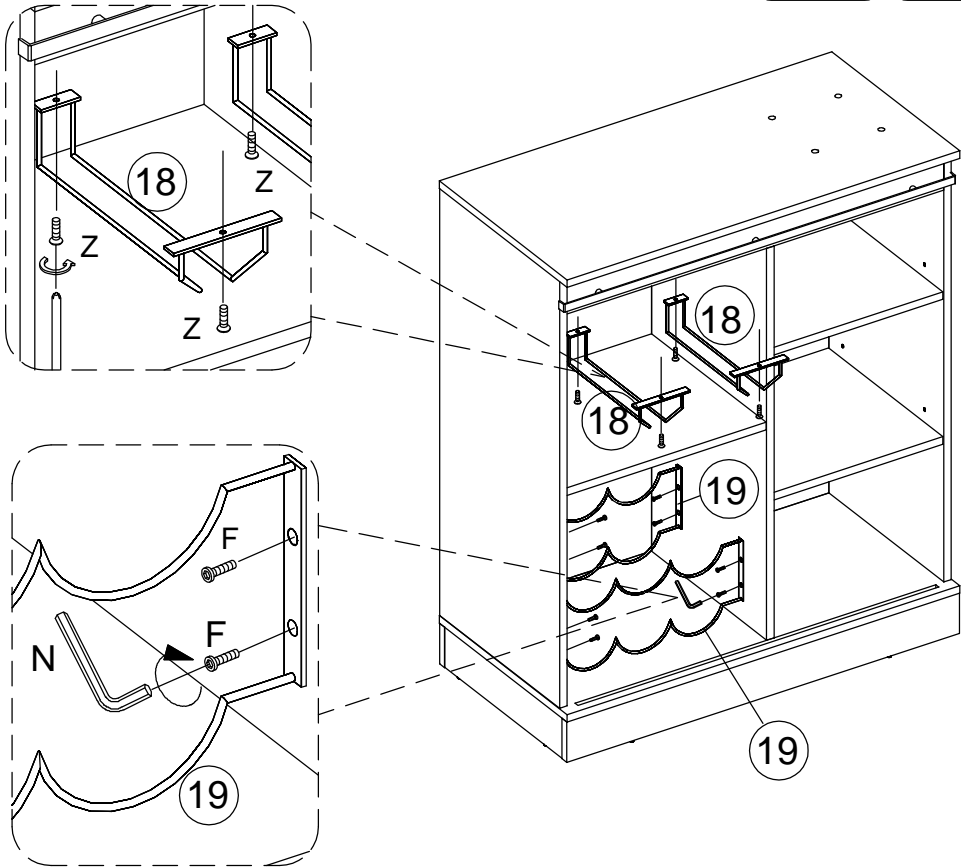



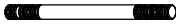

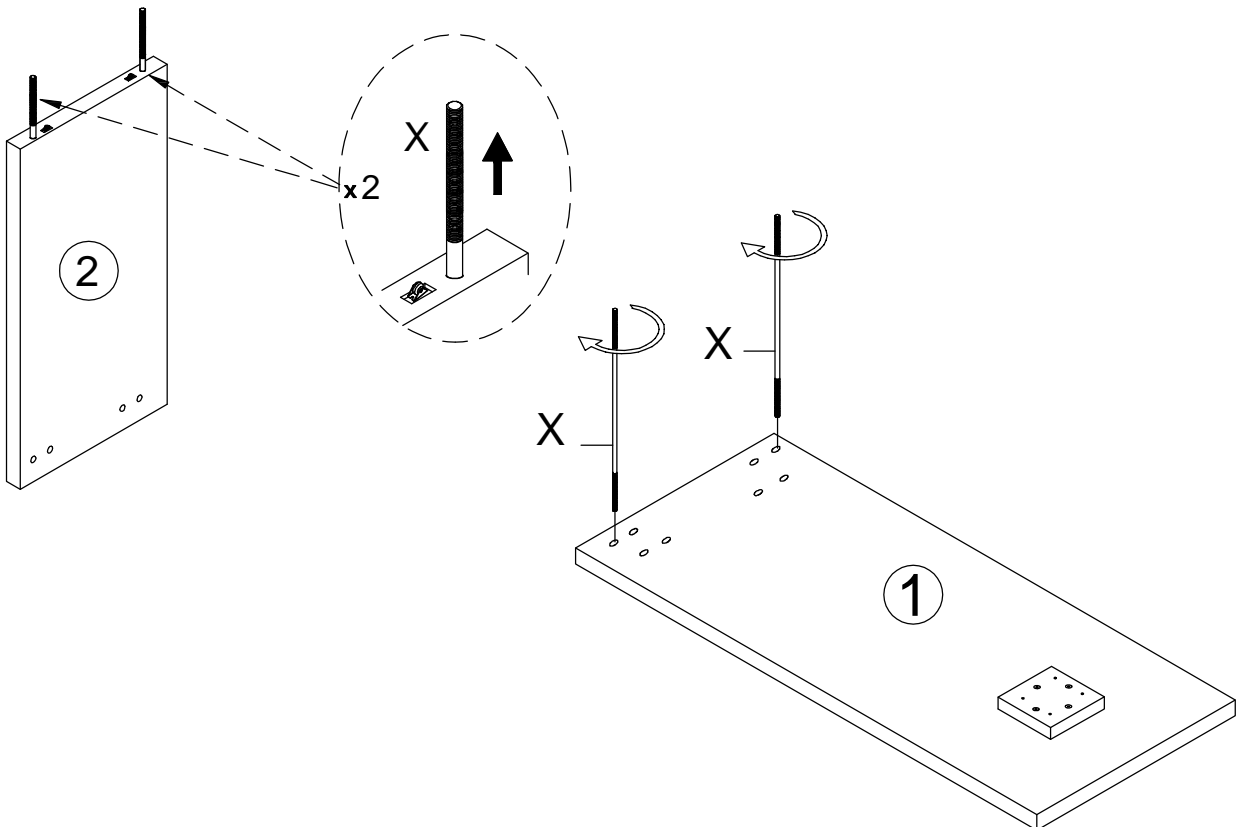
Step 12

X x 2  M 8X1013mm
--



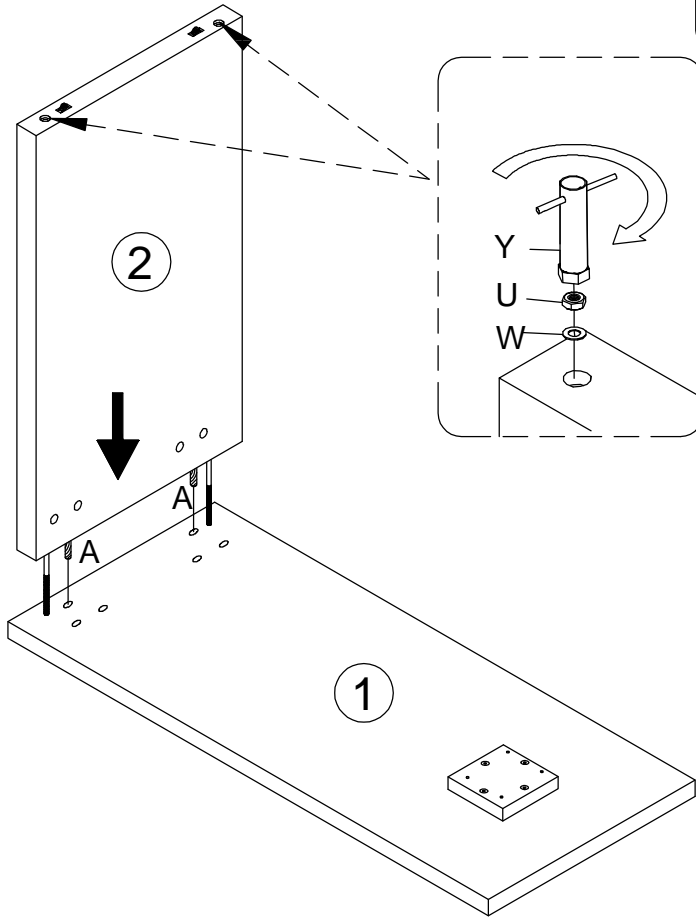

Step 13

A x 2  Ø8x30mm	U x 2  M8mm	W x 2  M8mm	Y x 1 
--	--	--	--





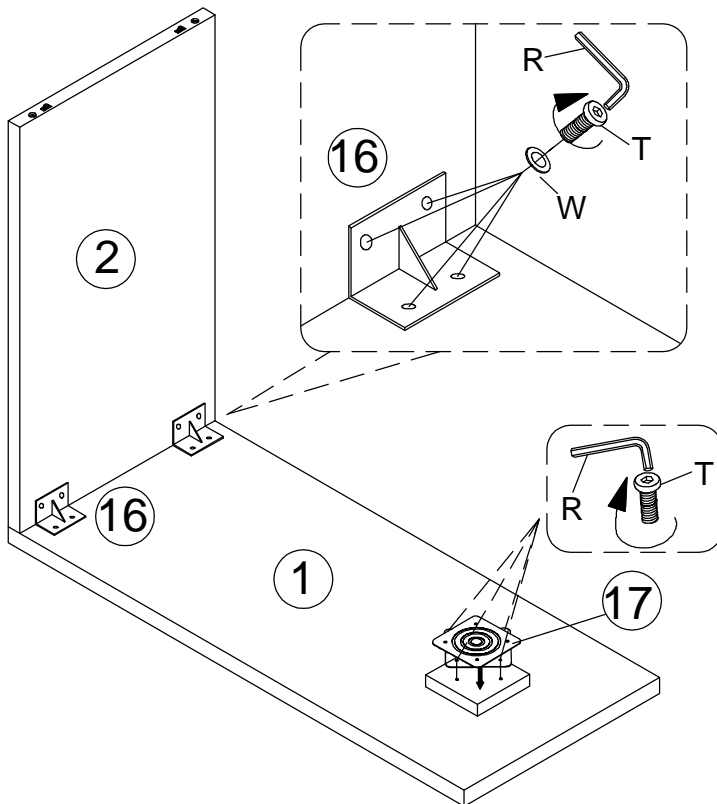

Step 14

R x 1  M5mm	T x 12  M 8X20mm	W x 8  M8mm
--	---	--







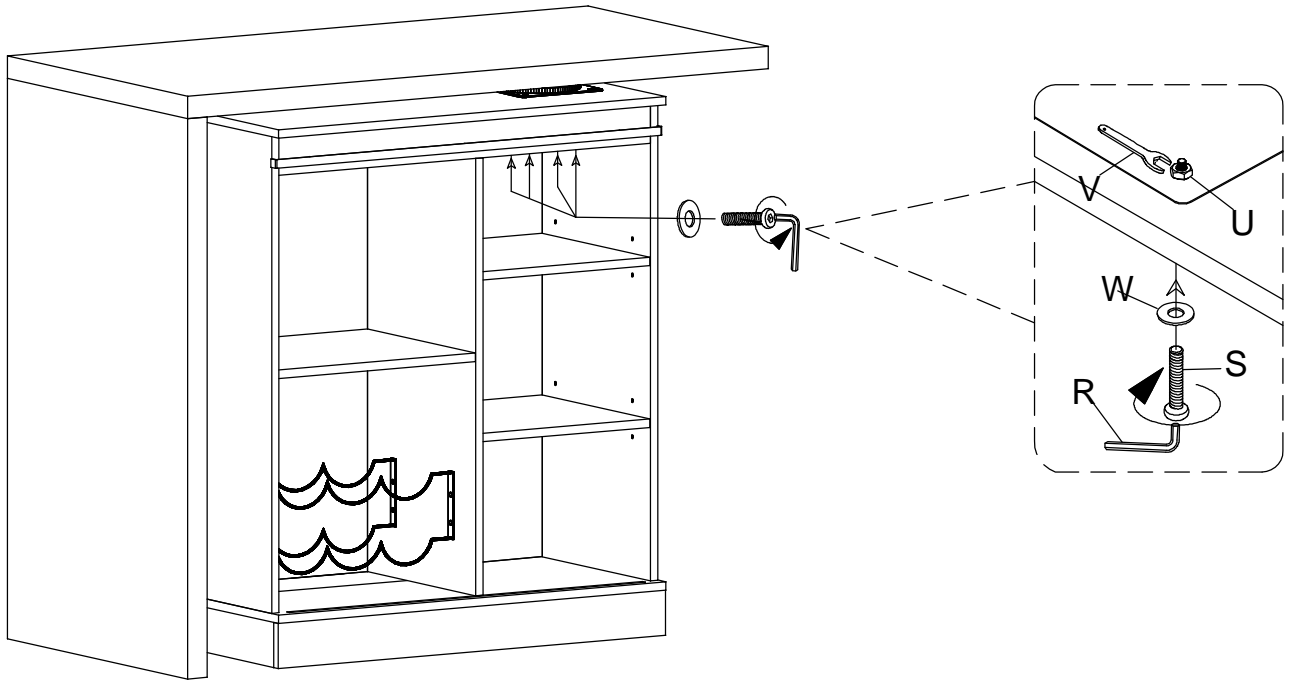

Step 15

R x 1  M5mm	S x 4  M 8X30mm	U x 4  M8mm	V x 1  M8mm	W x 4  M8mm
--	--	--	--	--



Step 16

F x 4  Ø1/4"x12mm	I x 2  Ø4x16mm	M x 4  Ø3.5x14mm	K x 2 	L x 2 	O x 1 
--	---	---	--	--	--

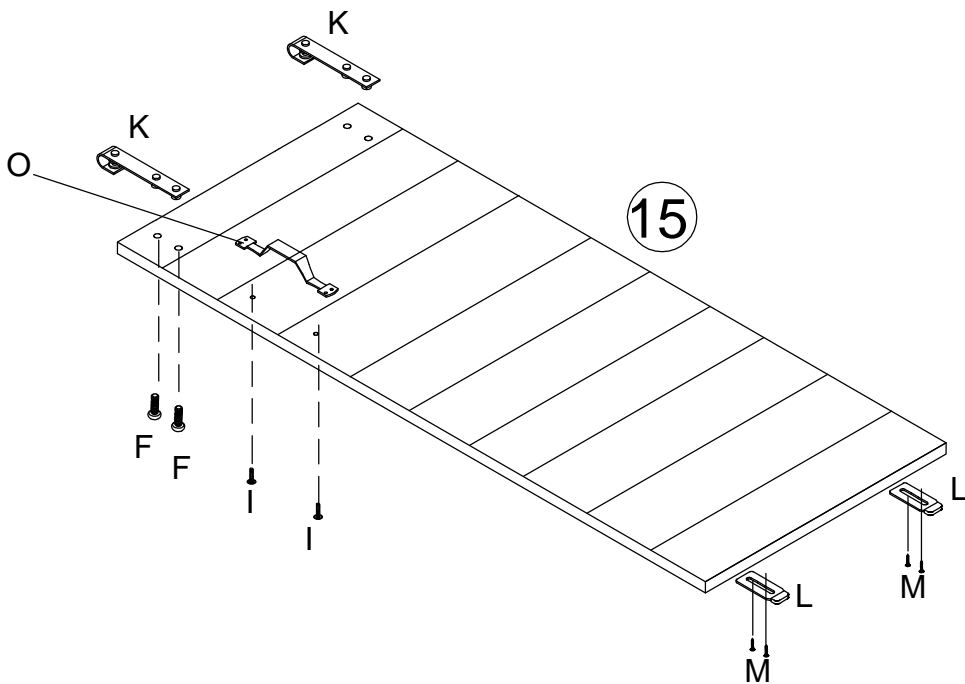

Step 17

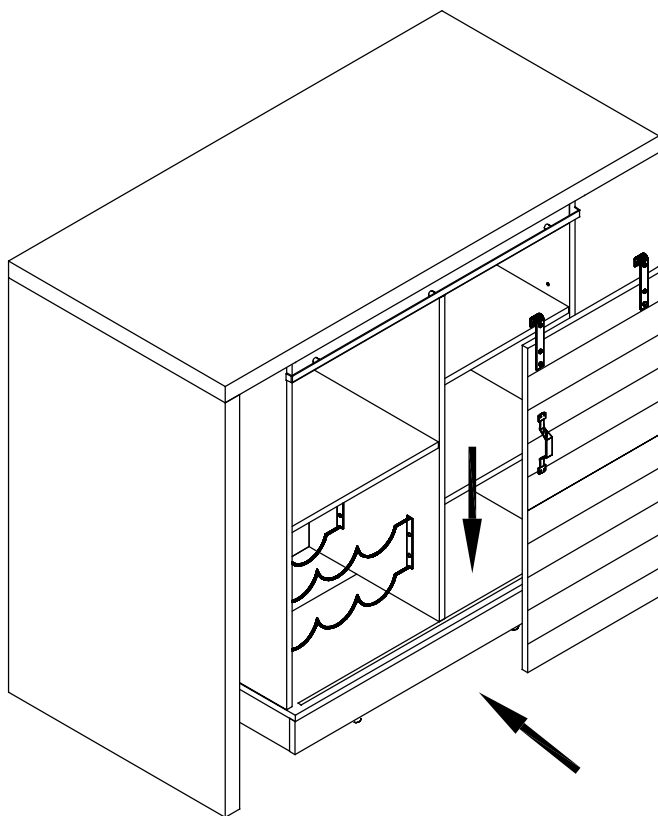

Step 18

