

ASSEMBLY INSTRUCTION FOR ACME FURNITURE

MODEL#AC00403

Thank you for purchasing the quality product. Be sure to check all packing material carefully for small parts which may have come loose inside the carton during shipment. Separate, identify and count all parts and metal hardware. Compare with all parts list to be sure all parts are present. If any part(s) are missing or damaged, please contact your local furniture dealer. For efficient and speedy service, please indicate the model number and code letter of part(s) needed.

*****Do not fully tighten screws until fully assembled*****



Attention:

*****Some number parts listed on the instruction sheet may not be in parts bag as they may already be assembled. Carefully check parts and packing materials prior to ordering replacements.**

General Assembly Guidelines

- I. Ensure that all parts and hardware are available before beginning assembly.
- II. Follow each step carefully to ensure the proper assembly of this product.
- III. Two people are recommended for ease in the assembly of this product.
- IV. The three main types of hardware used to assemble this product are: wood dowels, screws and bolts.
- V. The provided glue is to secure wood dowels in place. When first inserting dowels, locate the appropriate hole for the dowel, place a small amount of glue in the hole and insert the dowel. Wipe away excess glue immediately.

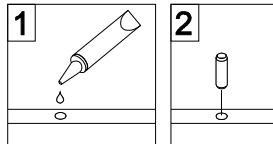

In future assembly steps when dowels are necessary to attach assembly parts together, place a small amount of glue on the end of the dowel before attaching parts together. Wipe away excess glue immediately.

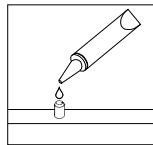

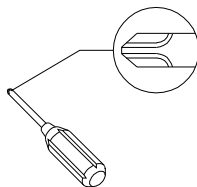

- VI. A Phillips head screwdriver is required for the assembly of this product.



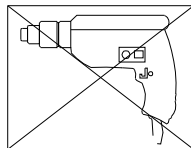



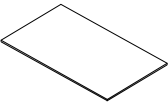
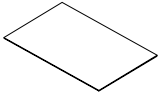
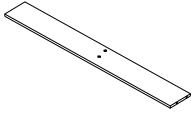
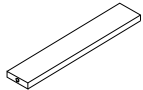
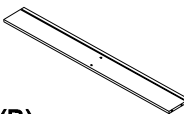
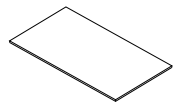
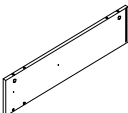
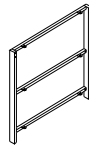
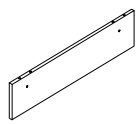
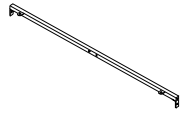
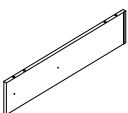
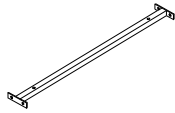

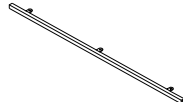
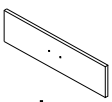
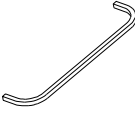
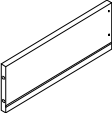
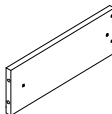
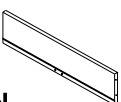









- VII. Power tools should not be used to assemble this product.



COMPONENT PARTS

DESCRIPTION	PART NAME	QTY(PCS)	DESCRIPTION	PART NAME	QTY(PCS)
①	Table Top 	1	⑫	Drawer Bottom Panel 	2
②	Table Bottom(F) 	1	⑬	Support Panel 	2
③	Table Bottom(B) 	1	⑭	Shelf 	2
④	Left side pane 	1	⑮	Metal tube 	2
⑤	Right side panel 	1	⑯	Metal tube 	2
⑥	Middle side panel 	1	⑰	Metal tube 	1
⑦	Back plane 	2	⑱	Metal tube 	4
⑧	Drawer Front Panel 	2	⑲	Metal tube 	1
⑨	Drawer Side Panel(L) 	2			
⑩	Drawer Side Panel(R) 	2			
⑪	Drawer Back Panel 	2			1

Hardware List

A		Ø8x30mm	Wooden dowel	6 pcs
B		Ø6x35mm	Cam bolt	24 pcs
C		Ø15x11mm	Cam lock	24 pcs
D		Ø30mm	Sticker	24 pcs
E		Ø6x50mm	Screw	4 pcs
F		Ø1/4"x30mm	Bolt	12 pcs
G		Ø1/4"x12mm	Bolt	36 pcs
H		4mm	Allen Key	1 pcs
I			Glue tube	1 pcs
J			Handle	2 pcs
K		Ø4x30mm	Screw	12 pcs
L		Ø3.5x14mm	Bolt	20 pcs
M			Drawer slider	2 pcs
N			Plastic wedge	8 pcs
O		Ø3x17mm	Screw	8 pcs
P		Ø4x18mm	Screw	4 pcs
Q		Ø1/4"x57mm	Bolt	4 pcs

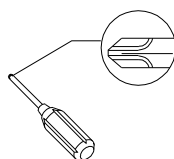

Philips head screwdriver required for assembly
(not included)

*The hardware quantities listed above are required for proper assembly.
Some extra hardware may also have been included.*

Step 1



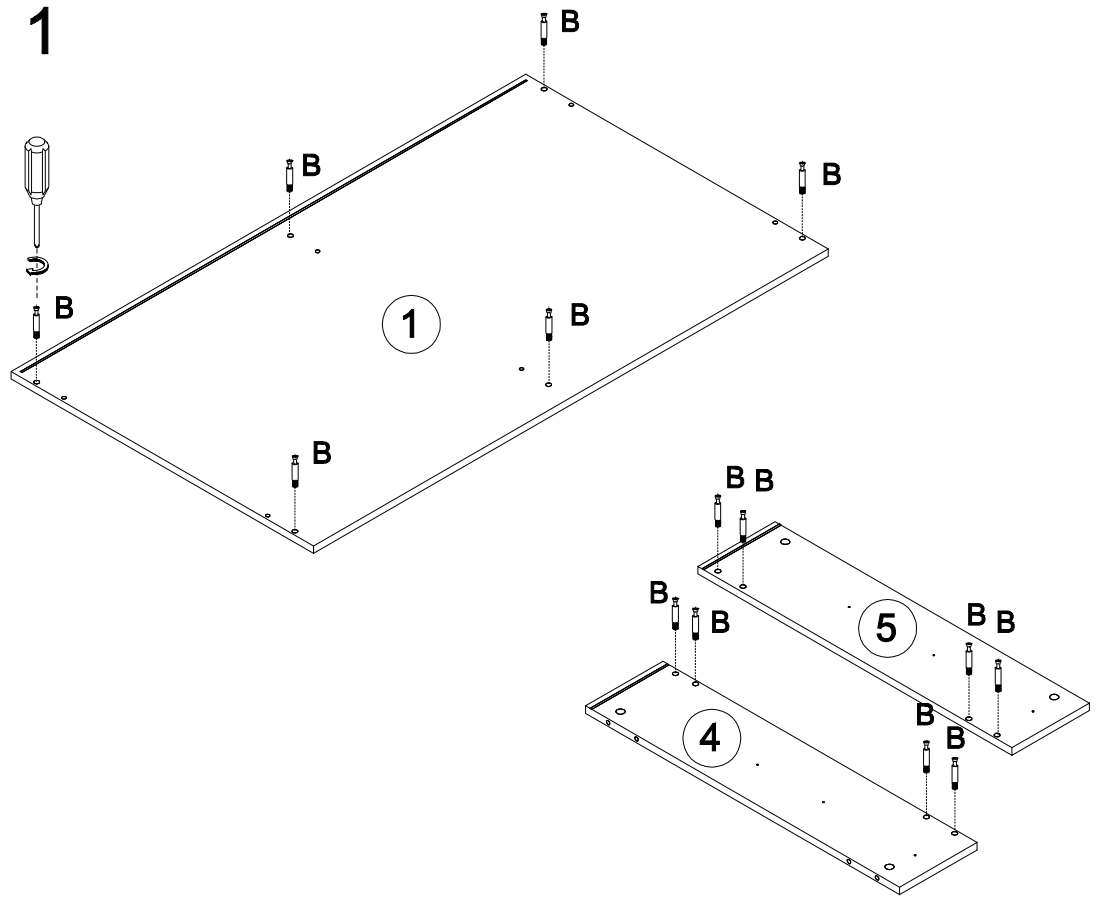

B x 14
Ø6x35mm

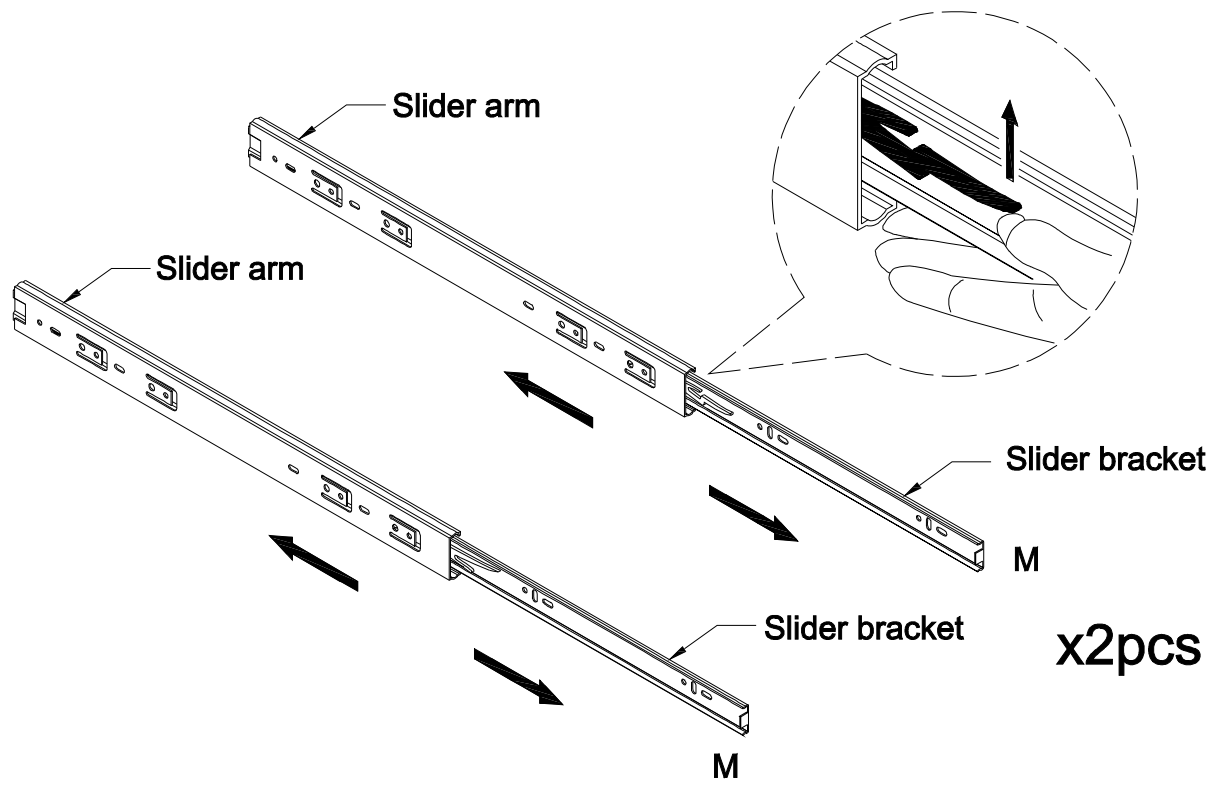

Step 2



Step 3

F x 2  Ø1/4"x30mm	H x 1  4mm	M x 2 	L x 12  Ø3.5x14mm
-------------------------------------------------------------------------------------------------------------------	------------------------------------------------------------------------------------------------------------	-----------------------------------------------------------------------------------------------------	-------------------------------------------------------------------------------------------------------------------

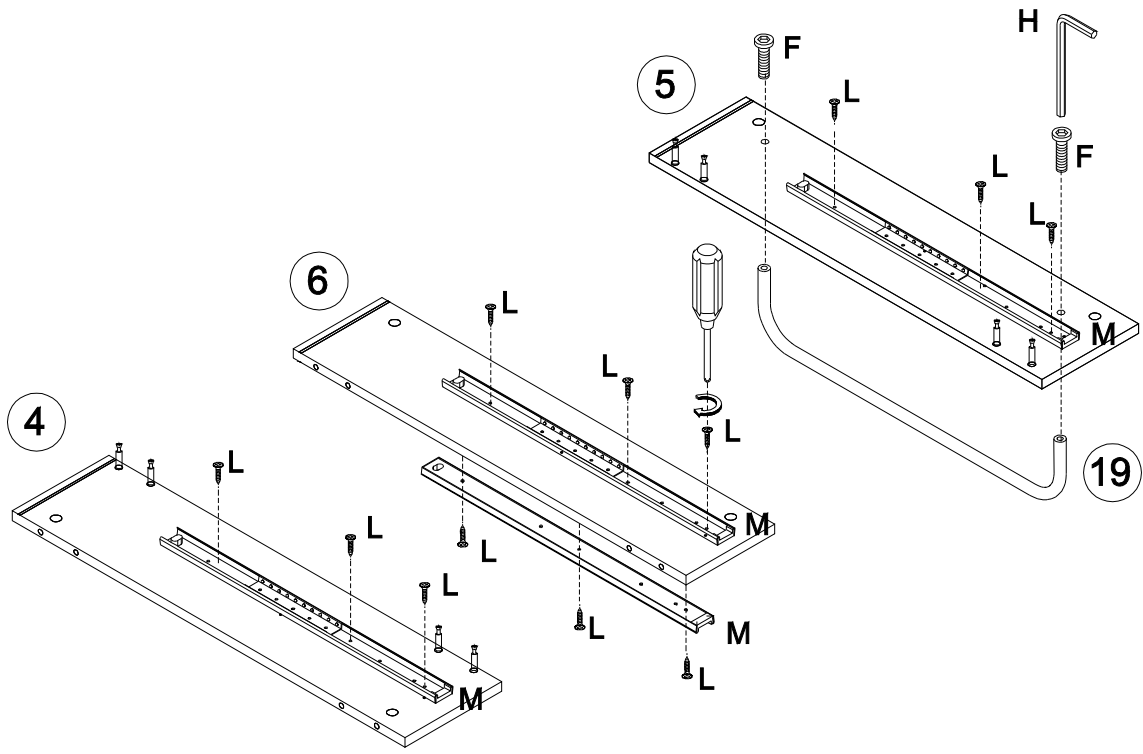

Step 4

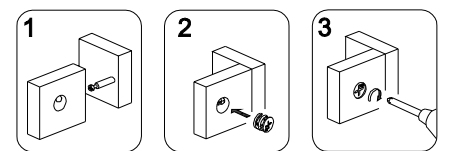
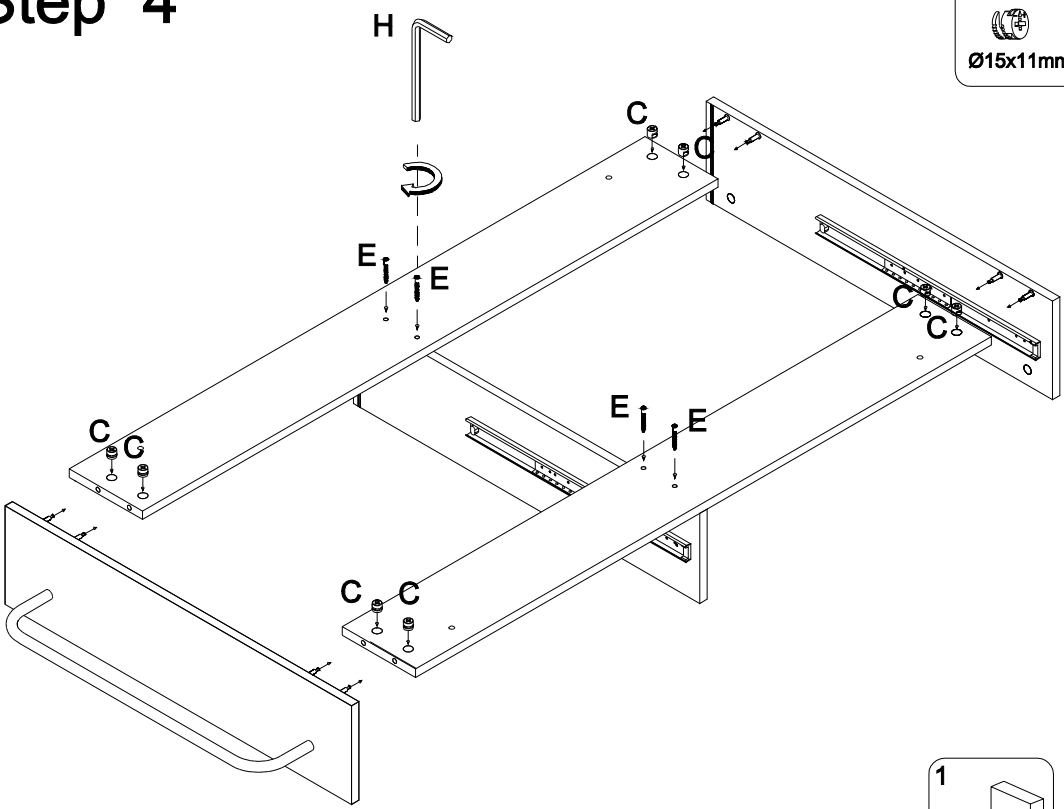

C x 8  Ø15x11mm	E x 4  Ø6x50mm	H x 1  4mm
-------------------------------------------------------------------------------------------------------------------	------------------------------------------------------------------------------------------------------------------	--------------------------------------------------------------------------------------------------------------

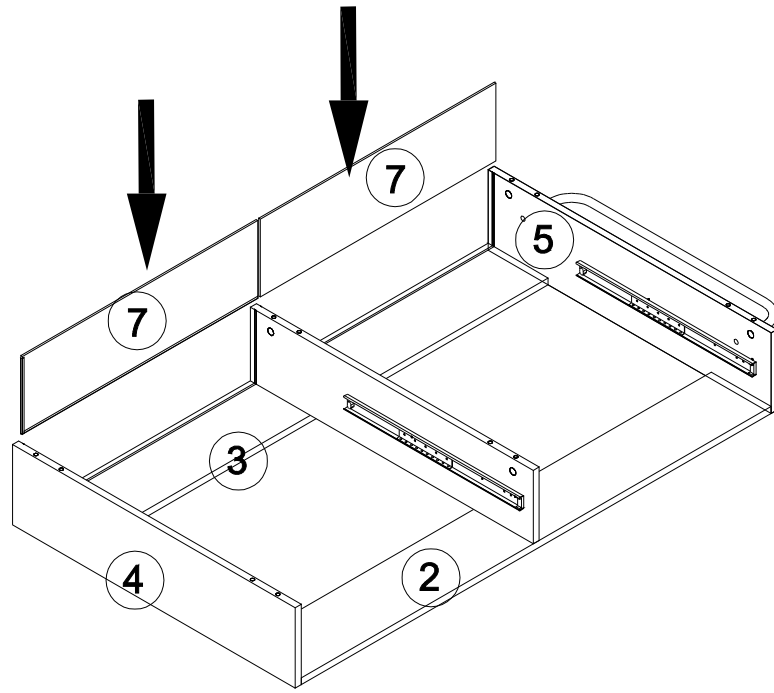

Step 5



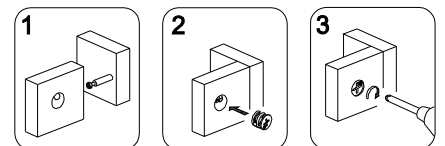
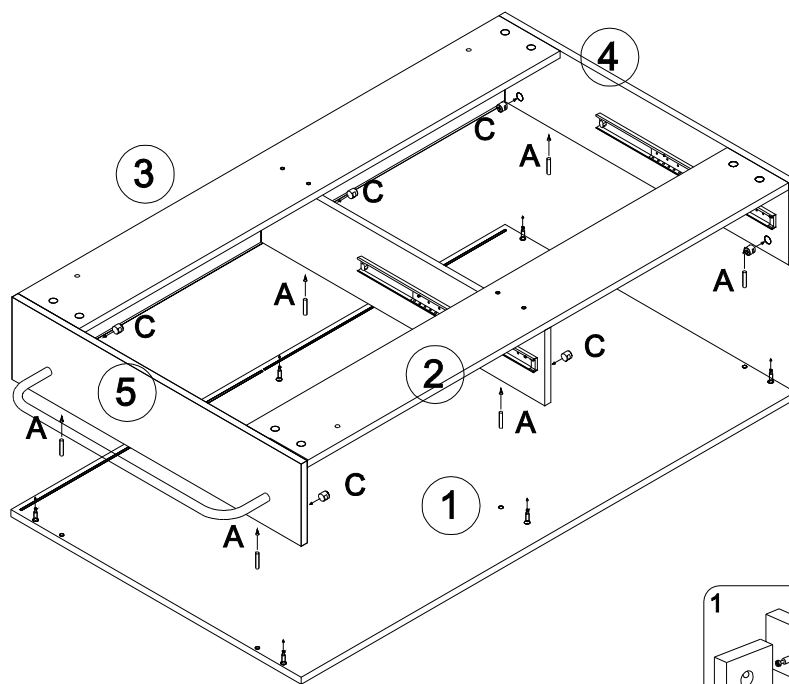

Step 6

A x 6	C x 6
	
Ø8x30mm	Ø15x11mm

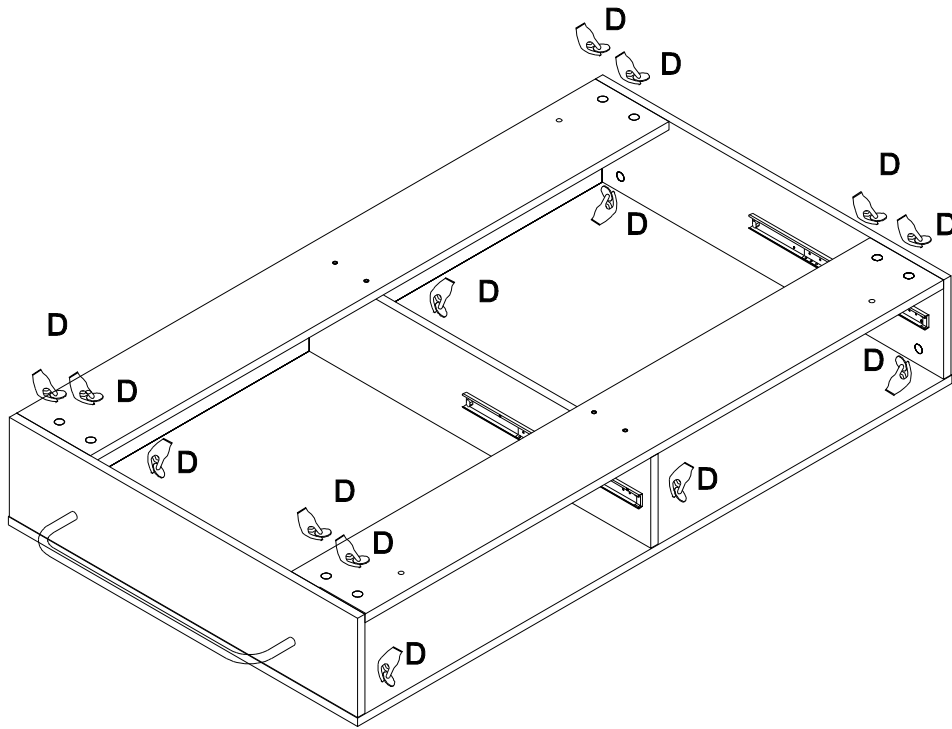

Step 7

D x 14



Step 8

N x 8





O x 8

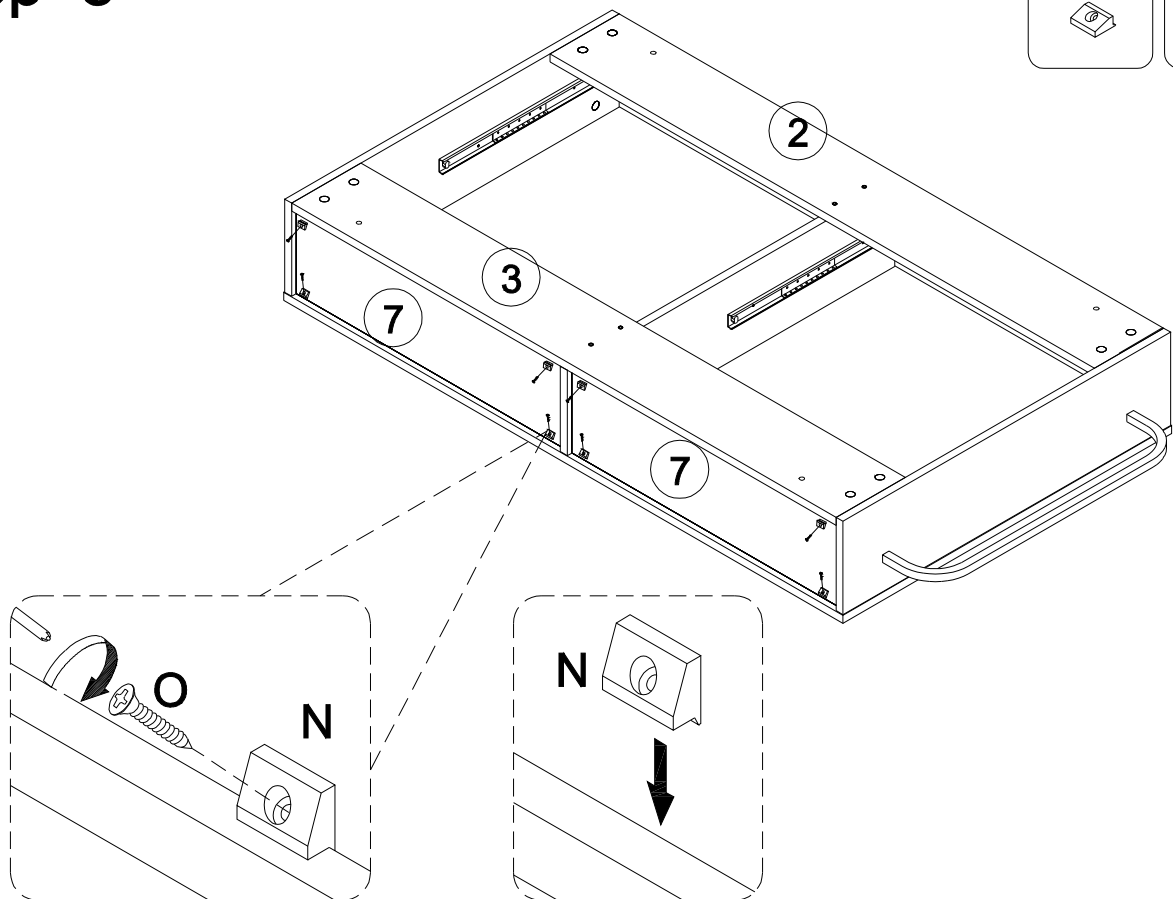

Ø3x17mm





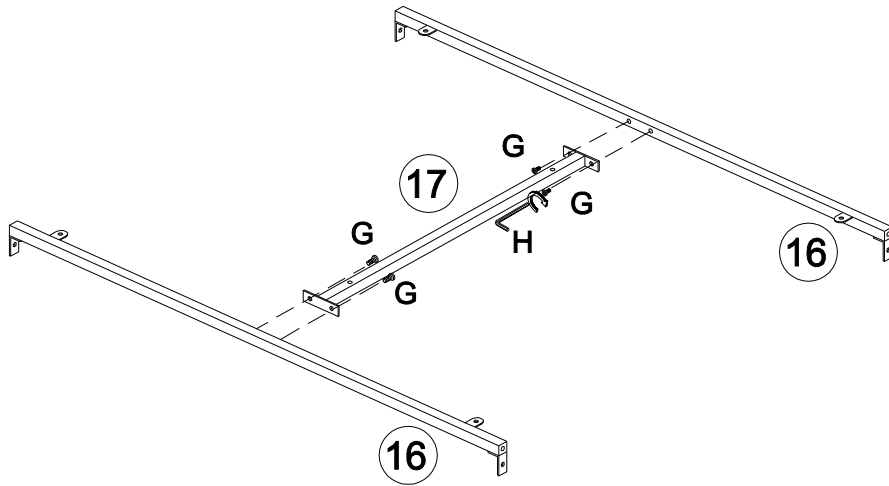

Step 9

G x 4  Ø1/4"x12mm	H x 1  4mm
-------------------------------------------------------------------------------------------------------------------	------------------------------------------------------------------------------------------------------------



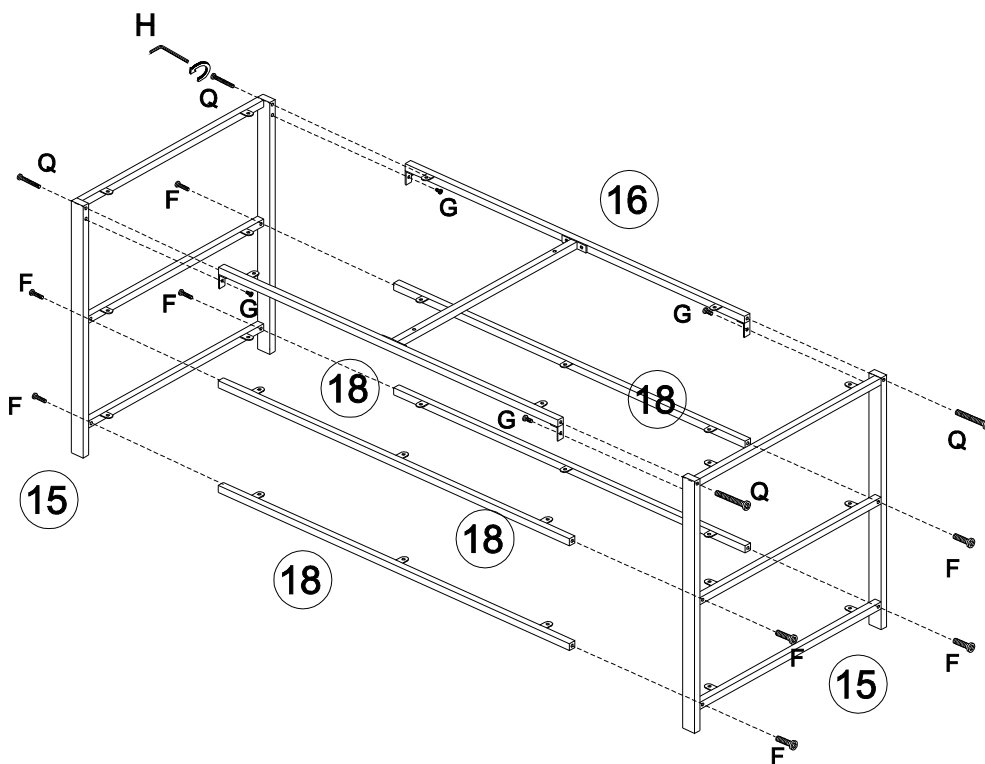

Step 10

F x 8  Ø1/4"x30mm	G x 4  Ø1/4"x12mm	H x 1  4mm	Q x 4  Ø1/4"x57mm
---------------------------------------------------------------------------------------------------------------------	---------------------------------------------------------------------------------------------------------------------	--------------------------------------------------------------------------------------------------------------	---------------------------------------------------------------------------------------------------------------------



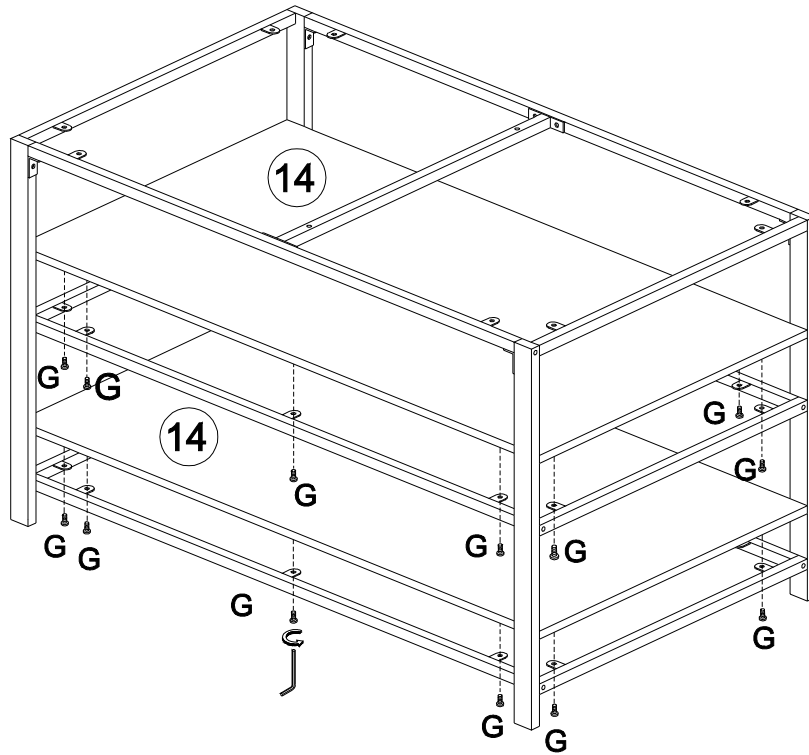

Step 11

G x 20  Ø1/4"x12mm	H x 1  4mm
--------------------------------------------------------------------------------------------------------------------	------------------------------------------------------------------------------------------------------------



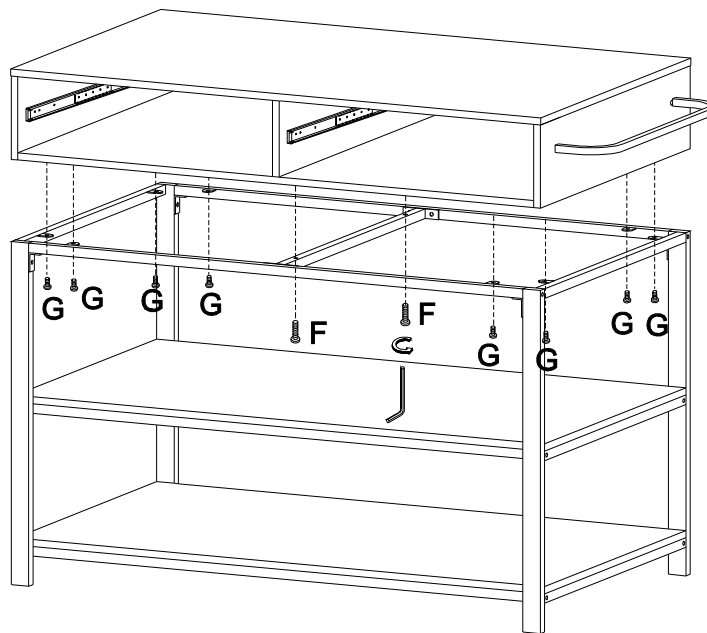

Step 12

F x 2  Ø1/4"x30mm	G x 8  Ø1/4"x12mm	H x 1  4mm
---------------------------------------------------------------------------------------------------------------------	---------------------------------------------------------------------------------------------------------------------	--------------------------------------------------------------------------------------------------------------



Step 13

B x 10  Ø6x35mm	J x 2 	P x 4  Ø4x18mm
-----------------------------------------------------------------------------------------------------------------	-----------------------------------------------------------------------------------------------------	----------------------------------------------------------------------------------------------------------------

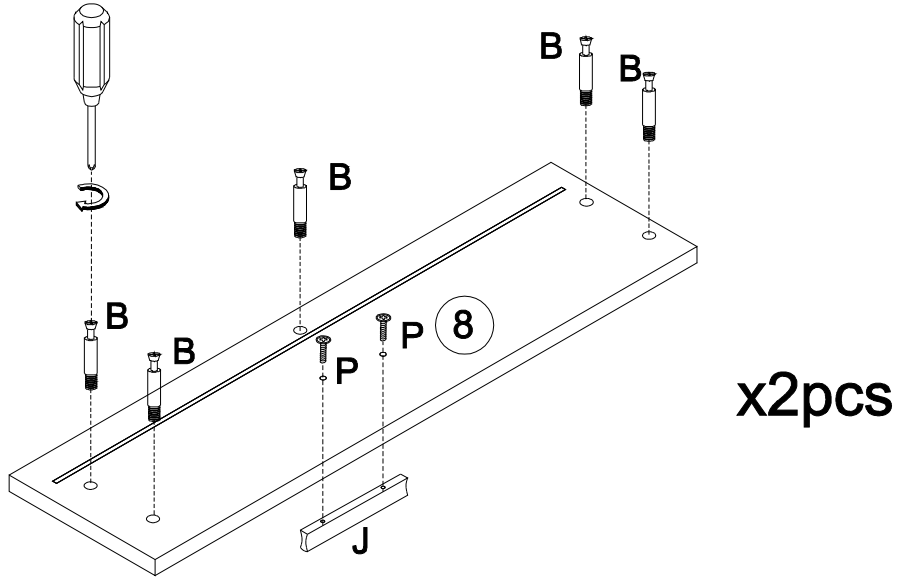

Step 14

K x 8  Ø4x30mm

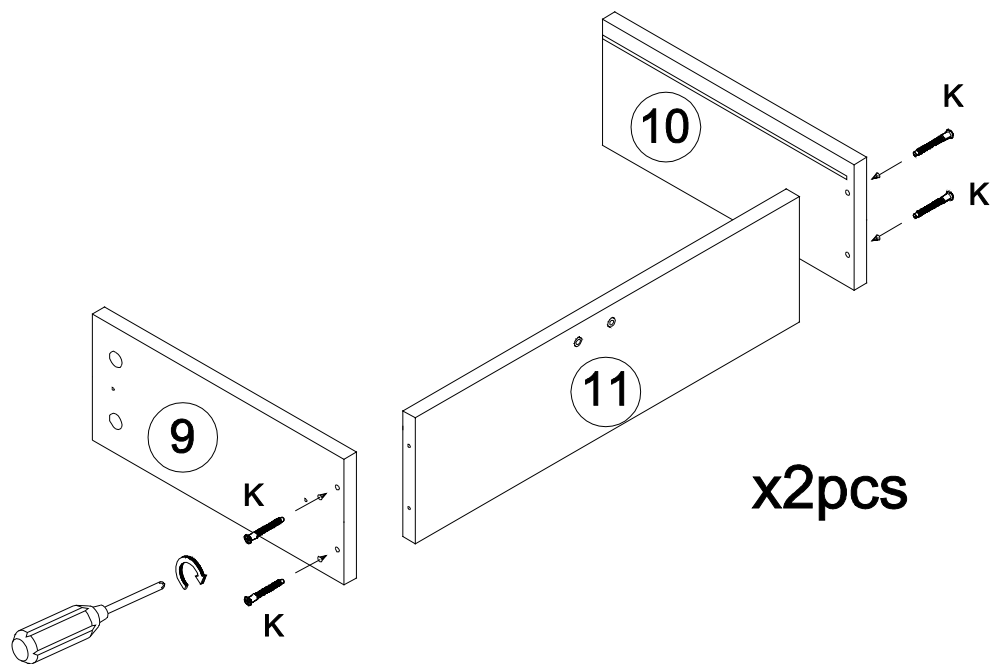

Step 15

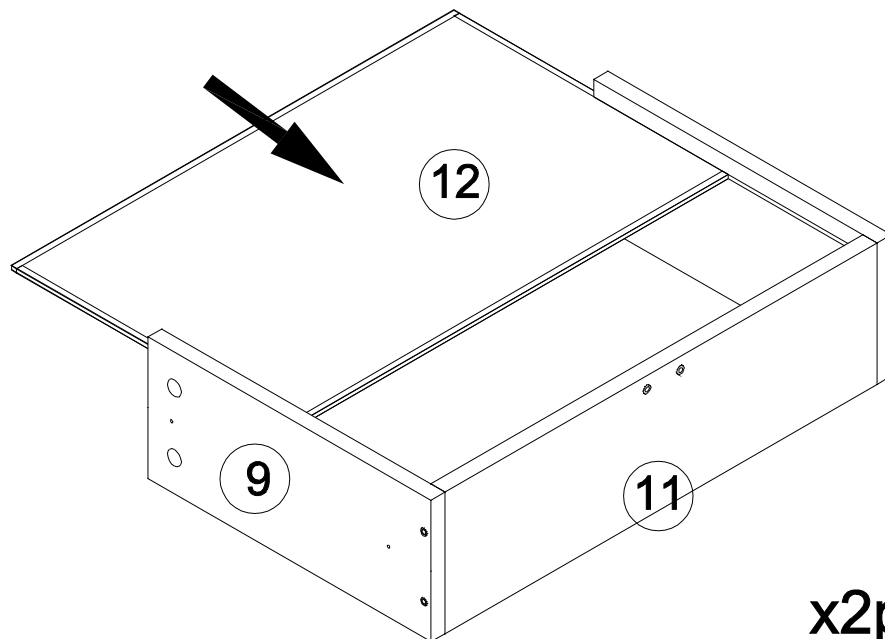

Step 16

K x 4

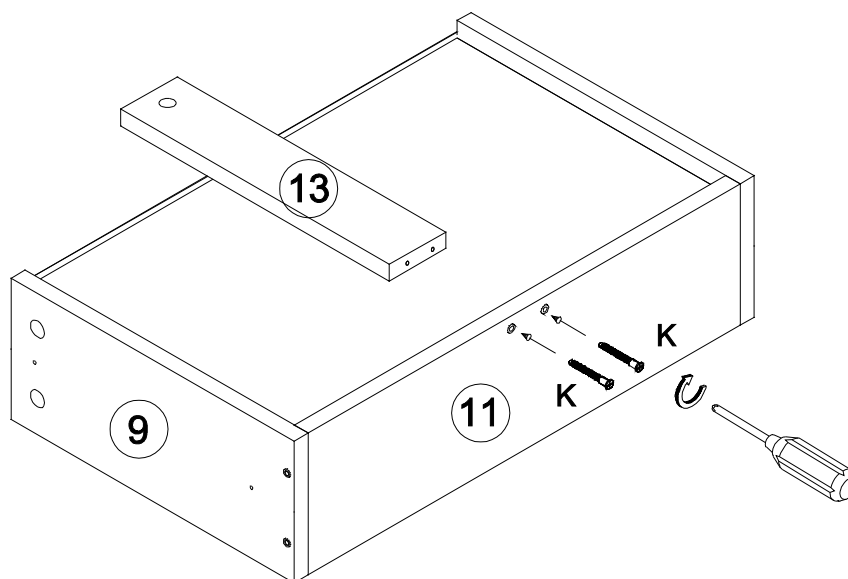

Step 17

C x 10
Ø15x11mm

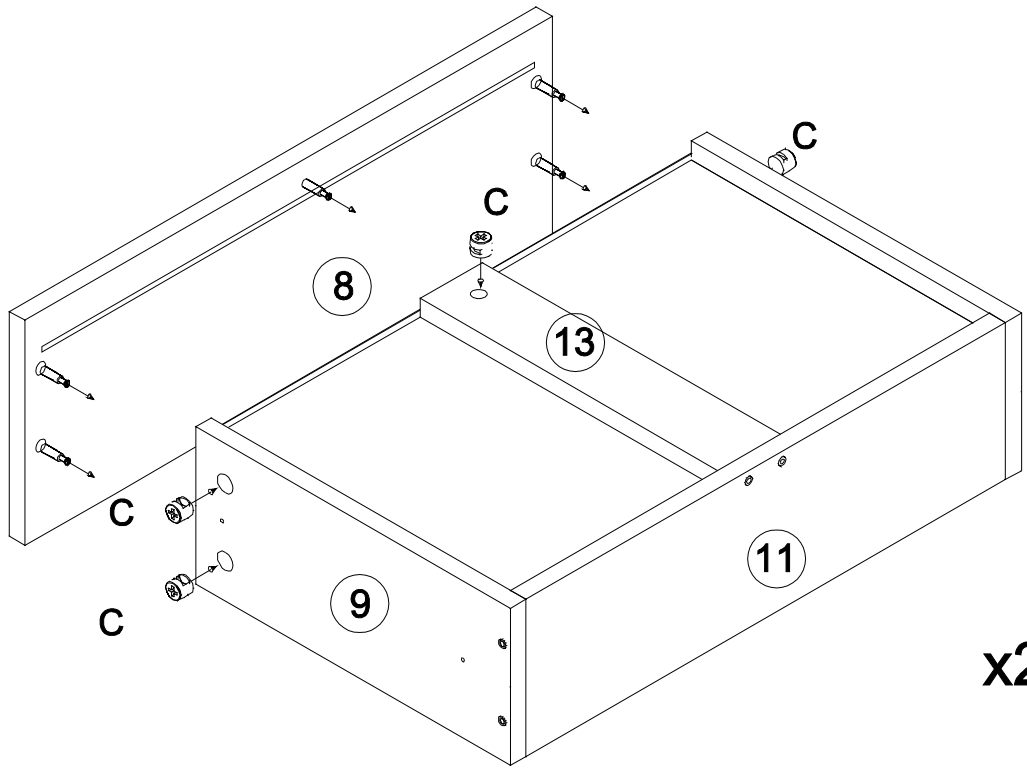

x2pcs

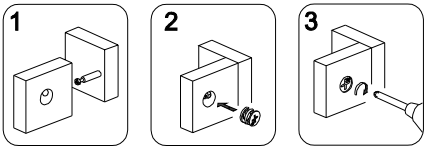

Step 18

M x 2
L x 8
Ø3.5x14mm

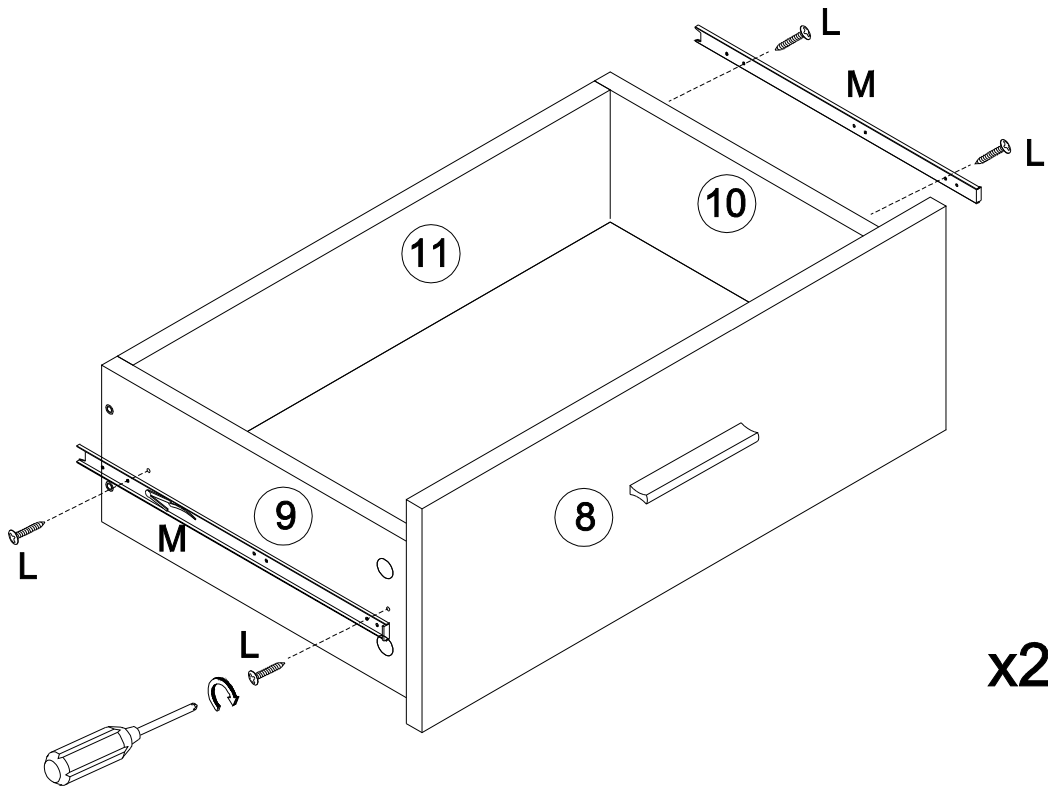

x2pcs

Step 19

D x 10
○

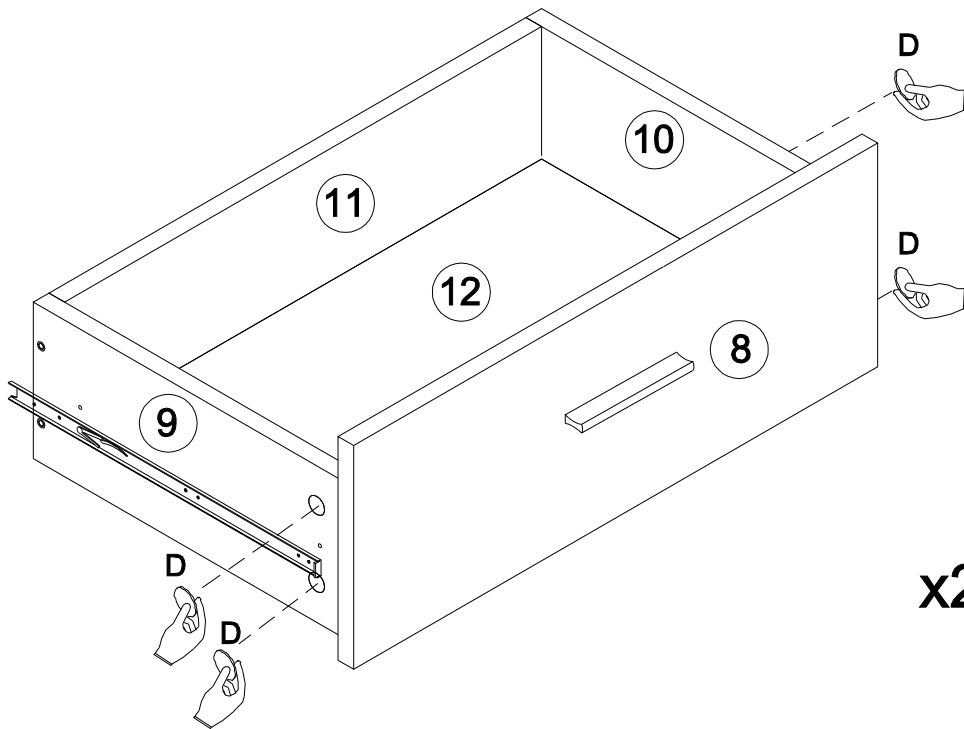

Step 20

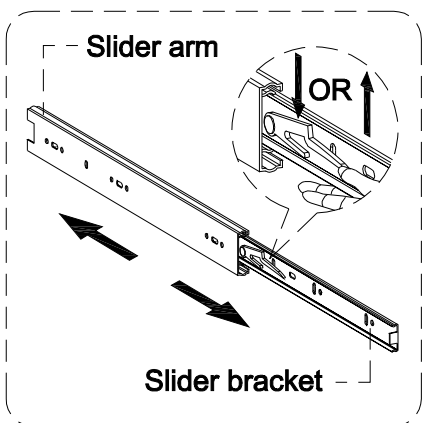
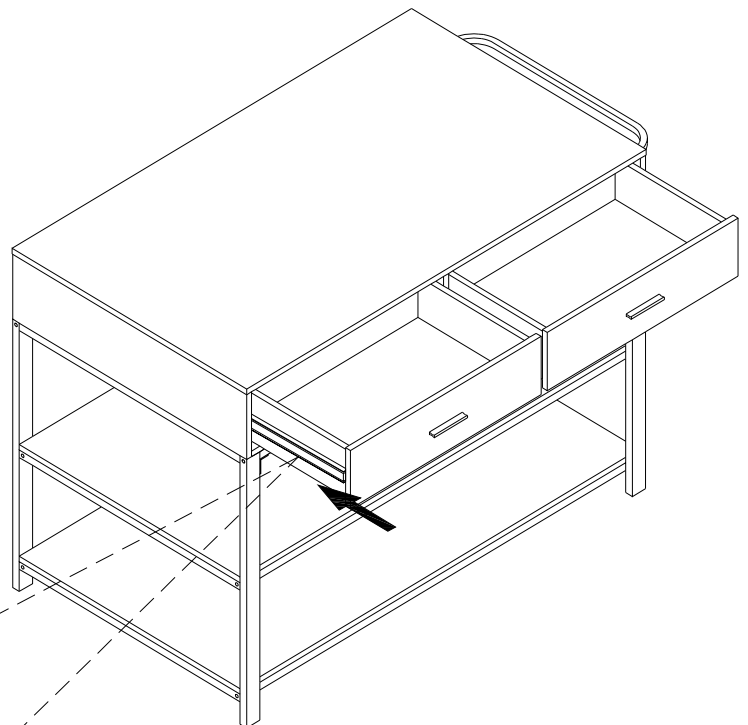

Step 21

