







ITEM NO. 92517 OFFICE CHAIR

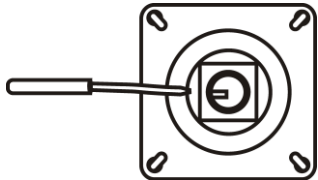

ASSEMBLY INSTRUCTIONS

1	2	3
 <p>GAS LIFT 1PC</p>	 <p>BASE 1PC</p>	 <p>CASTER 5PCS</p>
4	5	
 <p>SEAT 1PC</p>	 <p>BRACKET W/HANDLE 1PC</p>	
A	B	
 <p>BOLT 4PCS</p>	 <p>WRENCH 1PC</p>	

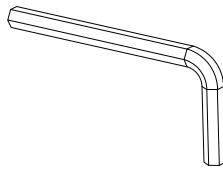
STEP 1

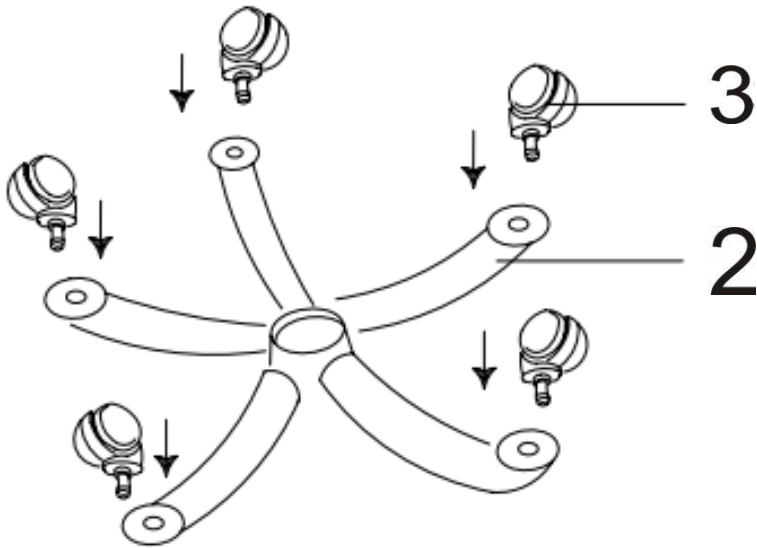

*Please put all parts on a soft surface to prevent scratches.

Insert caster (3) into base (2) carefully as shown.

STEP 2

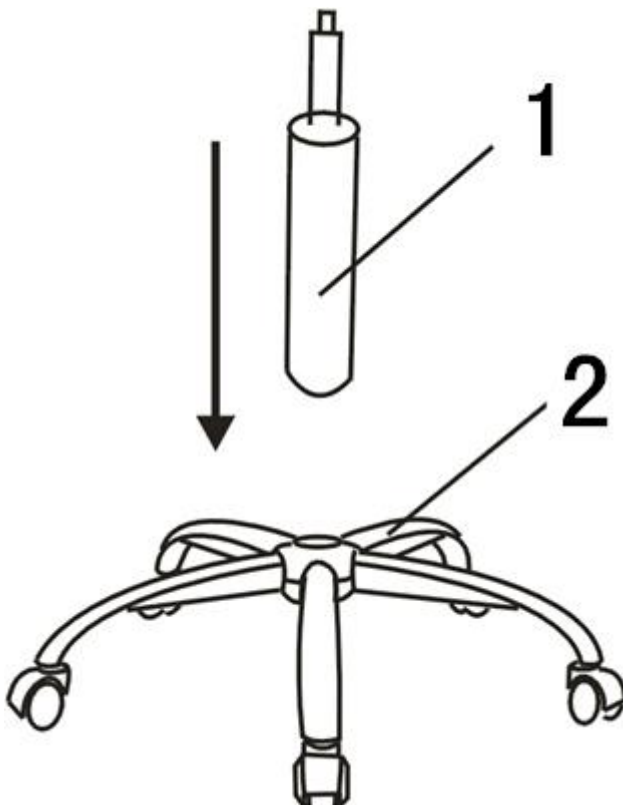

Insert gas lift (1) into base (2) carefully as shown.

STEP 3

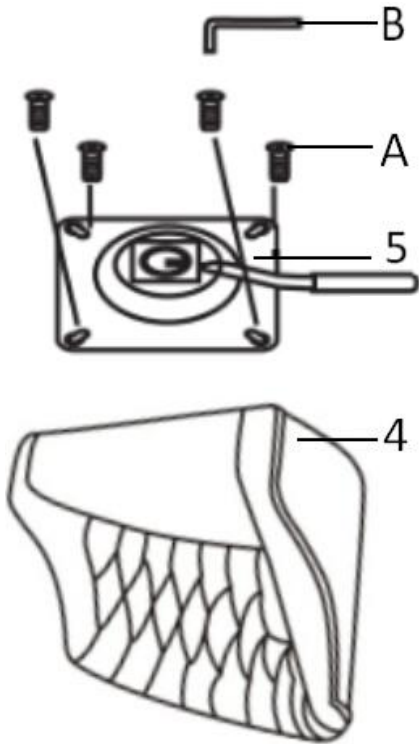

Attach bracket w/handle (5) to seat (4) by using bolt (A) and wrench (B) as shown.

Tighten all bolts firmly!

STEP 4

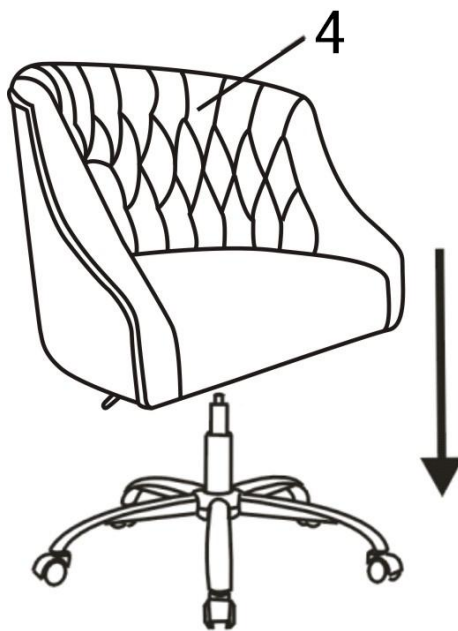

Insert gas lift (1) into seat (4) by applying moderate downwards force to the seat (4) in order to secure it to the base as shown.

Your office chair is completed.