

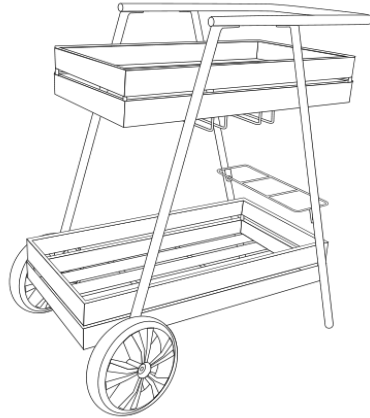

Assembly Instructions



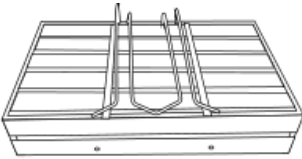
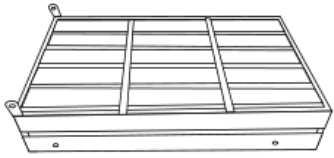
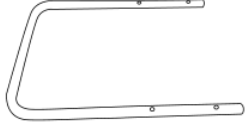

Caution: You must read this before you proceed

Bar Cart









Parts List

Label	Picture	Description	QTY
A		Top Shelf	1
B		Bottom Shelf	1
C		Handrail	1
D		Middle Rack	1
E		Front Right Wheel Support	1

F		Front Left Wheel Support	1
G		Rear Left Support	1
H		Rear Right Support	1
I		Wheel	2

Hardware

Label	Picture	Description	QTY
①		Bolt(M8*20mm)	9
②		Bolt(M8*15mm)	9
③		Nut	3
④		Washer(M12*25mm)	3
⑤		Washer(M12*30mm)	3
⑥		Allen Wrench	1
⑦		Allen Wrench	1

Assembly Preparation

Before Beginning Assembly:

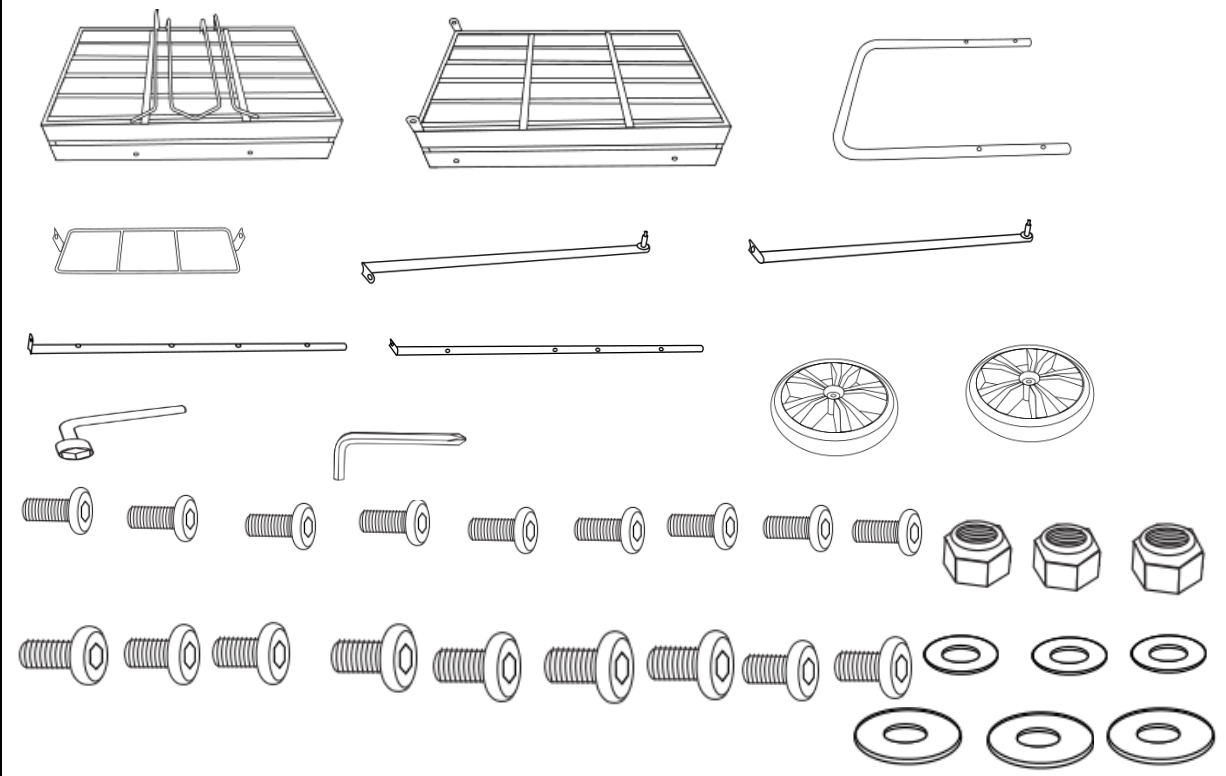

- Read instructions, cover to cover-



- Have 2 adults on hand for assembly-



- Do not assemble on flooring or carpet-



- Assemble on a clean non-marring surface (packing foam)-



- Save all packaging until finished-

Assembly Steps

Overview

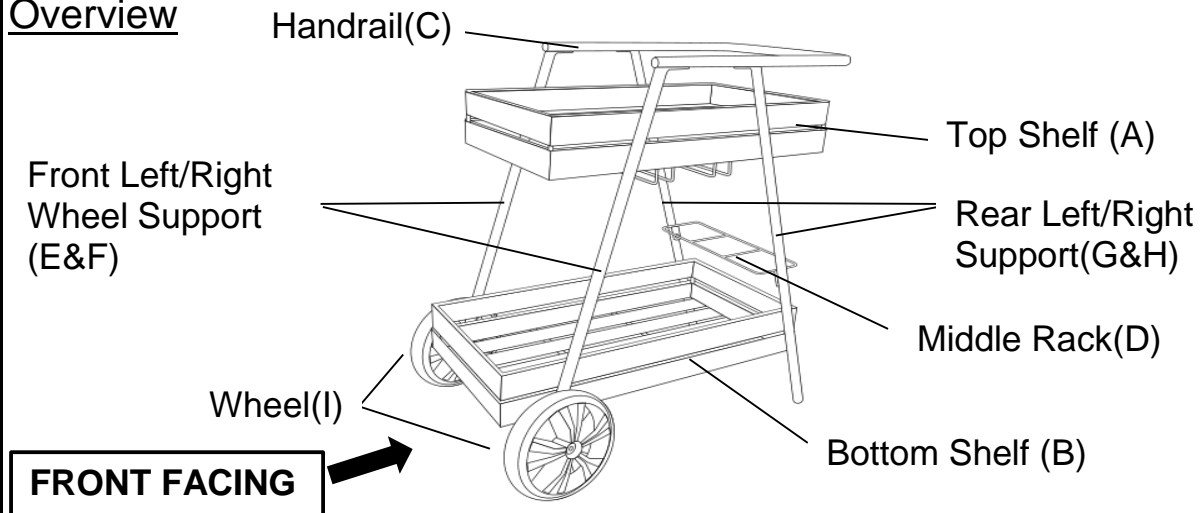

This Bar Cart has multiple parts and may require up to some 30 minutes to assemble. To give you an overview of the Bar Cart parts, the above picture is to help you put the various parts into perspective. Please read through the instructions herebelow to familiarise yourself with the parts and steps before assembly.

Step 1

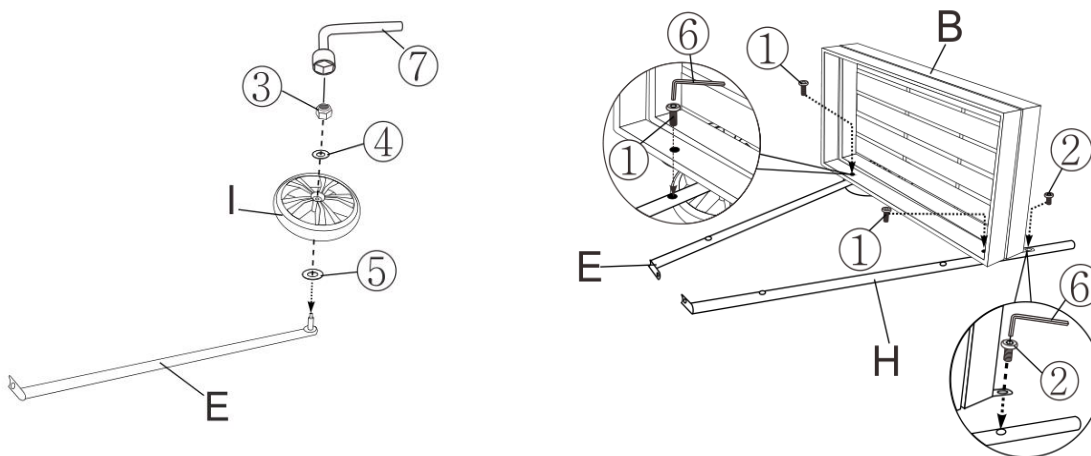

Place the Front Right Wheel Support(E) onto a clean, non-marring surface. Attach the Wheel(I) to the Support(E) using a Washer (④)(⑤) and Nut(③) with the Allen Wrench(⑦), tighten the Nut.

Then, Take out the Rear Right Support(H), Align the Bottom Shelf(B) to the Support(H)and attach it using a Bolt(②) with the Allen Wrench(⑥).

Attach the Bottom Shelf(B) to the Support(E) using a Bolt(①) and the Allen Wrench(⑥).

Do not fully tighten the Bolts at this time.

Step 2

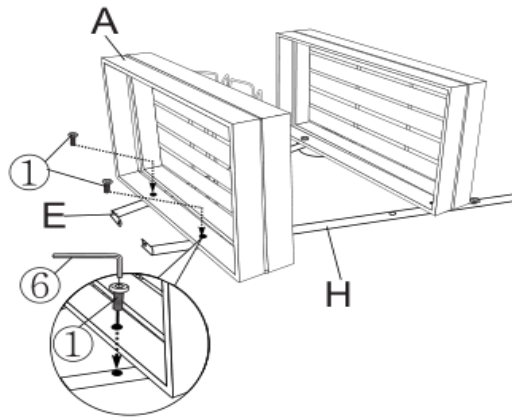

Repeat Step 2 to assemble the Top Shelf (A) using Bolts(①)and the Allen Wrench(⑥).

Do not fully tighten the Bolts at this time.

Step 3

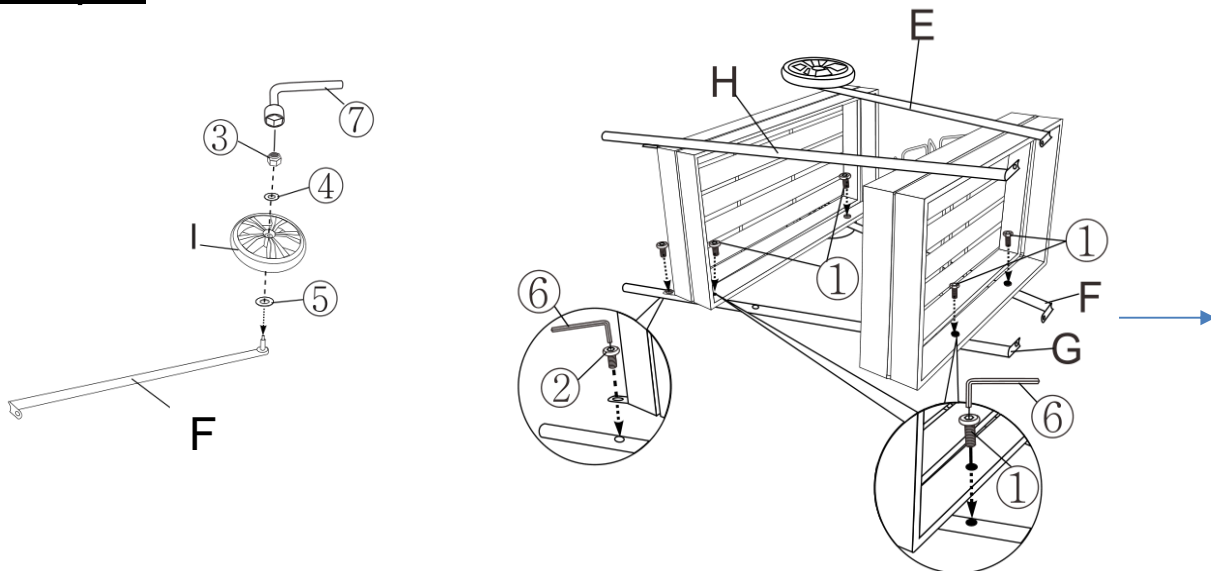

Repeat Step 1 to assemble the Wheel(I) to the Front Left Wheel Support(F). Then, align the Support(F)(G) to the Top and Bottom Shelf(A)(B) as shown above, using Bolts(①)(②)and the Allen Wrench(⑥).

Do not fully tighten the Bolts at this time.

Step 4

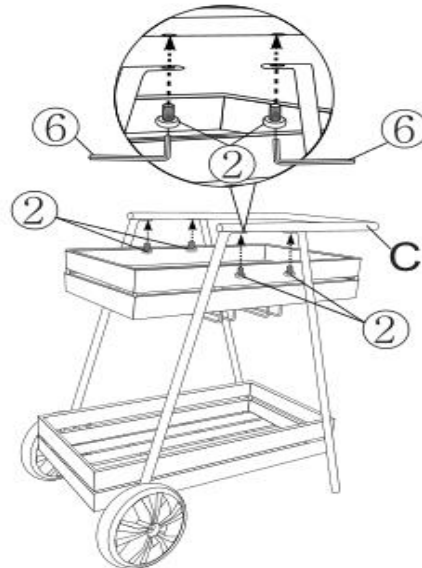

Position the Handrail(C) to the Supports as shown above.
Attach the Handrail(C) to the Supports using Bolts(2) and the Allen Wrench(6).

Do not fully tighten the Bolts at this time.

Step 5

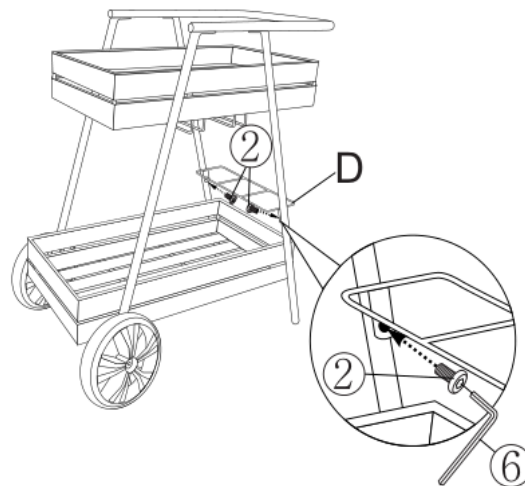

Take out the Middle Rack(D), and attach it using Bolts(2) and the Allen Wrench(6).

Fully and securely tighten all Bolts.

Step 6

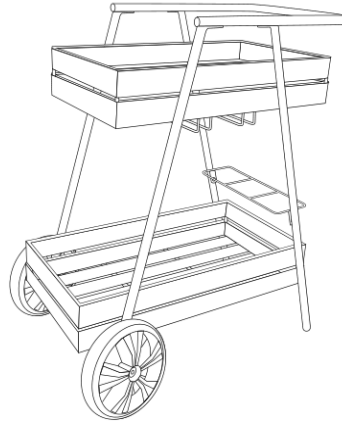

Your Bar Cart is ready for use.

This Bar Cart can only be used on a flat and level surface.

Care & Maintenance



- Do not put hot items directly on furniture surface.



- Do not clean furniture with harsh cleansers or polish



- To obtain the longest lifespan of your outdoor products, minimizing exposure to direct sunlight is recommended.



- Children should not climb or jump on the furniture.



- Do not write on furniture without a padded barrier to protect the surface.



- To obtain the longest lifespan of your outdoor products, avoid extended and lengthy exposure to rain, snow, and direct sunshine. Whenever possible cover the product and /or place under patio or awnings.



- Not for commercial use. For residential use only.



- Stains may be removed with mild soap solution and damp cloth.



- Dust and pick-up spills using a clean, non-colored, lint-free cloth.